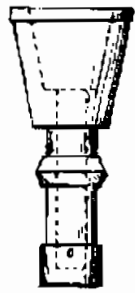

Fig. 1.



Tipi di bombarde primitive.

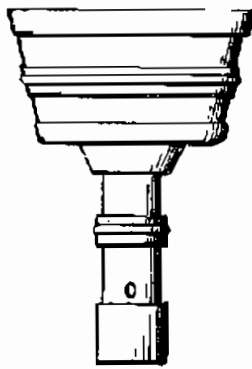
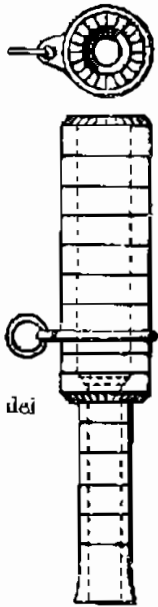

Fig. 2. — Letto di bombarda

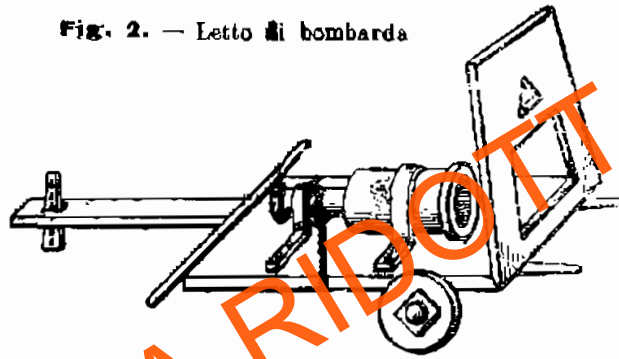

Fig. 3. — Bombarde a retroscice con letto inclinabile

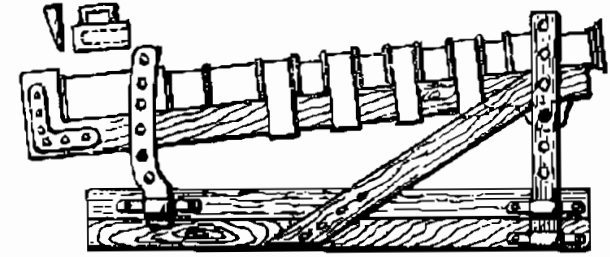

Fig. 4. — Bombarda del secolo XV.



Fig. 5. — Letto a ruote del secolo XV.

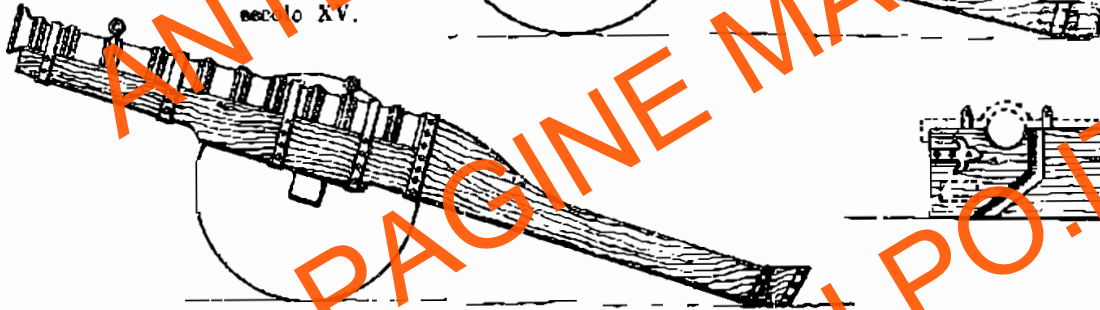

Fig. 6. — Letto a ruote con orecchione.

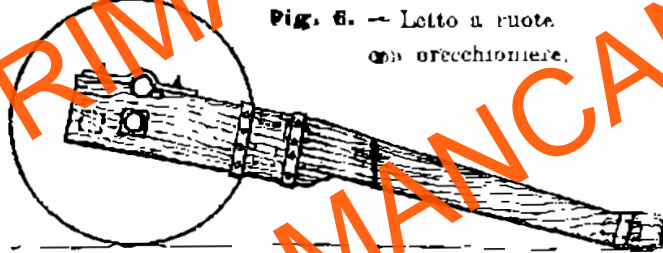

Fig. 7. — Letto per mortaio.

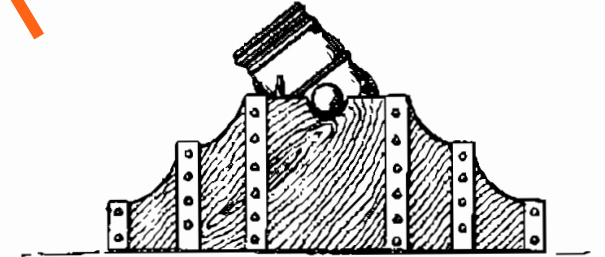
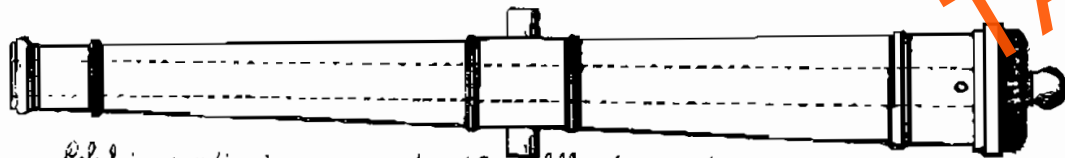

Fig. 8. — Letto per galera o da piazza



Fig. 9. — Artiglierie del secolo XVII.



Colubrina ordinaria comune da 40 libbre (130 mm.) - sequita -

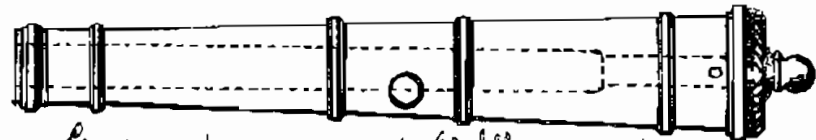

Cannone ordinario comune da 60 libbre - camerato -

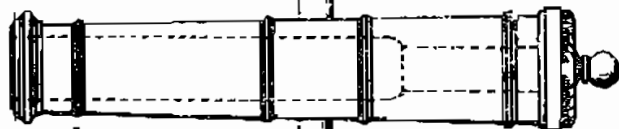

Cannone petriero da 35 libbre



Mortaio

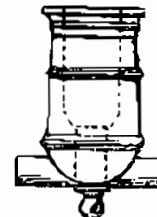

(brabucco)

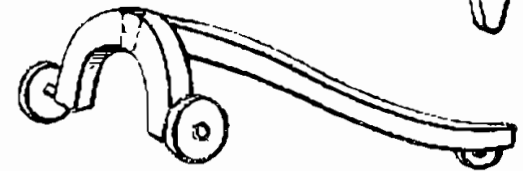
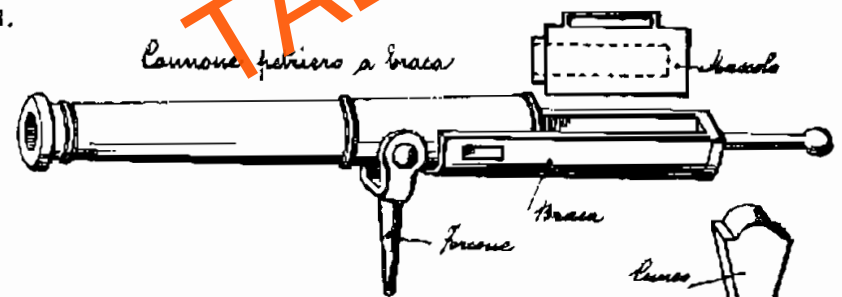

Letto del cannone petriero

ANTEPRIMA RIDOTTA  
PAGINE MANCANTI  
TALPO.IT

Fig. 10.

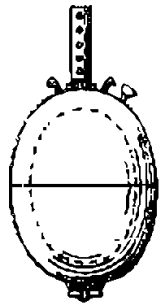

Bomba oblunga.

Fig. 11. —

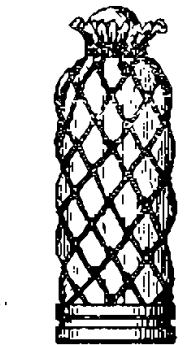

Coiello a miraflexia

Fig. 12. — Squadra del Tartaglia

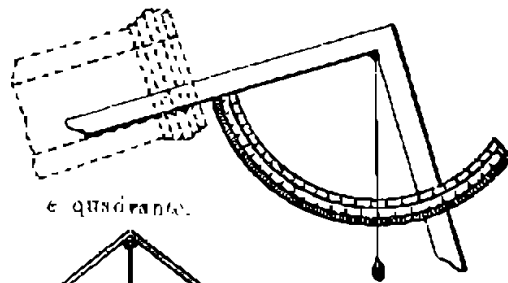

e quadrante.

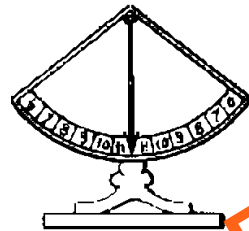
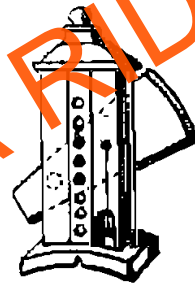

Fig. 13.



Tipo di alzo da secolo XVII



Fig. 14. — Tratto delle artiglierie secolo XVII.

Fig. 18. — Affusto a elisse Gassendi

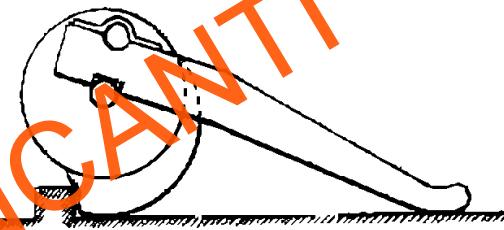
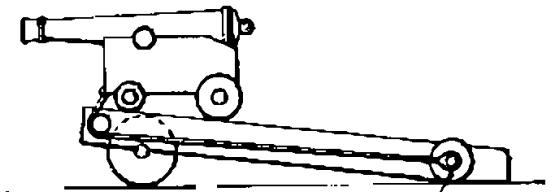

Fig. 19. — Affusto a elisse Redlichkeit



Anticappotto a ruote

Fig. 15. — Artiglierie Gribeauval



Cannoni

Affusto da campagna (Gribeauval)

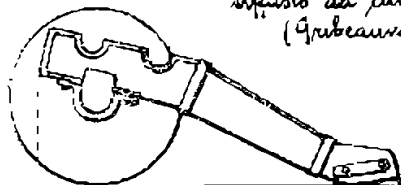

Fig. 17. — Affusto a freccia.

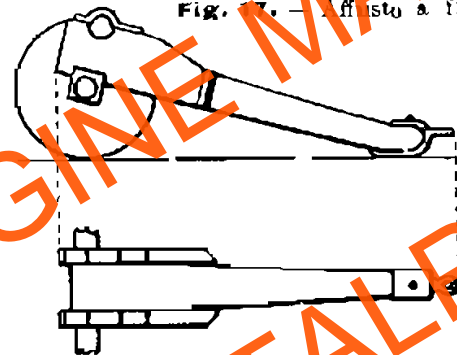

Fig. 20. — Affusto a elisse La Fere

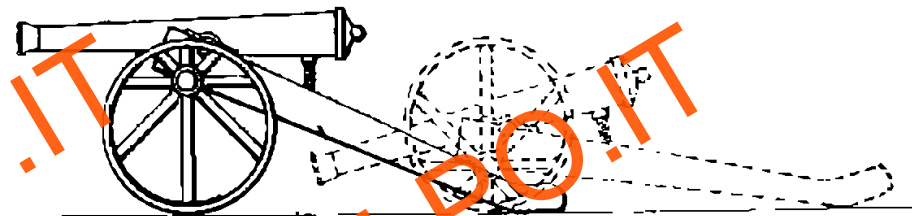

Fig. 16.

Affusto da piazza (Gribeauval)

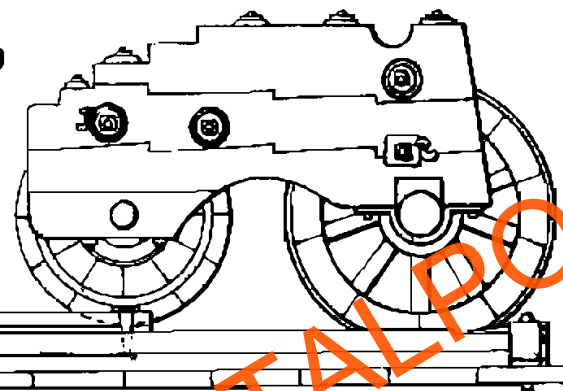
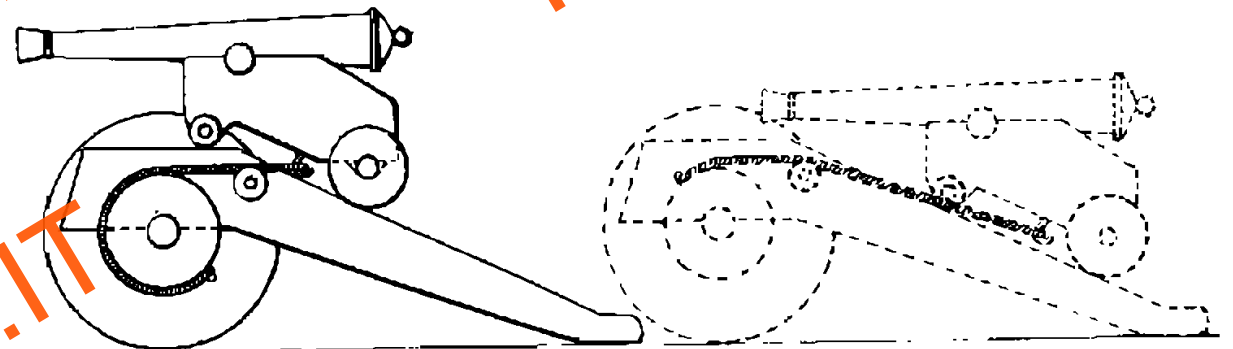
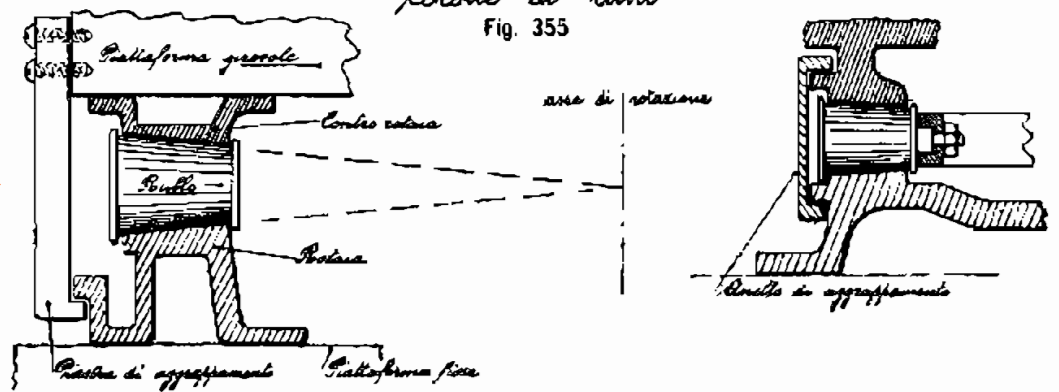
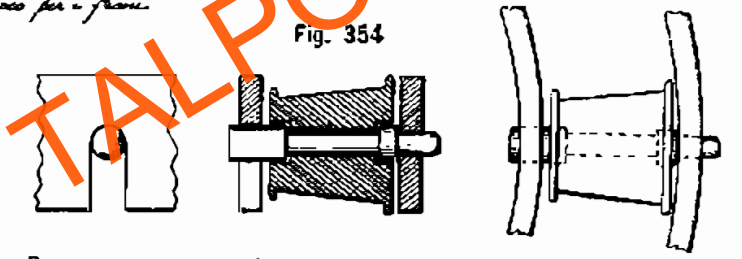
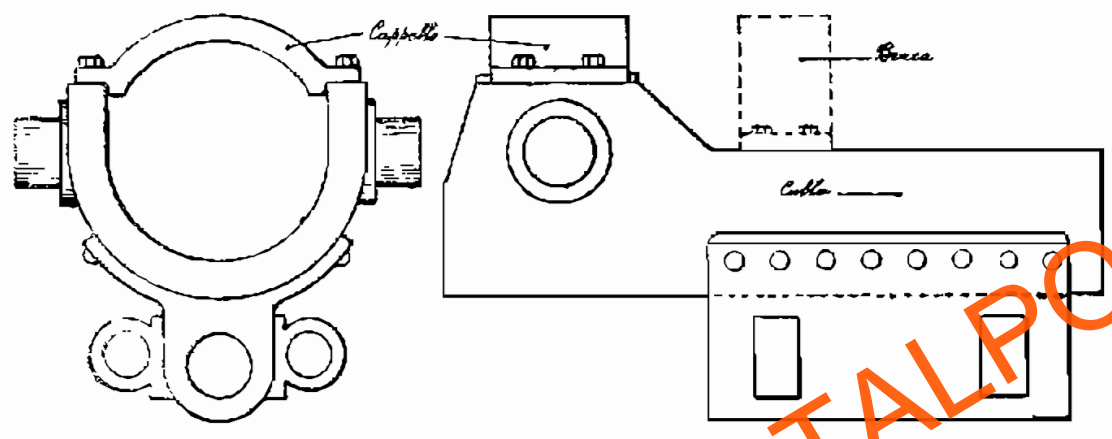
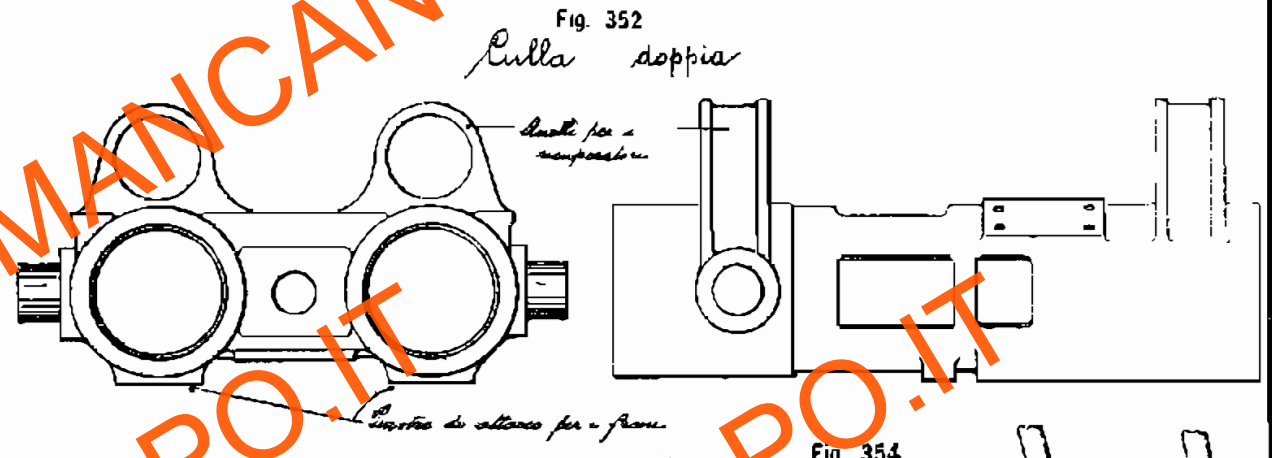
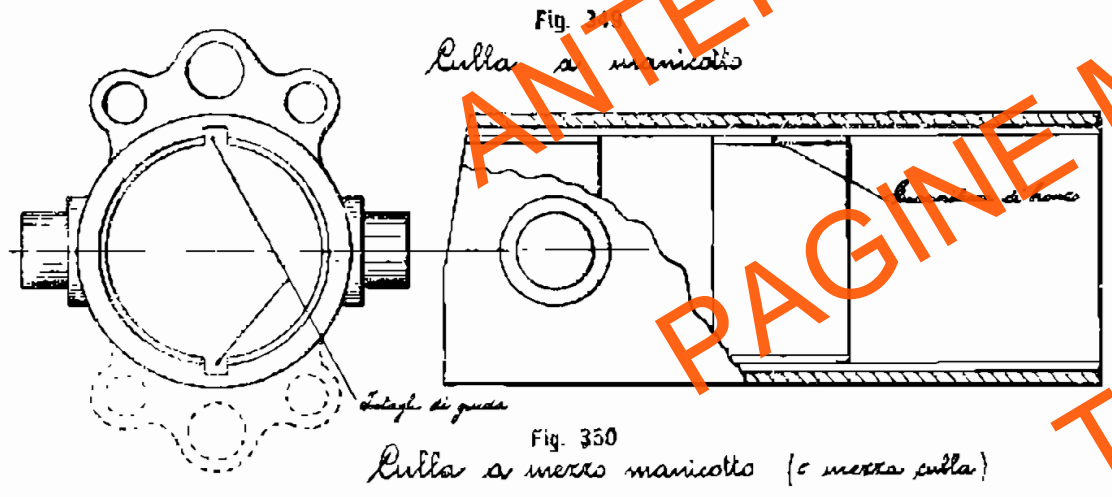
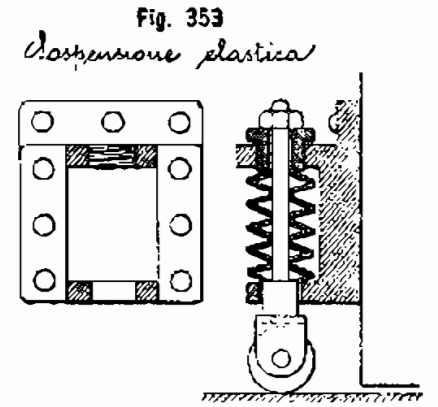
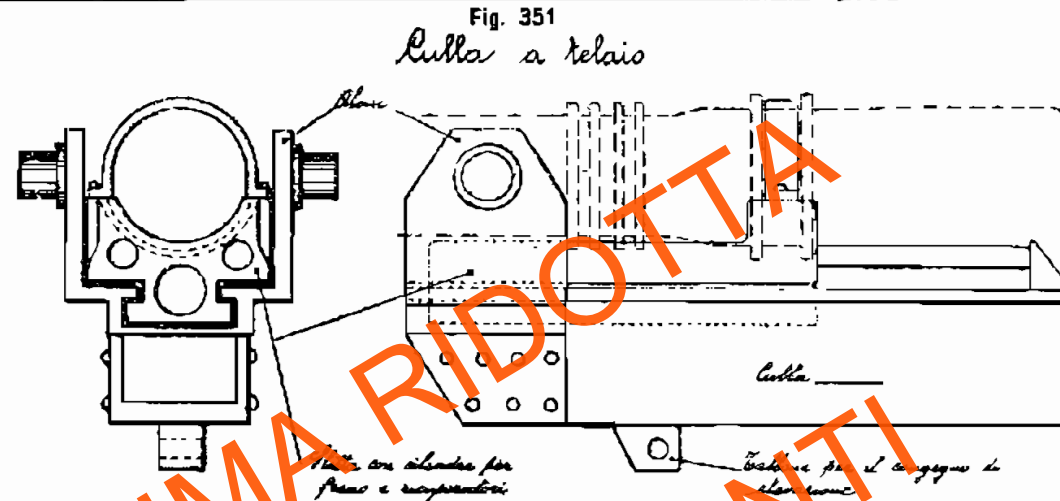
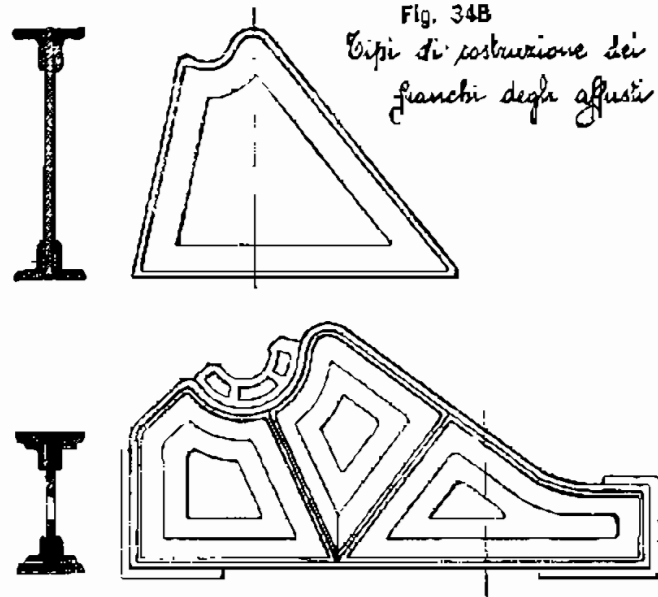

Fig. 21. — Affusto a elisse Chasseloup.



ANTEPRIMA RIDOTTA  
PAGINE MANGANTI  
TALPO.IT



ANTEPRIMA RIDOTTA  
PAGINE MANCANTI  
TALPO.IT

Fig. 360 - Vari tipi di orecchioni e sopra orecchioni.



Fig. 361 - Sospensione elastica degli orecchioni.

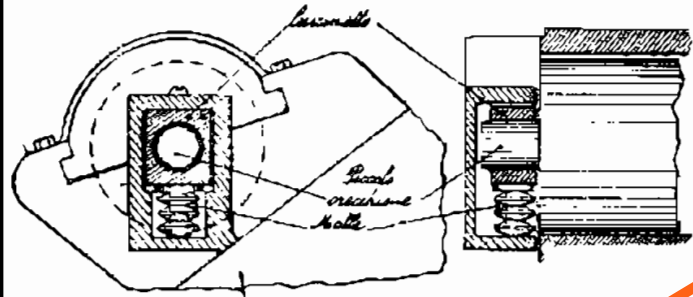

Fig. 362

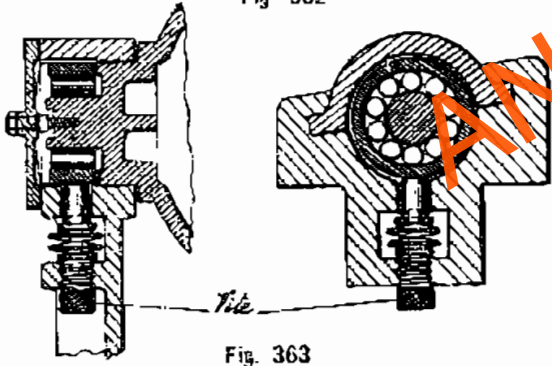
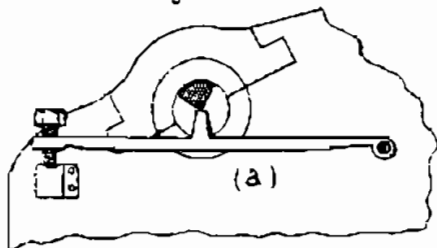

Fig. 363



(b)

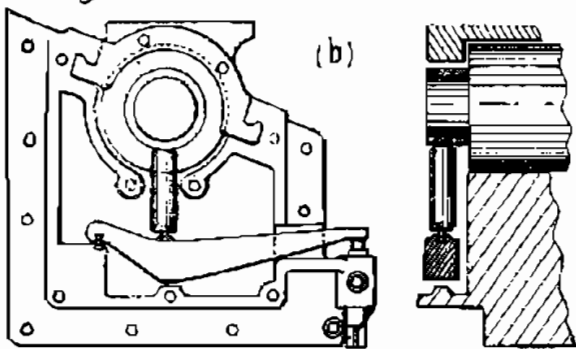

Fig. 365

A vite semplice  
Chiocciola fissa  
(Manovra intermittente)



Fig. 366

A vite semplice  
Chiocciola mobile  
(Manovra intermittente)

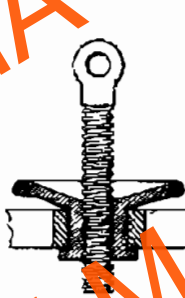

Fig. 367

A vite semplice - Chiocciola mobile  
(Manovra continua)

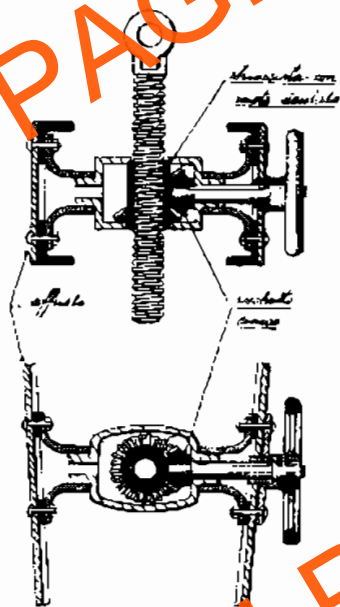

Fig. 367 (b)

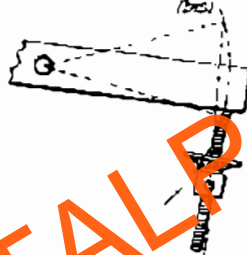

Fig. 368  
A vite semplice - Chiocciola scorrevole  
(Manovra continua)

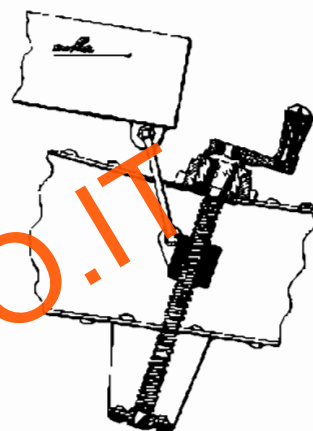

Fig. 364

A cuneo

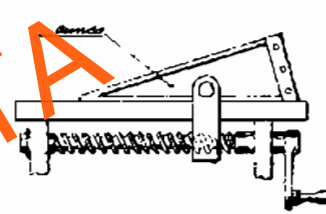

Fig. 369

A vite doppia  
(Manovra intermittente)

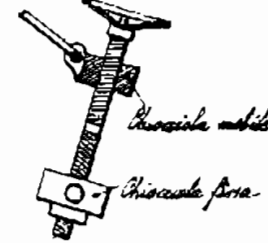

Fig. 370

A vite doppia  
(due vite e una chiocciola)  
(Manovra intermittente)



Fig. 371

A vite maschio e femmina  
(manovra intermittente)  
Chiocciola scillante

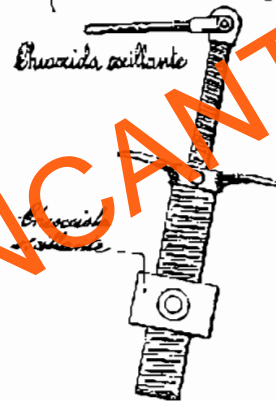

Fig. 372

A vite maschio e femmina  
(manovra continua)

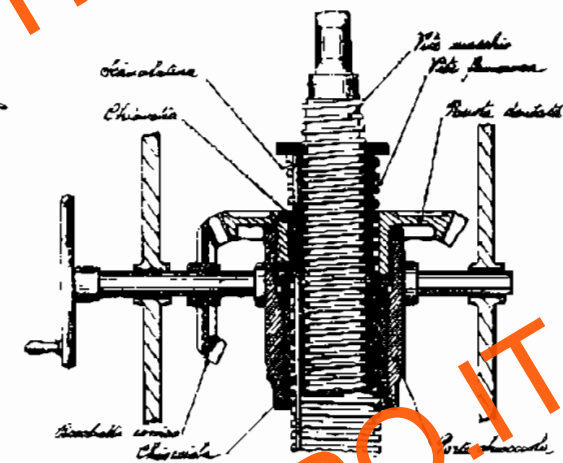

Fig. 373

A vite doppia - Chiocciola scorrevole  
(Manovra continua)

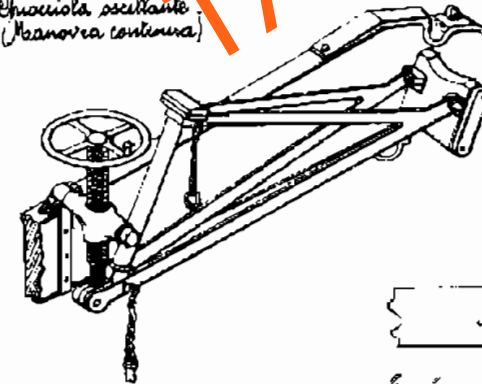
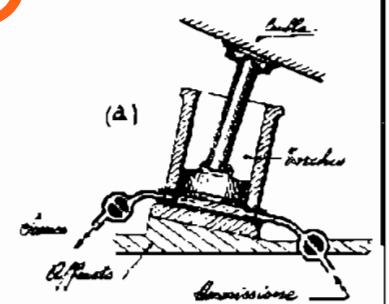

Fig. 381



(b)

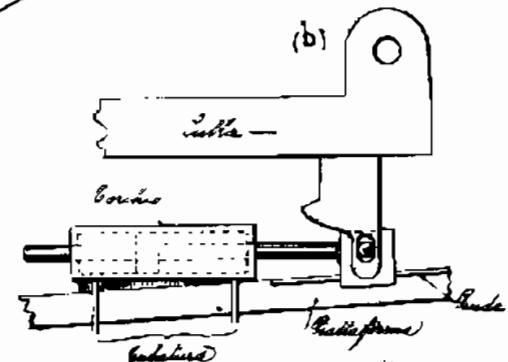

Fig. 414 *Freno ad asta passante, con camera d'aria*



Fig. 417

*A nervature, con freno di ritorno a conto asta, regolabile.*

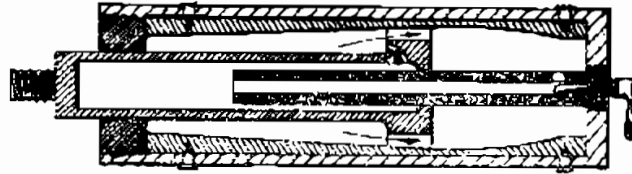

Fig. 415 *Percussore automatico (Cann da 75/137 N. 9A) Schema-*

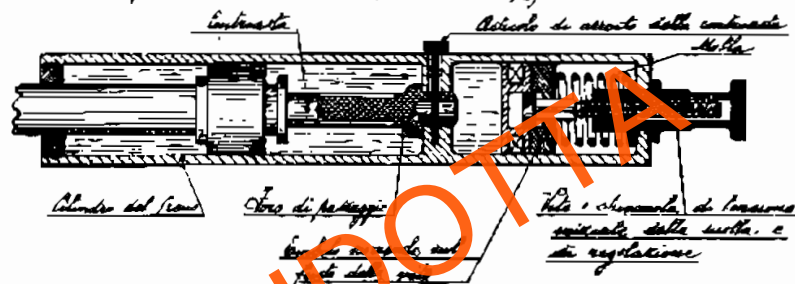

Fig. 416

*- A scanalature, con freno di ritorno a conto asta -*

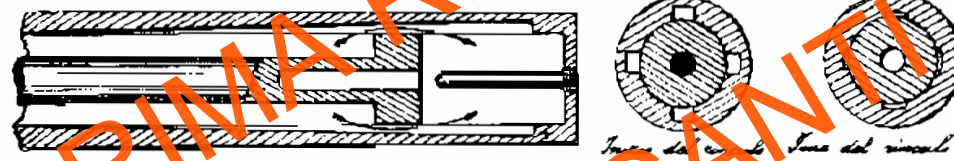

Fig. 422 *- A contropasta con scanalature - Sezione*

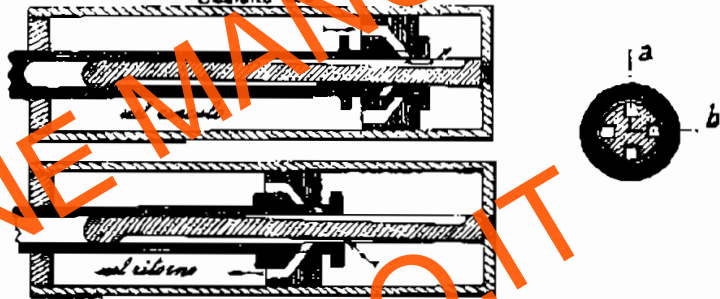
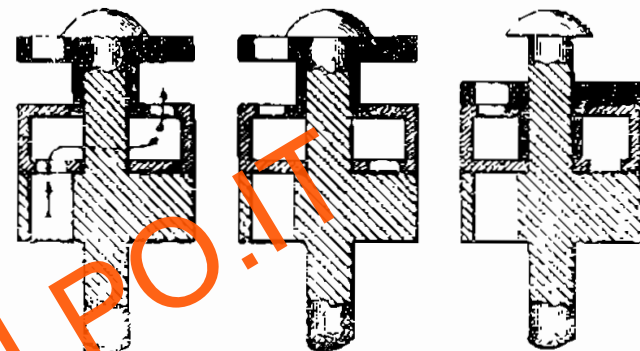
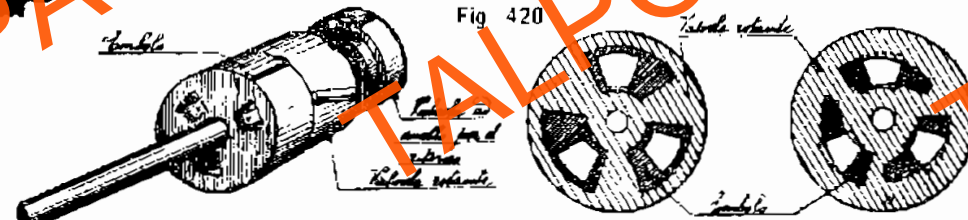

Fig. 420



*al canno del canno al canno del canno al canno del canno*

Fig. 419 *- A valvola rotante - per valvola a farfalla per freno di ritorno -*

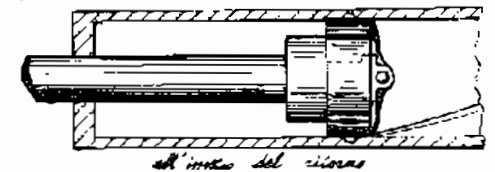
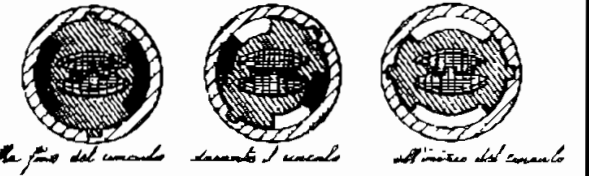
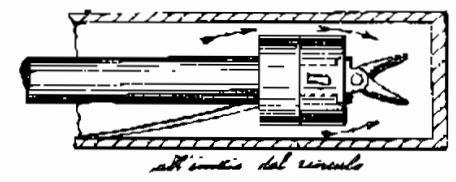
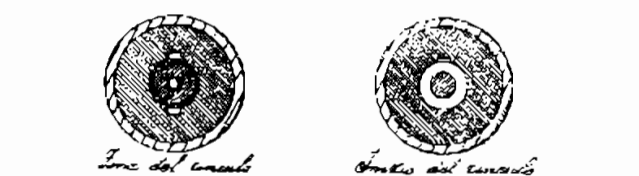
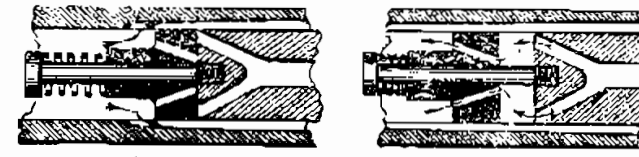

Fig. 421

*- A con valvola rotante anche per freno di ritorno -*



*- Funzionamento della valvola -*



*nel ritorno nel ritorno*

Fig. 418 *- A valvola caricata (con foro per il freno di ritorno) -*

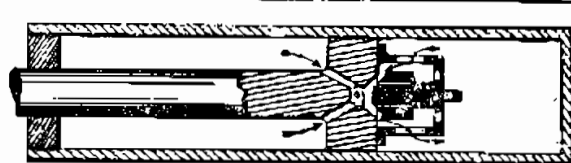

ANTEPRIMA RIDOTTI  
PAGINE MANCANTI  
TALPOIT  
TALPOIT

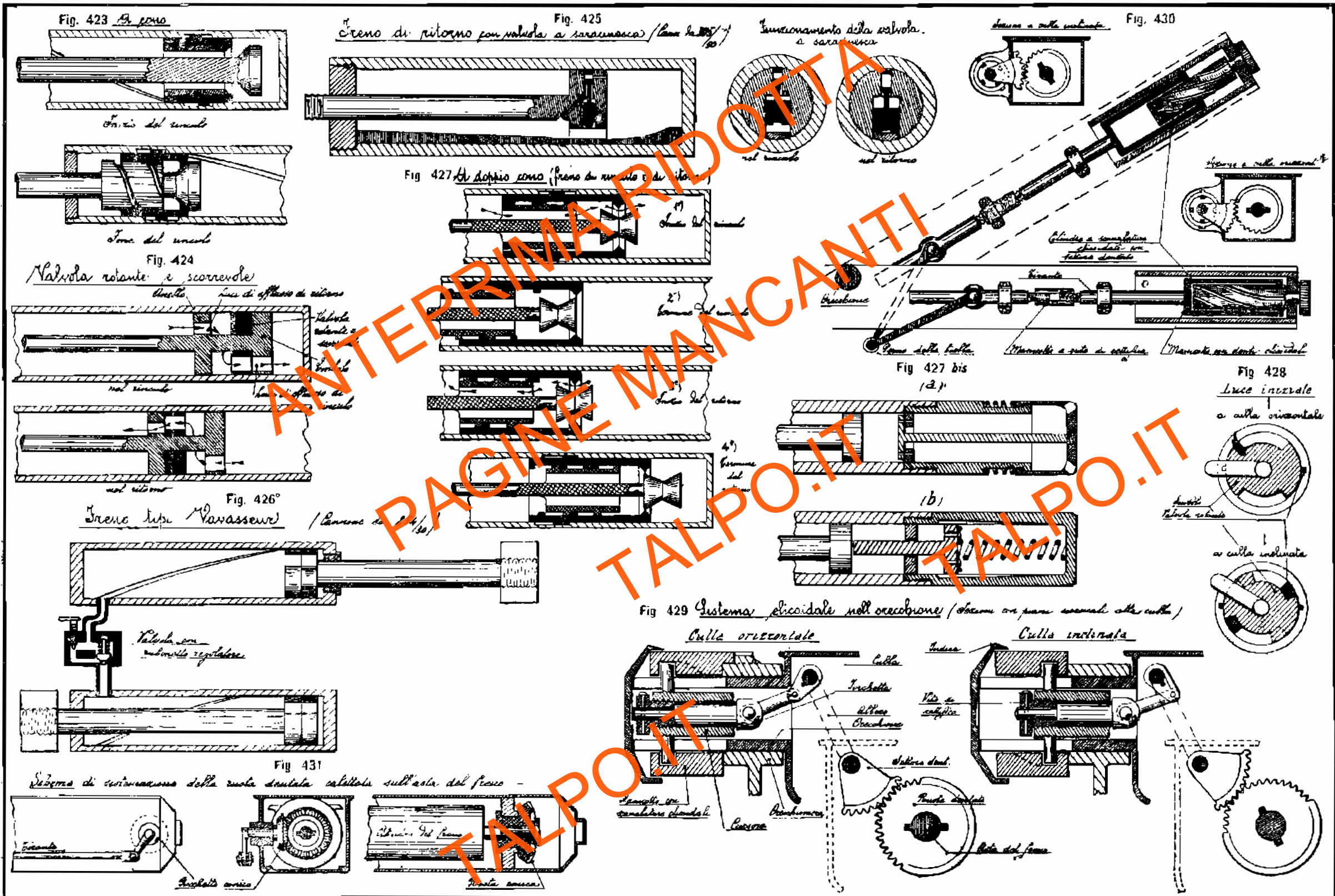

ANTEPRIMA RIDOTTA  
 PAGINE MANCANTI  
 TALPO.IT

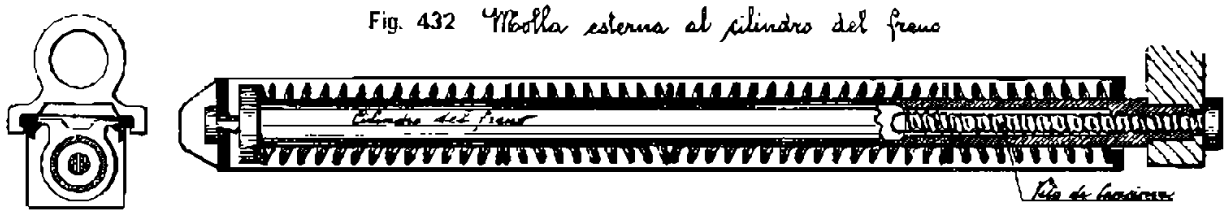

Fig. 432 Molla esterna al cilindro del freno

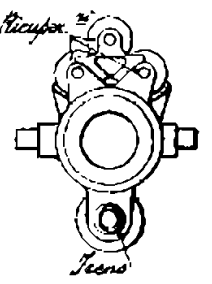

Fig. 433 Sistemazione indipendente dal freno

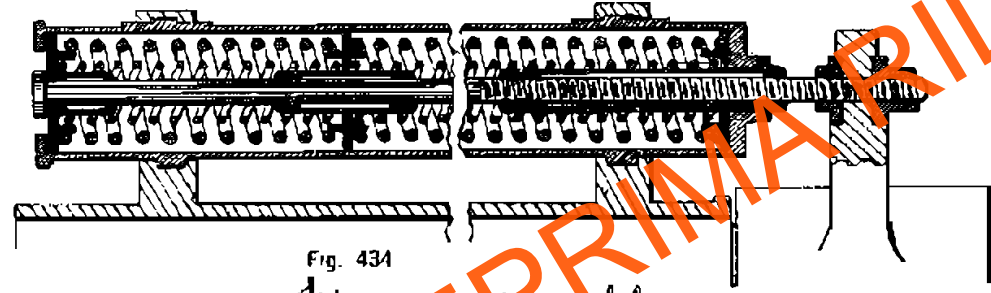

Fig. 434 Sistemazione a pressione al freno



Fig. 435 Molle multiple a telescopio

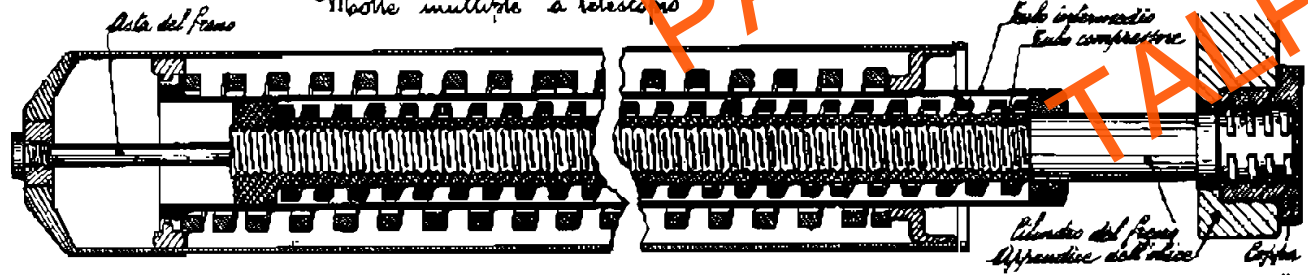

Fig. 442 Vari tipi di sistemazione relativa di freno e recuperatori ad aria

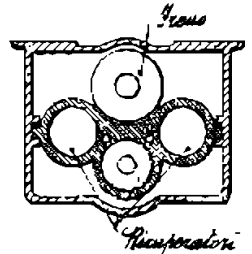

Fig. 443 Recuperatore pneumatico con sistemazione della tenuta d'aria

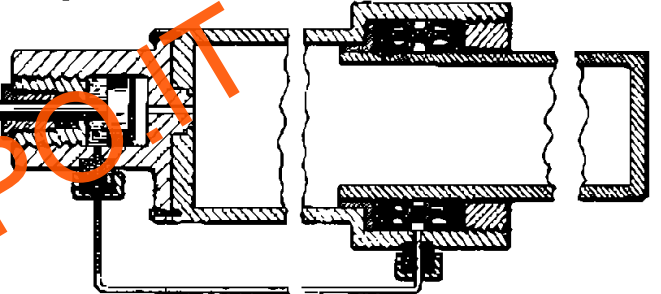
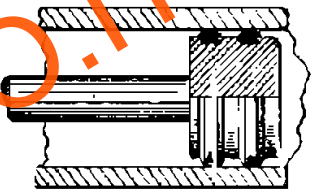
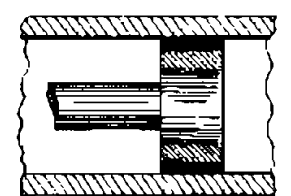

Fig. 444 a) Tamburo con anelli di bronzo



b) Tamburo con bossolo di bronzo



c) Tamburo con coppie di cusce e molla

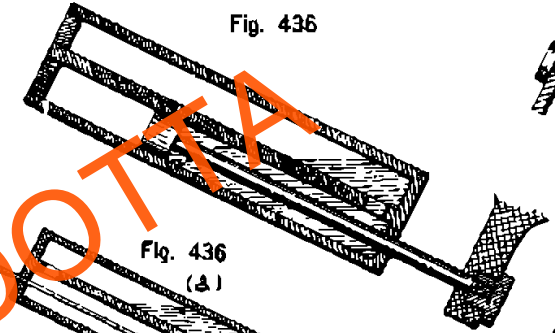
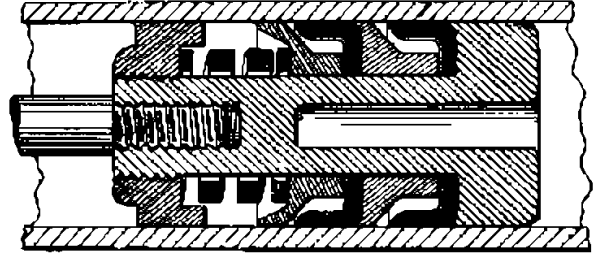

Fig. 436

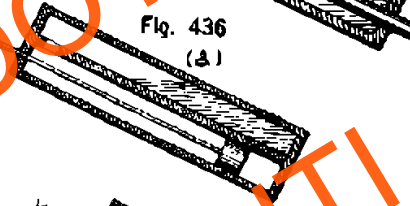

Fig. 436 (a)

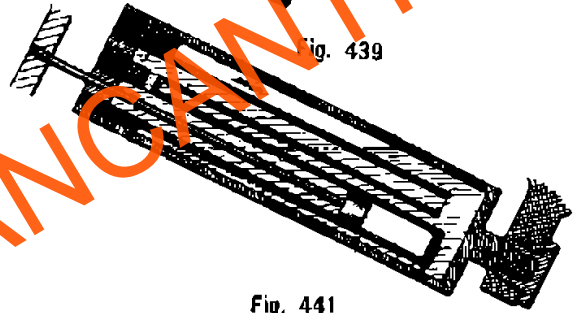

Fig. 439

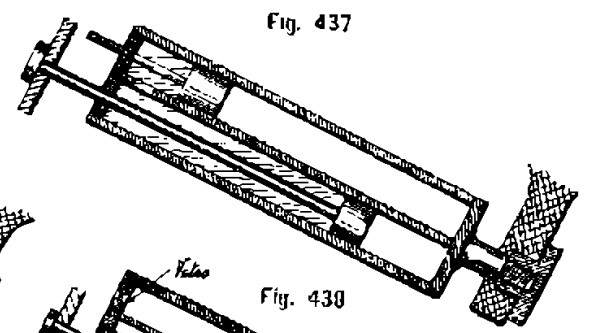

Fig. 437

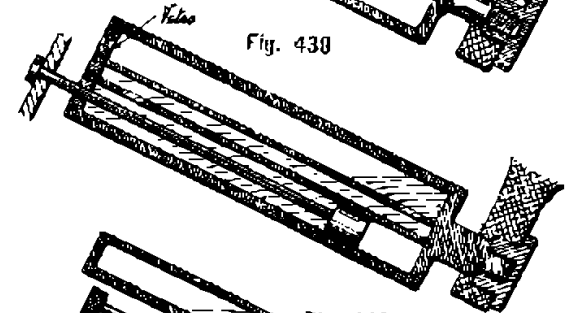

Fig. 438

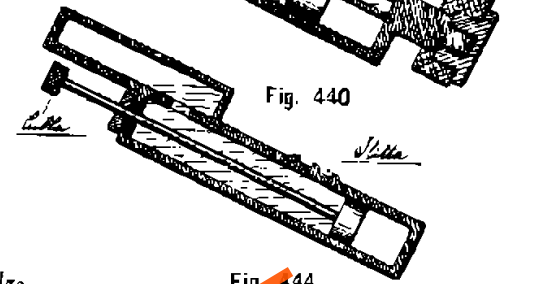

Fig. 440

Fig. 441 Recuperatore con camera d'aria normale al cilindro (L. n. 280/15 Koda)

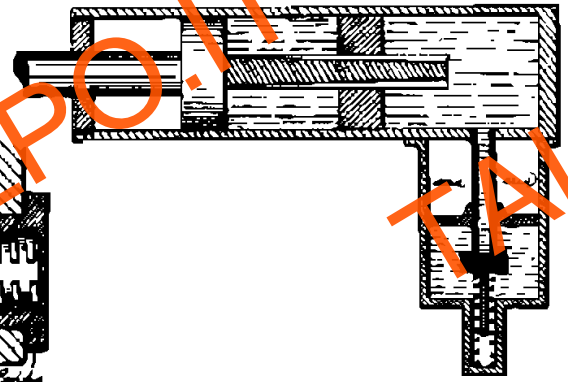

Fig. 444

a) Tambolo pneumatico. Fig. 444

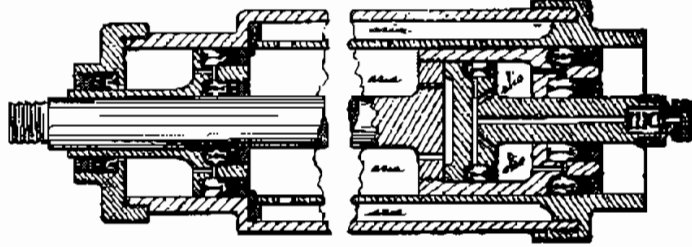

Fig. 446 Freno recuperatore del cannone da 75 Francese

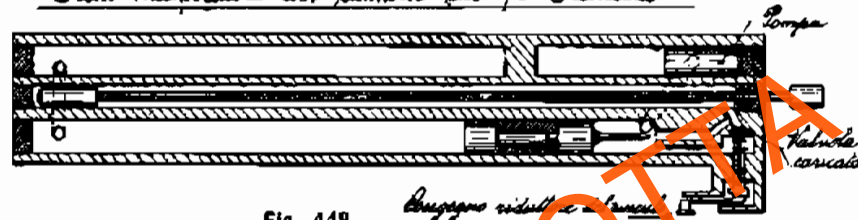

Fig. 447 Freno recuperatore del cannone da 120 colto Francese (1890)

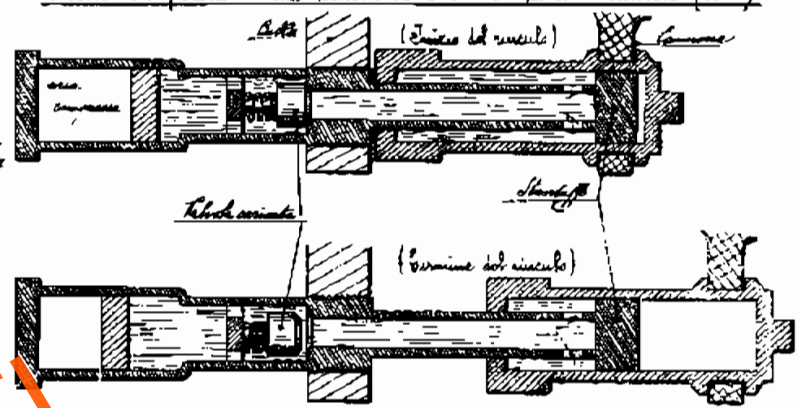

Fig. 448

Gruppo riduttore a lancetta

Freno recuperatore con asta a dettione



Fig. 451

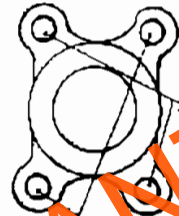

Schema dei punti elettrici per la manovra di bruciaggio

Fig. 455

Manipolatore (in posizione di zero a destra e di massima velocità)

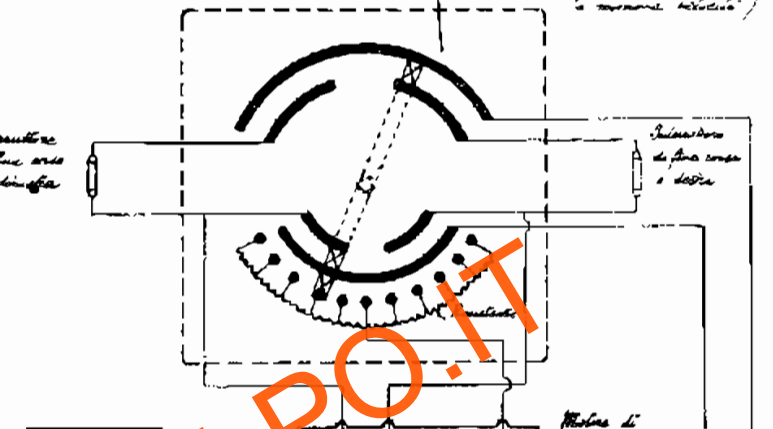

Fig. 445 Schema di valvola per recuperatore ad aria

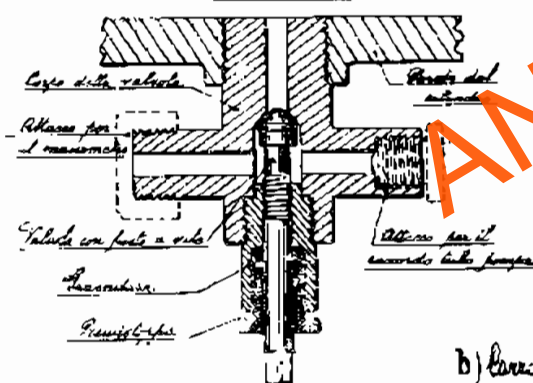

Fig. 449 Recuperatore a pistone come freno di ritorno

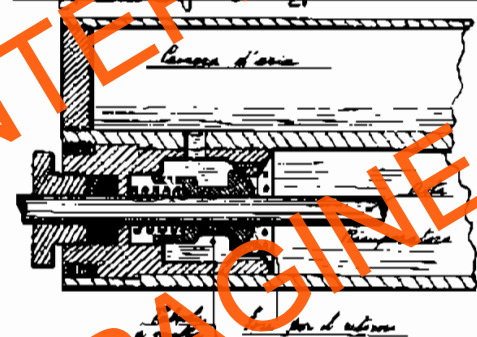

Fig. 450

Freno recuperatore dell'Obice da 280 colto

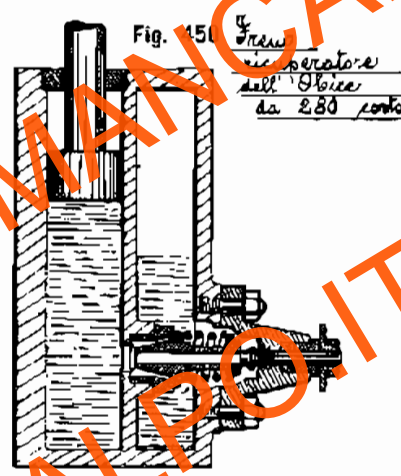
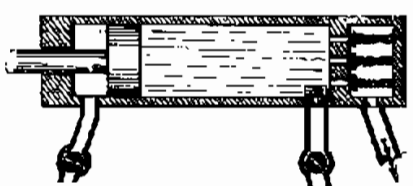

Fig. 452 Mordhio idraulico



b) Carrettino con gir.

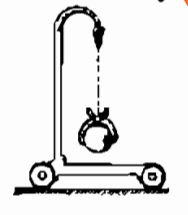
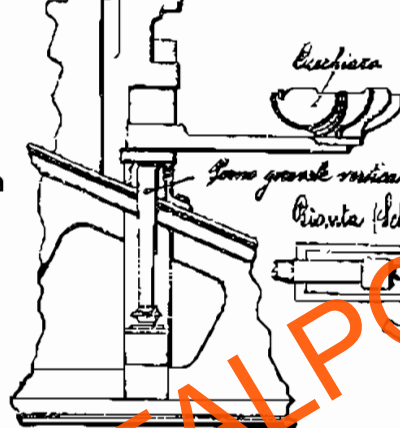
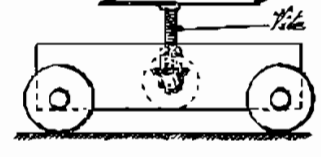

Fig. 453

a) Cucchiara di caricamento grande (per affusto a postazione)



c) Carrettino a cucchiara



b) Cucchiara di caricamento con sollevamento a molla (brev. 305/13)

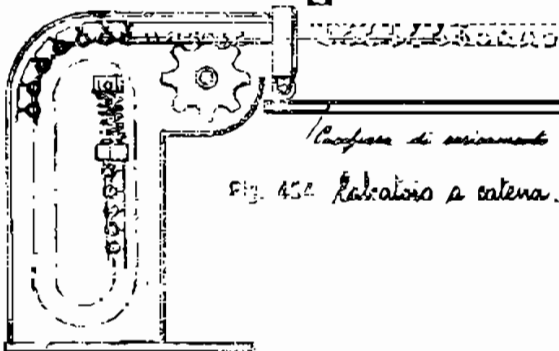
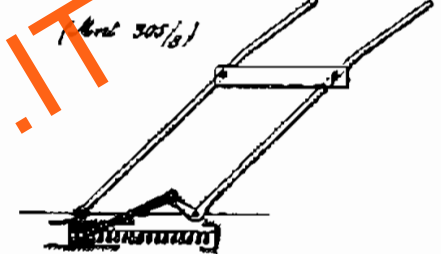
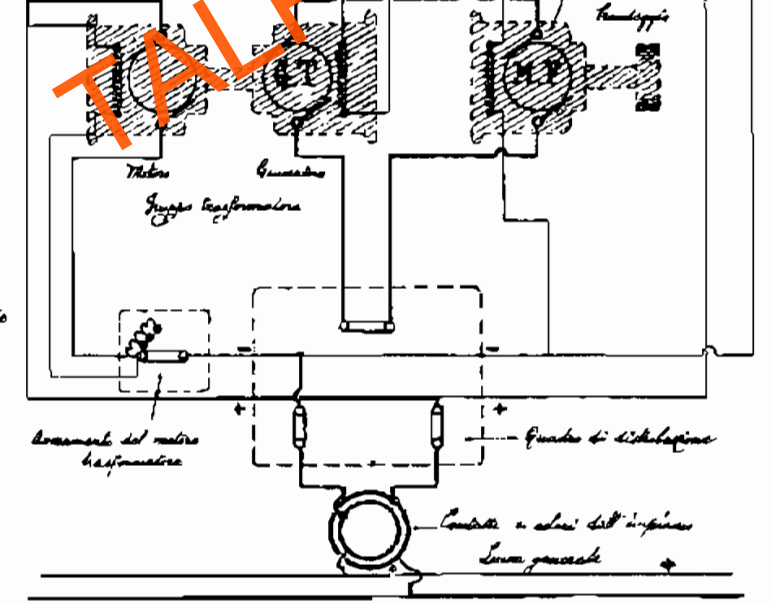
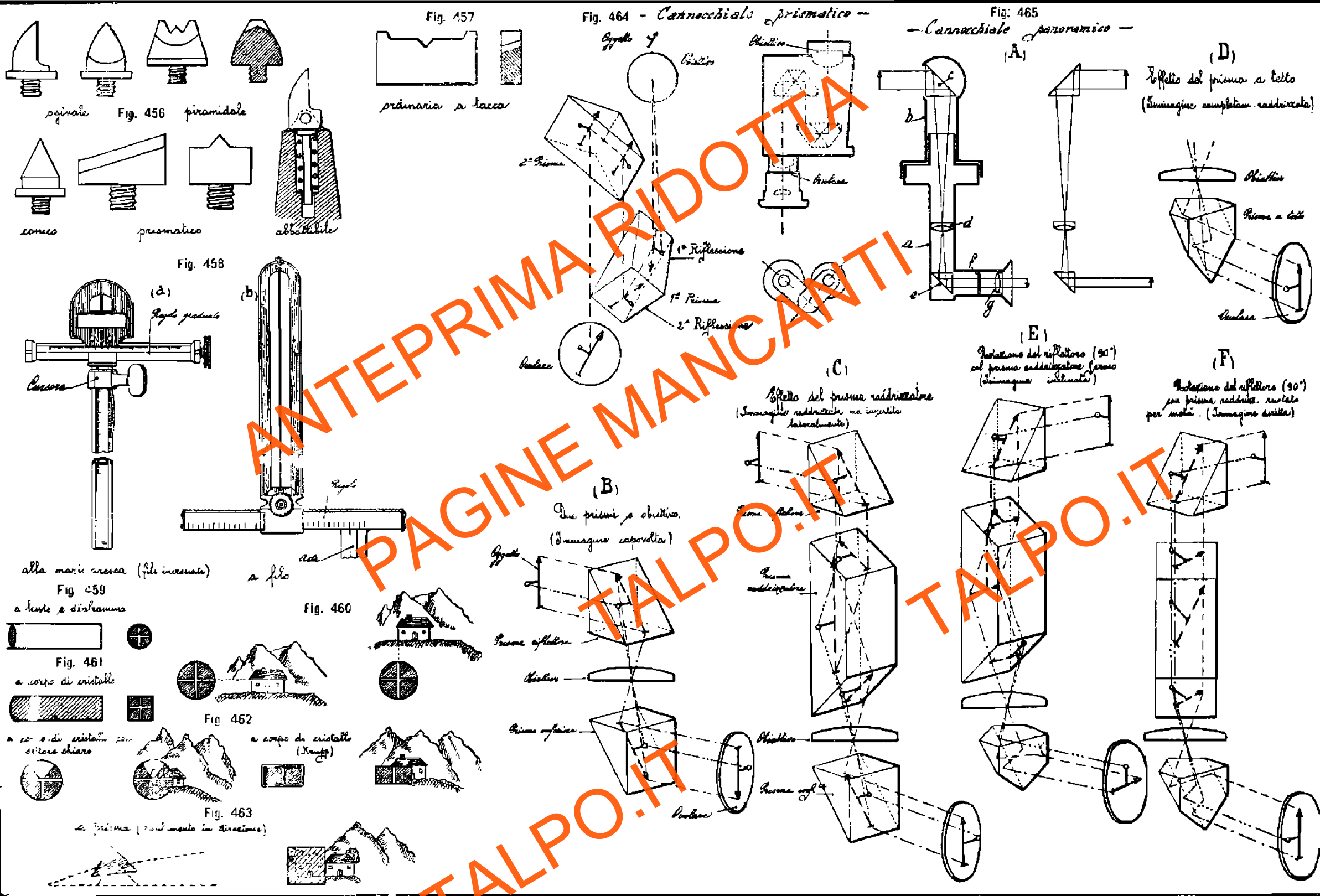

Fig. 454 Elevatore a catena.









Quadrante a livello a regolo e doppia graduazione con nonio a tamburo  
Fig. 471

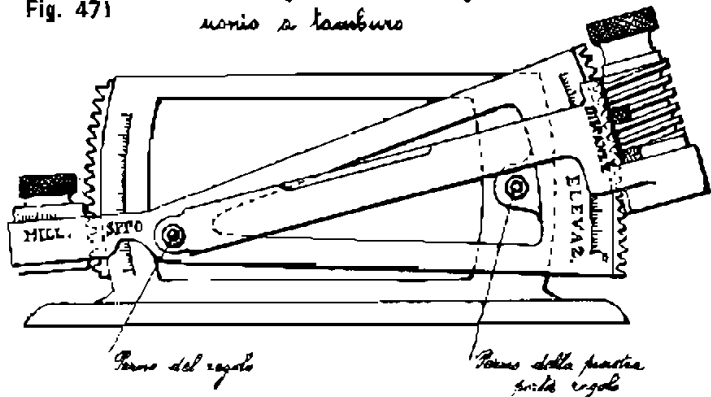

Fig. 474

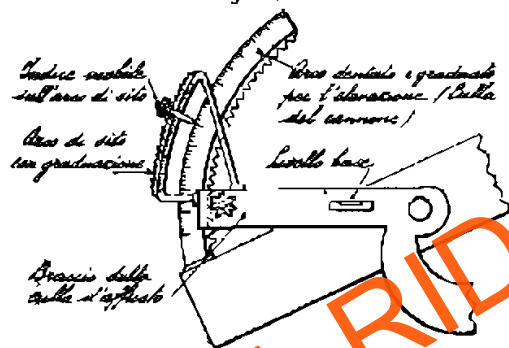

Fig. 476

Arco rettilineo a rullo e bussone

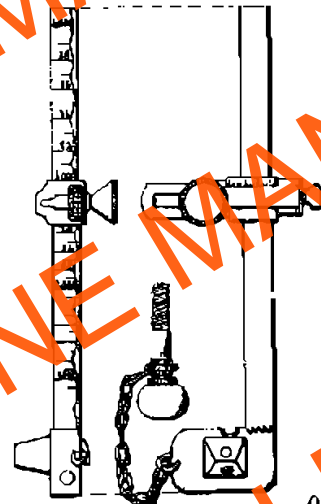
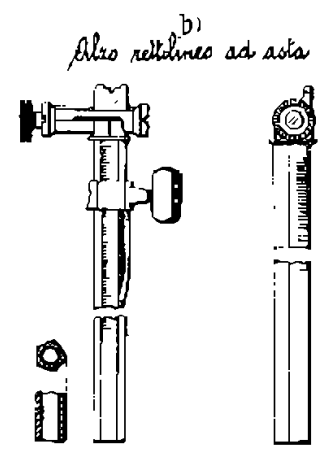
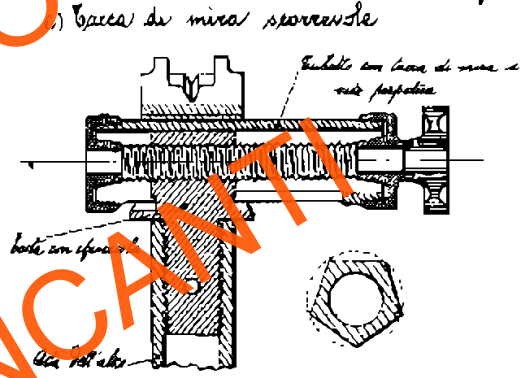
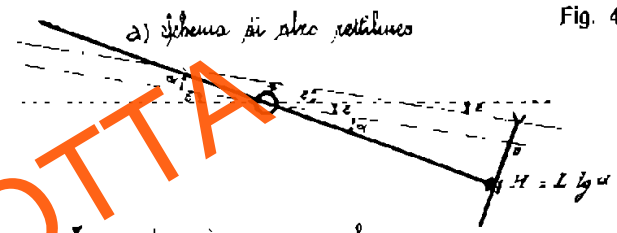

Fig. 477



Quadrante a livello con regolo arcuato  
(a)

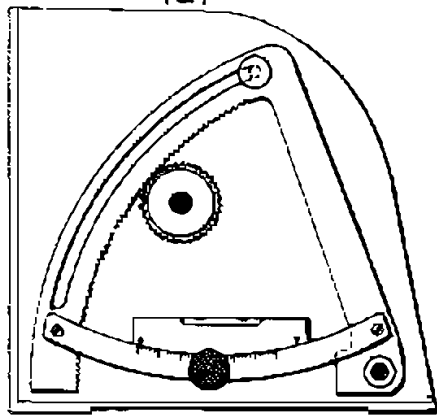

Fig. 472

Tamburo graduato di precisione a livello  
(b)

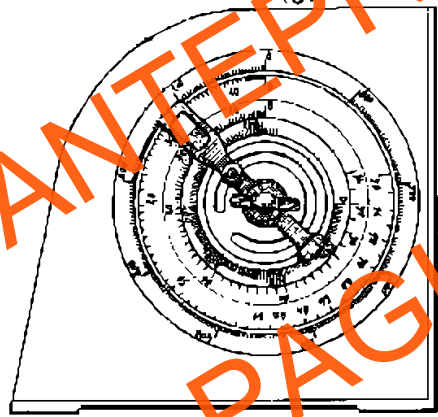

Fig. 473

Indicatore delle inclinazioni per affusto in installazione fissa

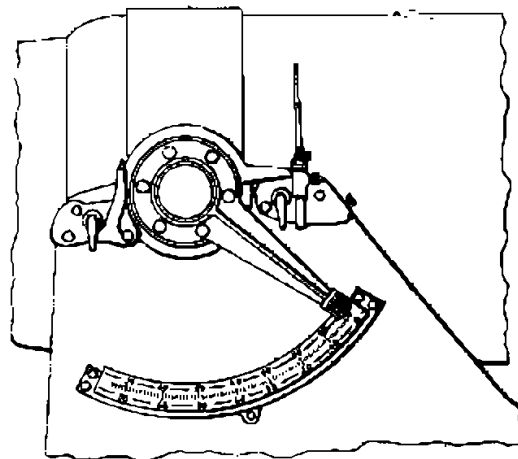

Fig. 475

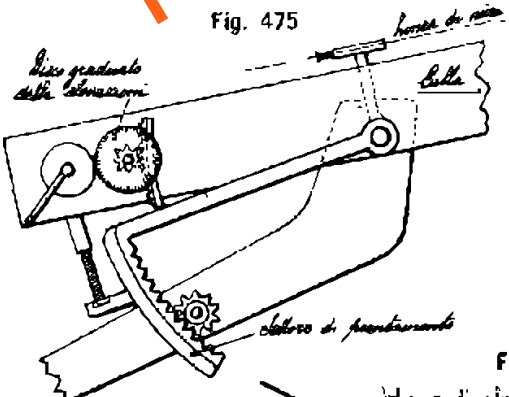
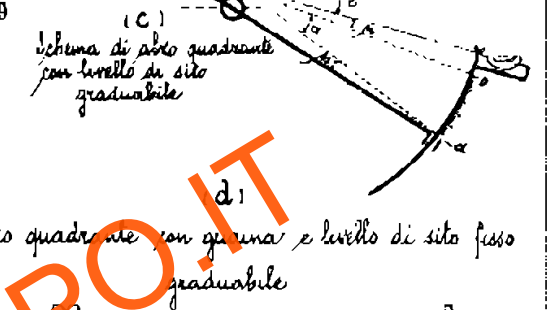

Fig. 478

Schema di altro quadrante semplice



Fig. 479



Altro quadrante con goniometro e livello non graduabile

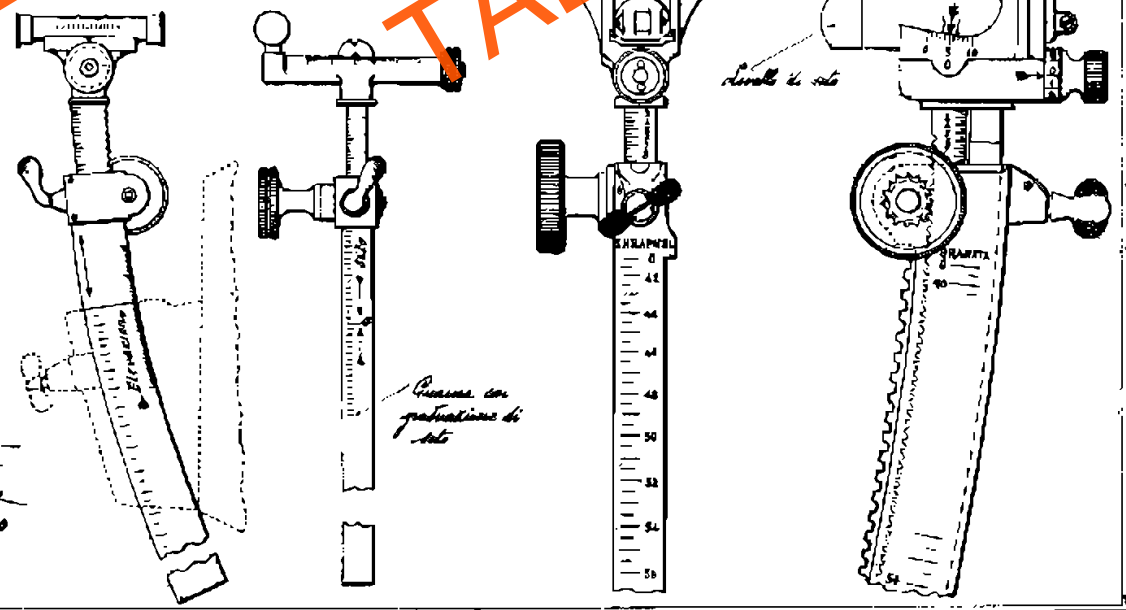



Fig. 485. alzo a slitta a doppia linea di mira

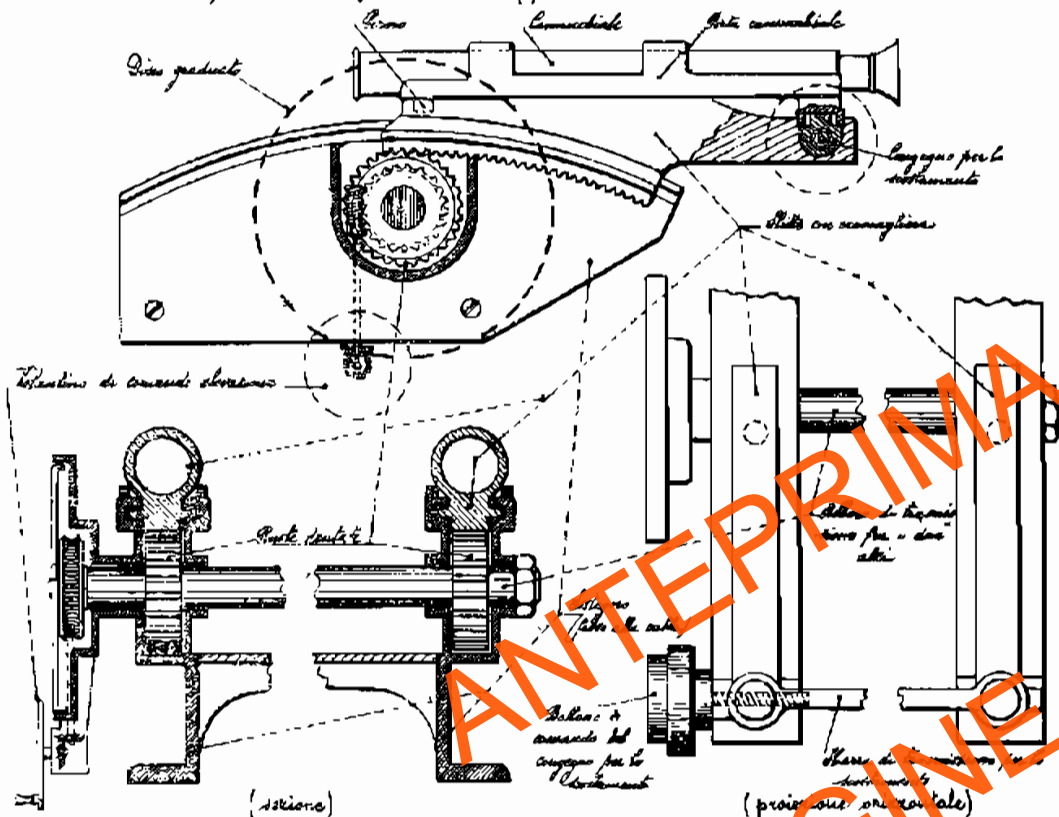

Fig. 486

Alzo a due linee di mira

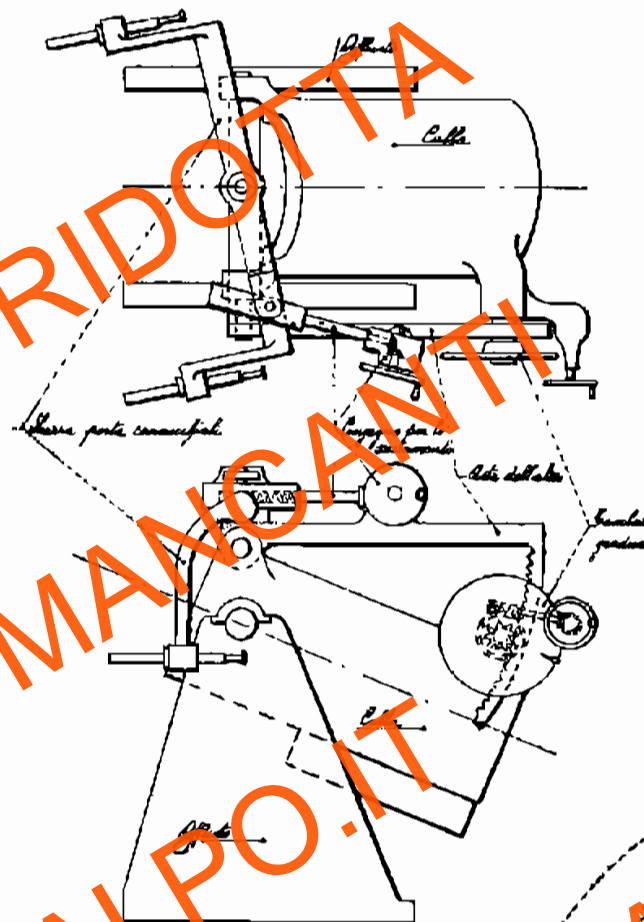

Fig. 488

Correzione dello scostamento

$XX$  = asse orizzonti orizzontale.  
 $M$  = piano verticale = piano di mira.  
 $XX'$  = asse orizzonti inclinato dell'angolo  $\theta$   
 $\delta$  = piano normale all'asse degli orizzonti su cui si muove l'asse del pezzo.  
 $MO$  = asse del pezzo o linea di mira, coincidente nella posizione iniziale = linea del piano di mira.  
 $BO$  = asse del pezzo inclinato con asse degli orizzonti orizzontale.  
 $\tau$  = piano di tiro.  
 $MB'$  = asse dell'alzo =  $h$   
 $\angle OMB$  = angolo di elevazione effettivo =  $\alpha$ .  
 $MB'$  = asse dell'alzo dopo la correzione.  
 $AO$  = traccia del piano di tiro sul piano orizzontale.  
 $\angle MOA = \epsilon$ , variaz. di direzione derivante dallo scostamento.

Fig. 489

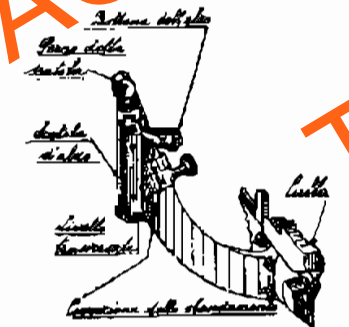

Fig. 490

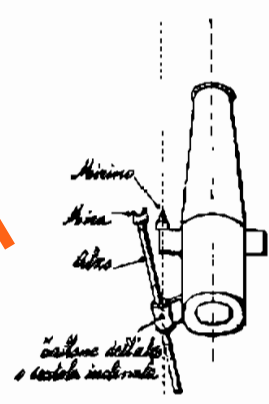
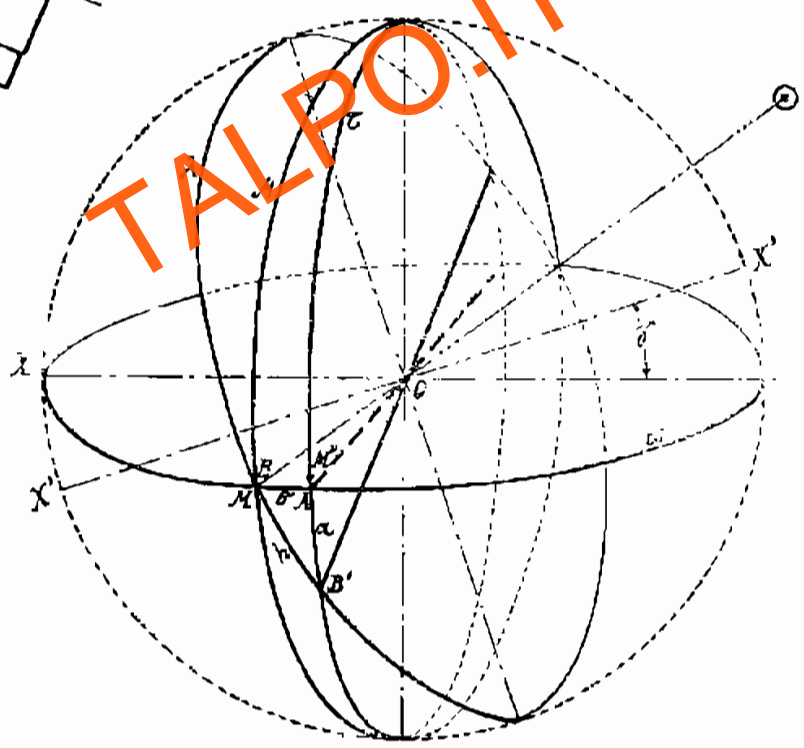
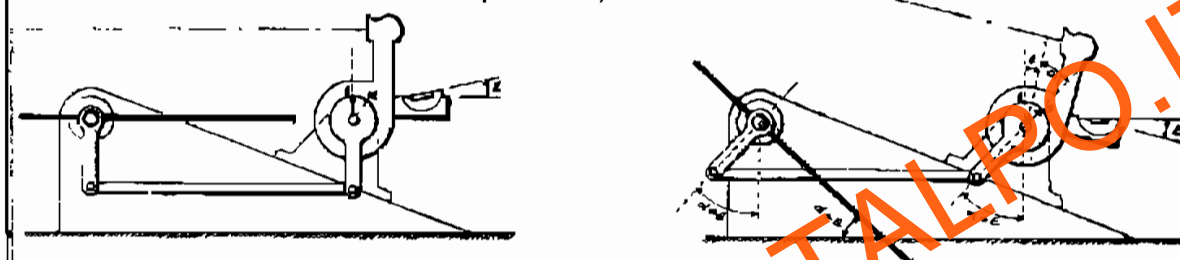

Fig. 487

Schema di alzo a tamburo su sostegno fisso all'affusto (transmissione)







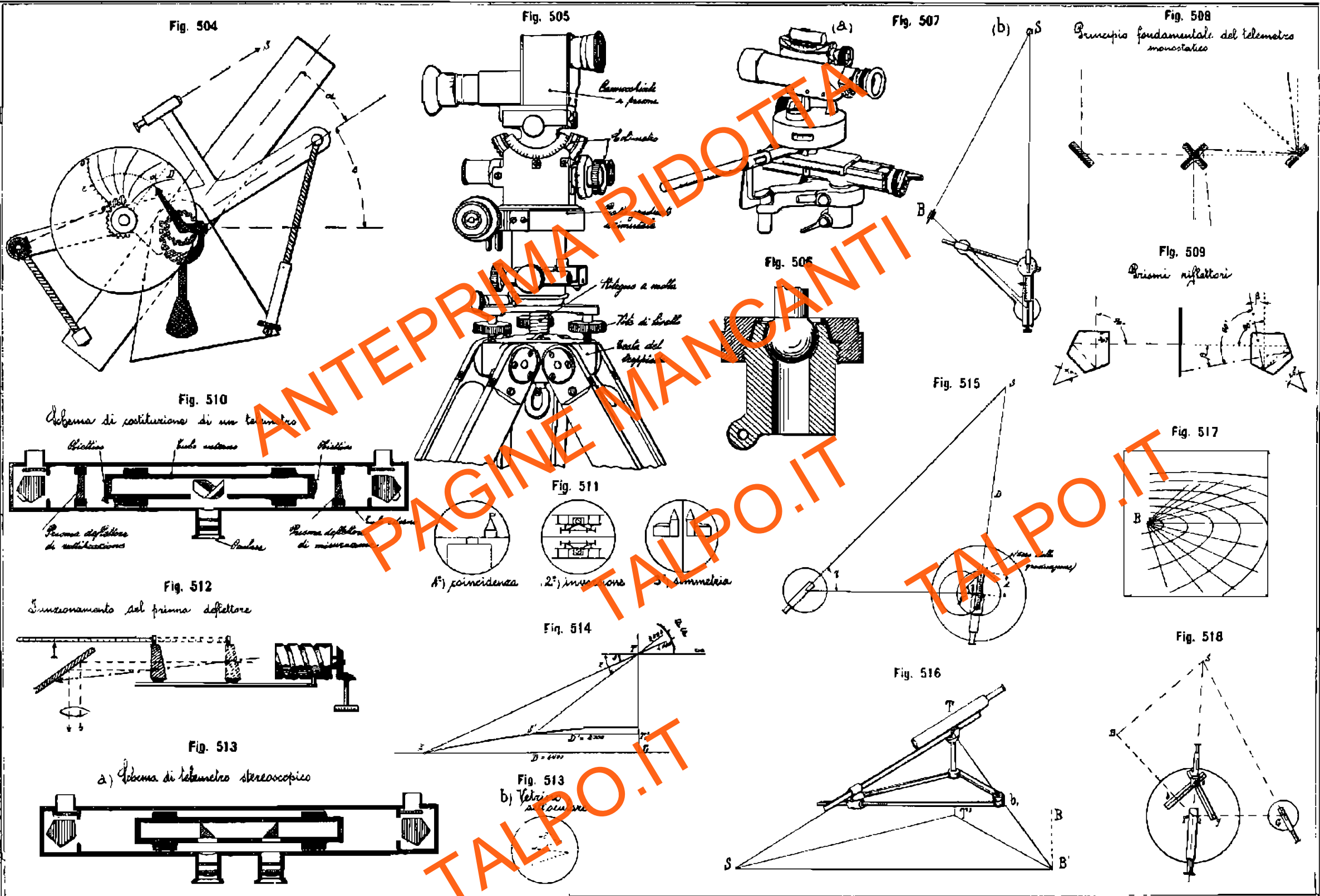



Carro per munizioni (o cassette) a ribaltamento

Fig. 574

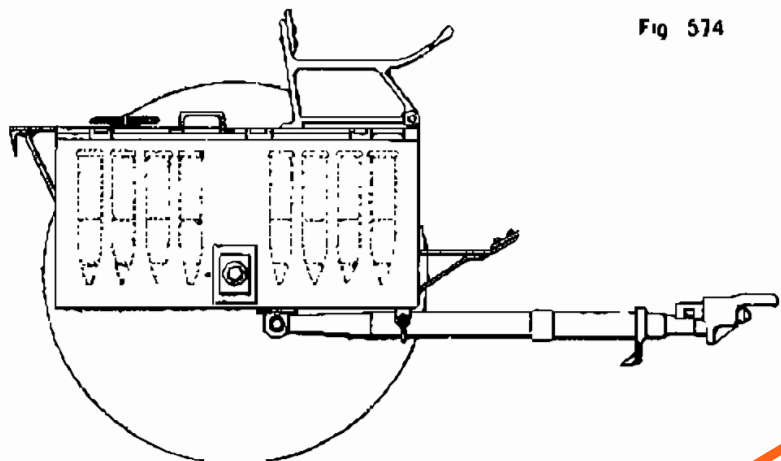

Carro bocca da fuoco — (Obice da 149/12 Mod. 14. Frada)

Fig. 578  
(a)

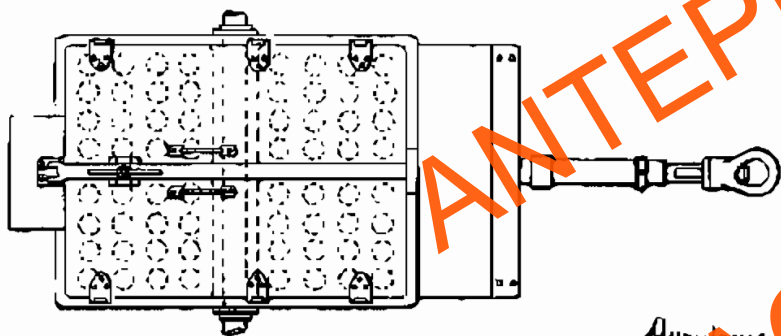
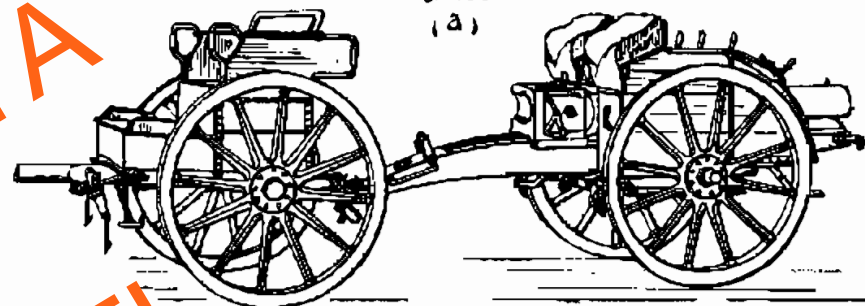
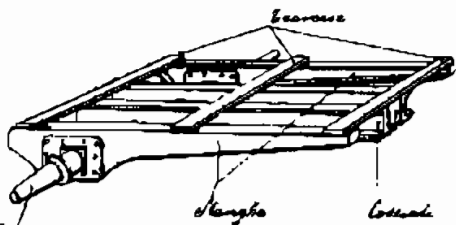

Fig. 575

Avanzone a telaio



Avanzone a telaio da farvi ad angolo

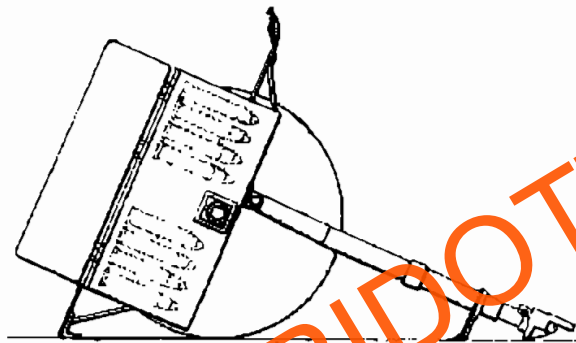
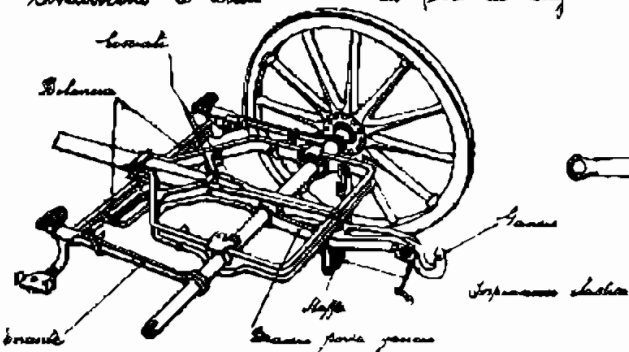
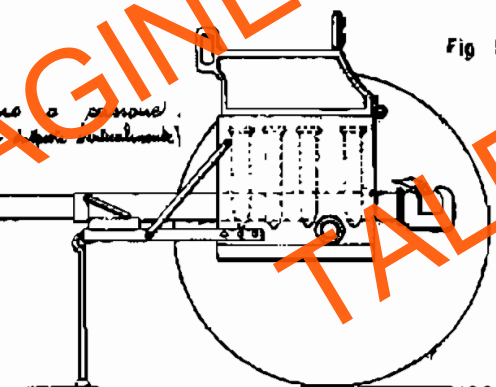
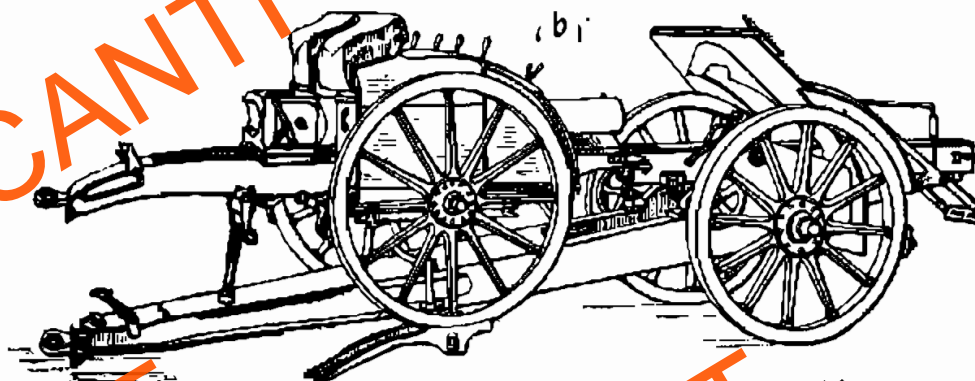
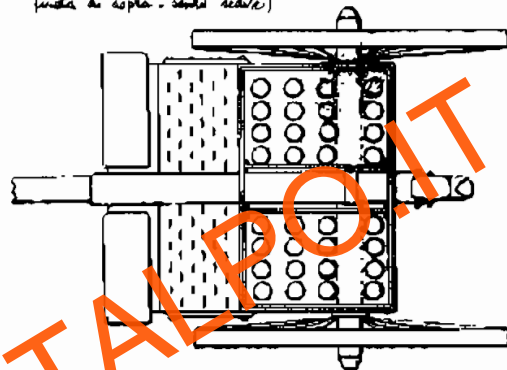

Fig. 576

Avanzone a pannello (munizioni a spole presentate)



(vista di sopra - senza ruote)



Avanzone a pannello (munizioni a spole presentate)

Fig. 577

Avanzone delle piroette nel cassone

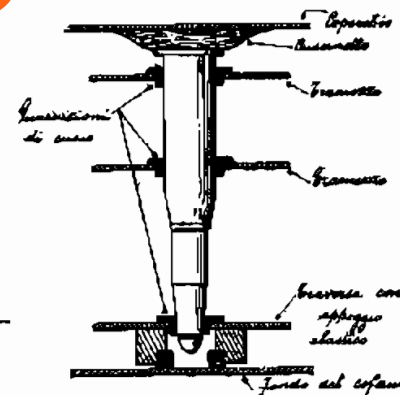
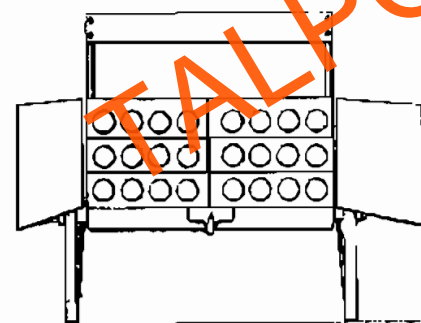
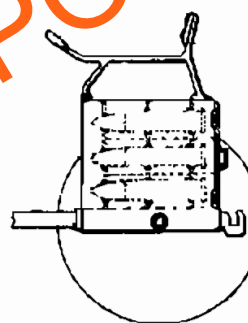
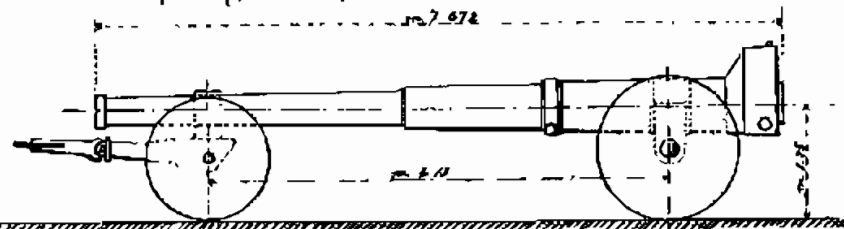
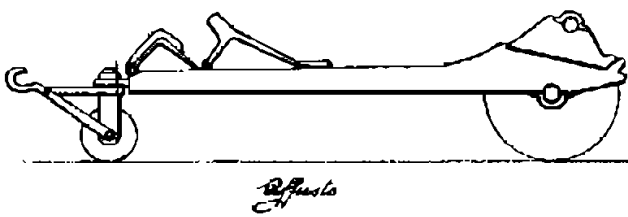

Fig. 579

Carro bocca da fuoco. (Carri francesi da 220 L.T.R. - 1873 -)



Schema della scomposizione per il traino in montagna dell'obice da 100/17 Mod 14. (Scala app. 1/40).  
Fig. 580



Alfusto

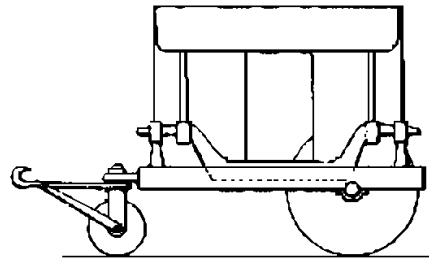

Carrello per rota e scudo

Schema della scomposizione per il traino primario dell'obice da 100/17 Mod 16. (Scala app. 1/40).  
Fig. 581

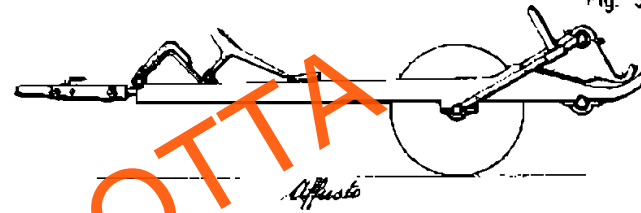

Alfusto

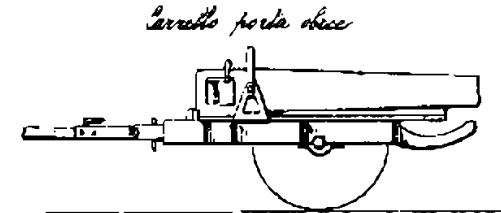

Carrello porta obice

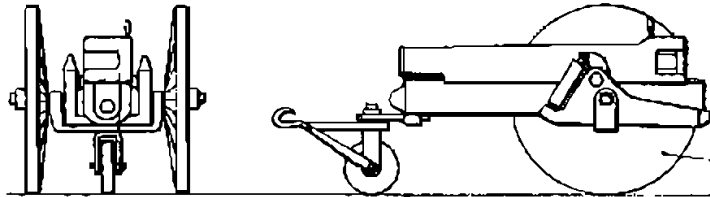

Carrello per obice e cartucce

Fig. 582

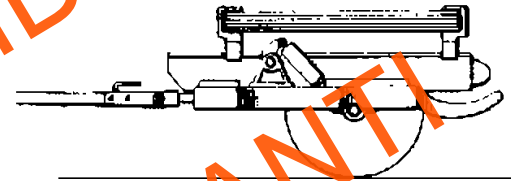

Carrello per rota e scudo

b) Armatura per basto

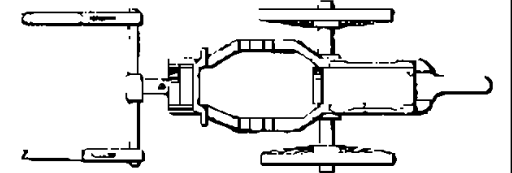

Carrello vuoto

Fig. 583

-a- Gallette irregolari.

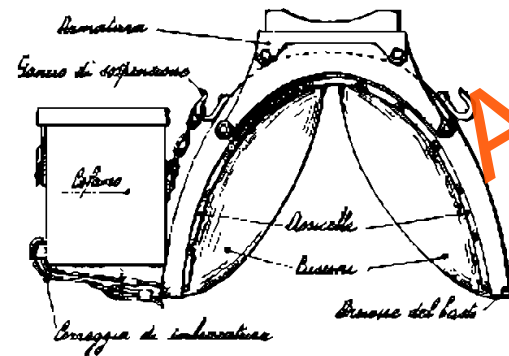

(a)

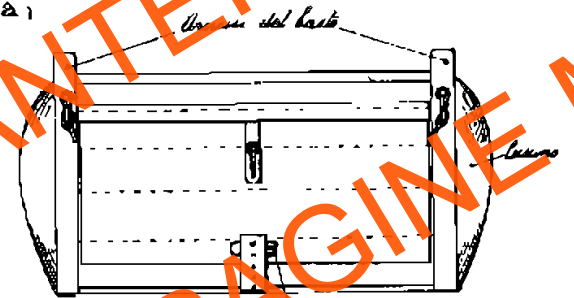

Armi del basto

Carri

Camera per cartucce d'imbucatura

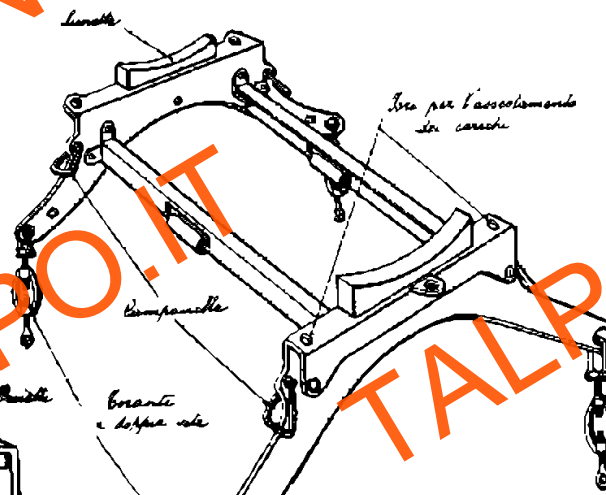

Tras per l'assolimento dei carichi

Compendio

Brante e l'appa. etc.

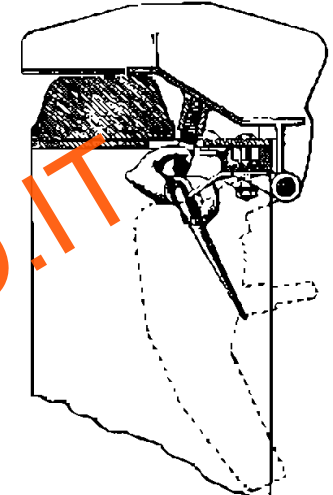

c) Carante a doppia vite.

b) Piattaforme mobili

c) Cassole querechi e imbelle

(d) Armatura per cassetta munizioni

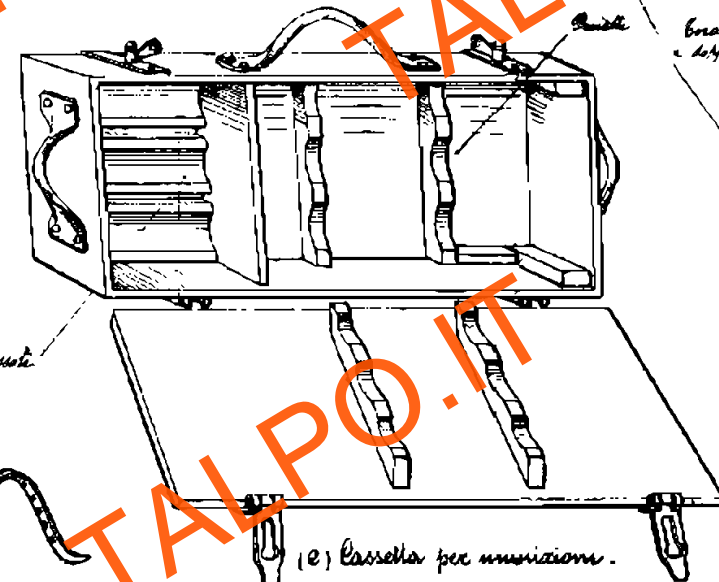
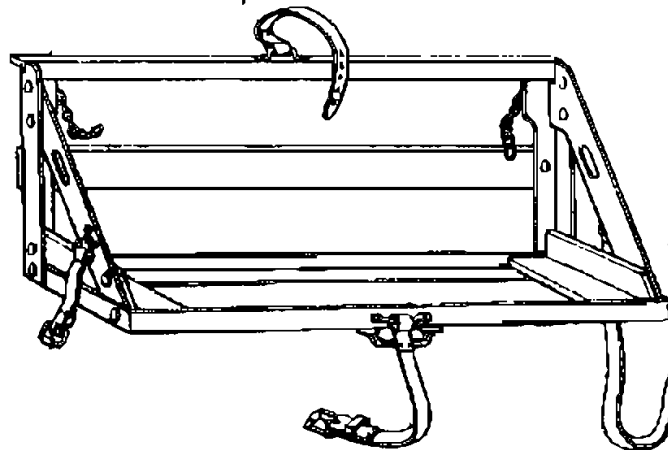

(e) Cassetta per munizioni.

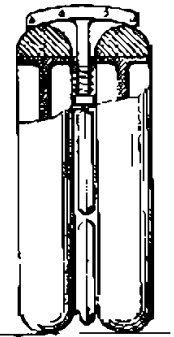
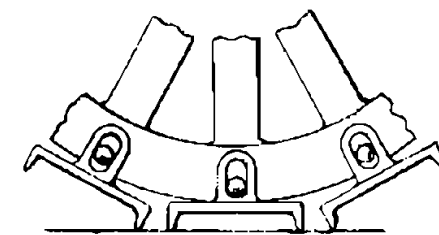

Fig. 584 Ringhi antiskidanti.

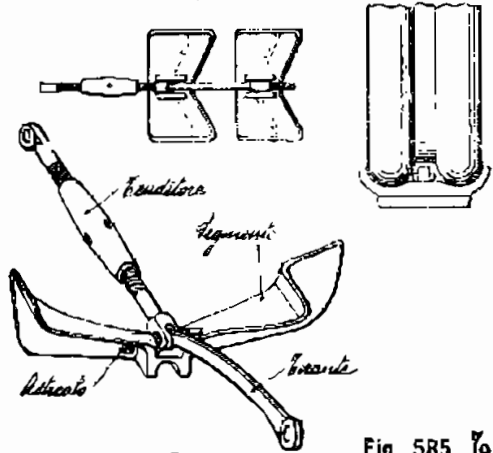

Fig. 585 Trattore Pavese

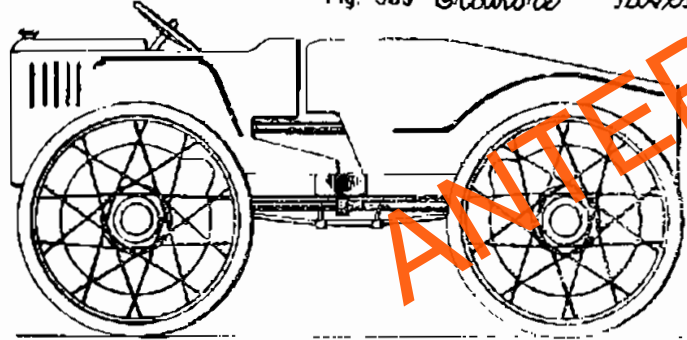

Fig. 584 bis - Tipo di veicolo a pneu di quattro ruote.

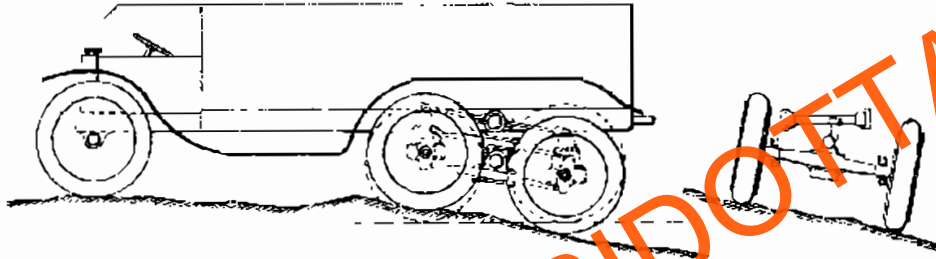

Fig. 586



Fig. 588 Sistemazione generale del tipo Holt.

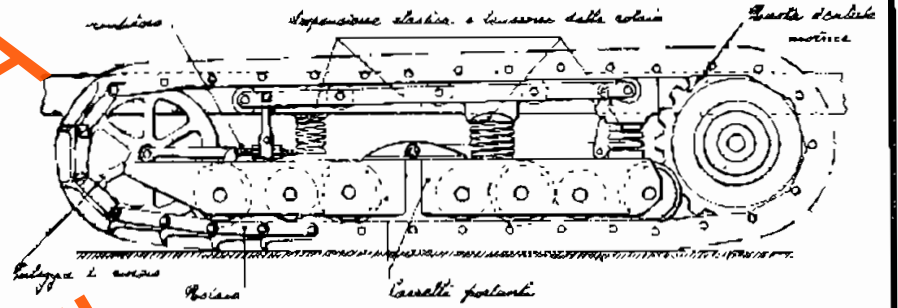

Fig. 589 Tipo di veicolo misto

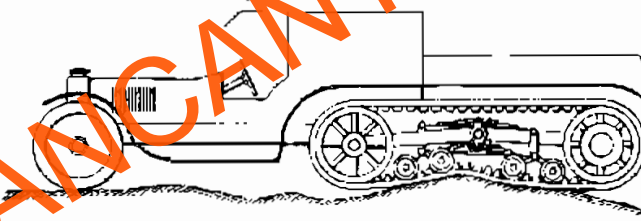

Fig. 592

Rotas continue con rulli mobili

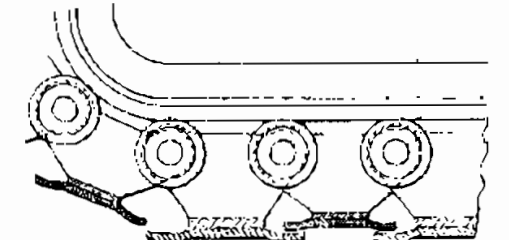

Fig. 590

Motoroma tipo Holt

Motoroma tipo Holt

Rotas motore

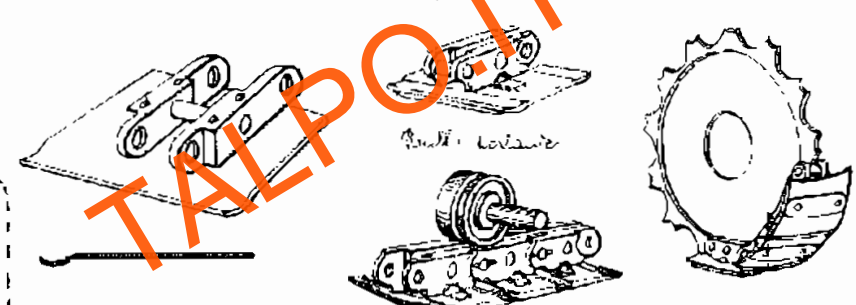
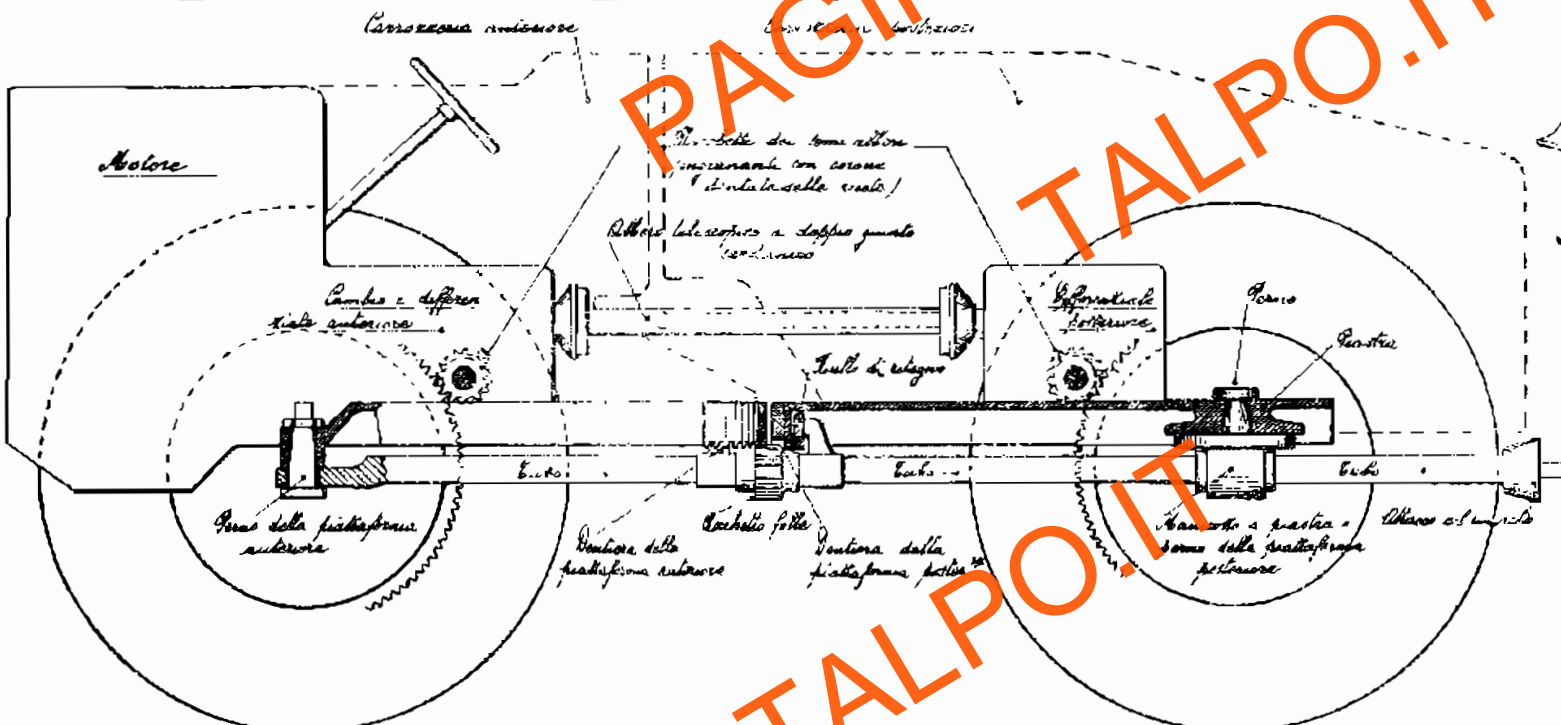
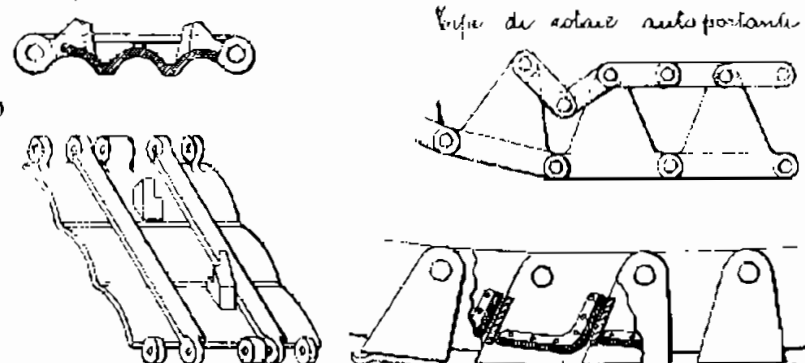

Fig. 591

Tralicorno tipo Peckolt

Fig. 593

Veicoli di motore autoportante



ANTEPRIMA RIDOTTA  
PAGINE MANGANTI  
TALPO.IT

*Sospensione elastica a balestra*

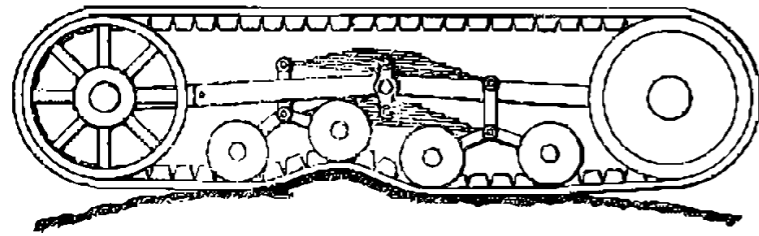

Fig. 594  
*Rotida Kegresse*

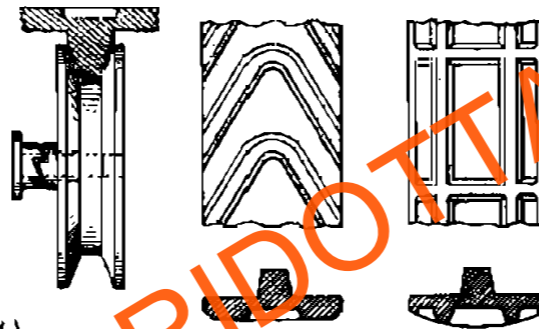

Fig. 598

*Sospensione elastica a catena o a cavo metallico*

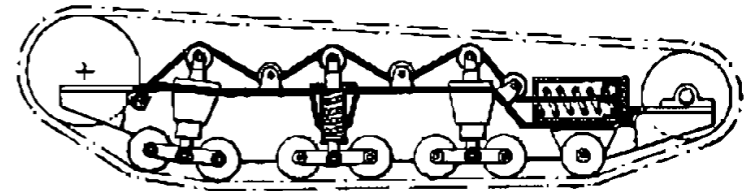

Fig. 595

*Sospensione elastica trasversale*

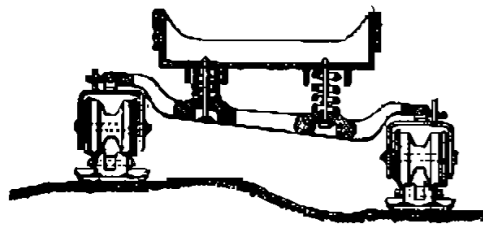

Fig. 598  
*(tipo Saint Chamond)*

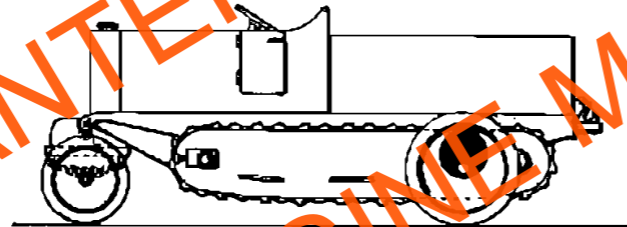
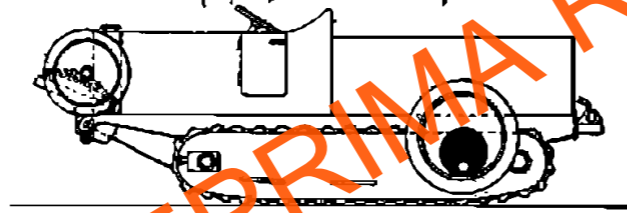
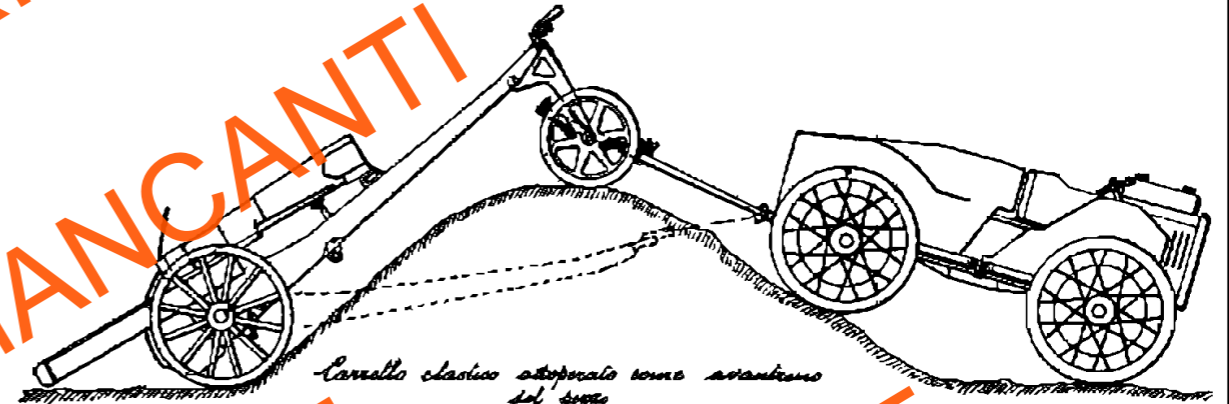
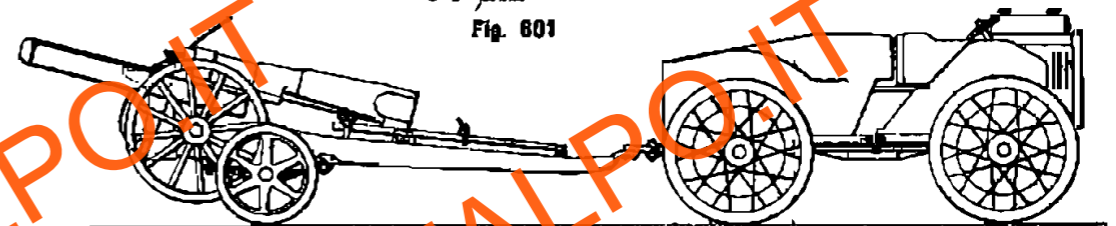

Fig. 600



*Carretto classico adattato come avanzatore del pezzo*

Fig. 601



*Carretto elastico adattato per il trasporto del pezzo*

Fig. 597

*Veicolo trasformabile (tipo Saint Chamond)*

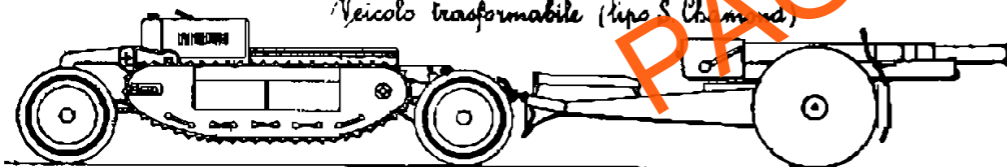

Fig. 599

*(tipo Christie)*

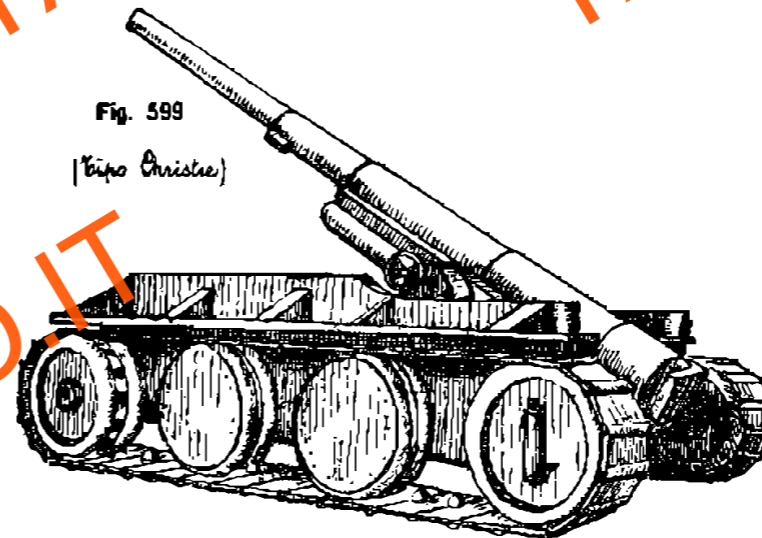

Fig. 603

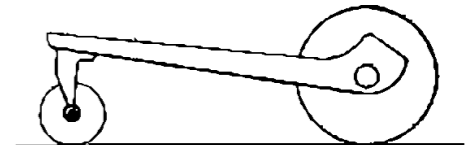
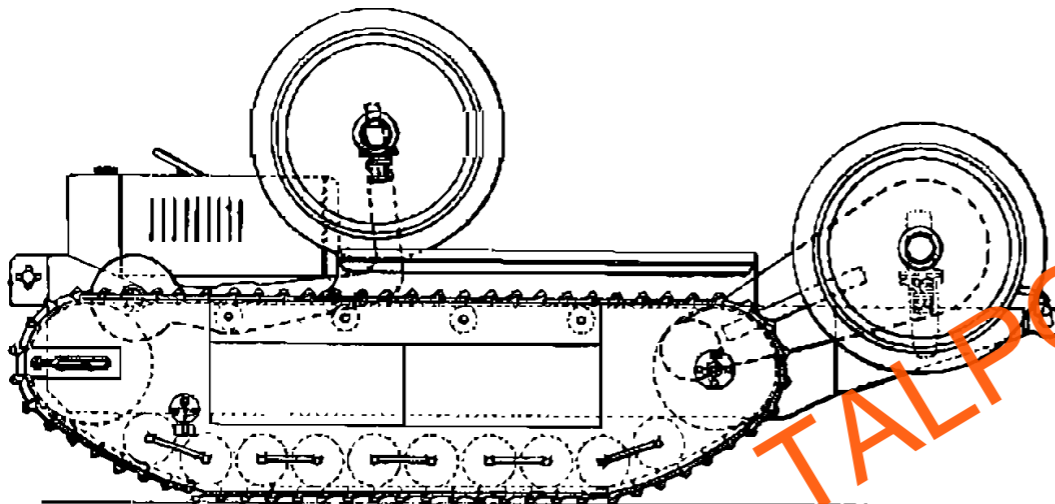

Fig. 604



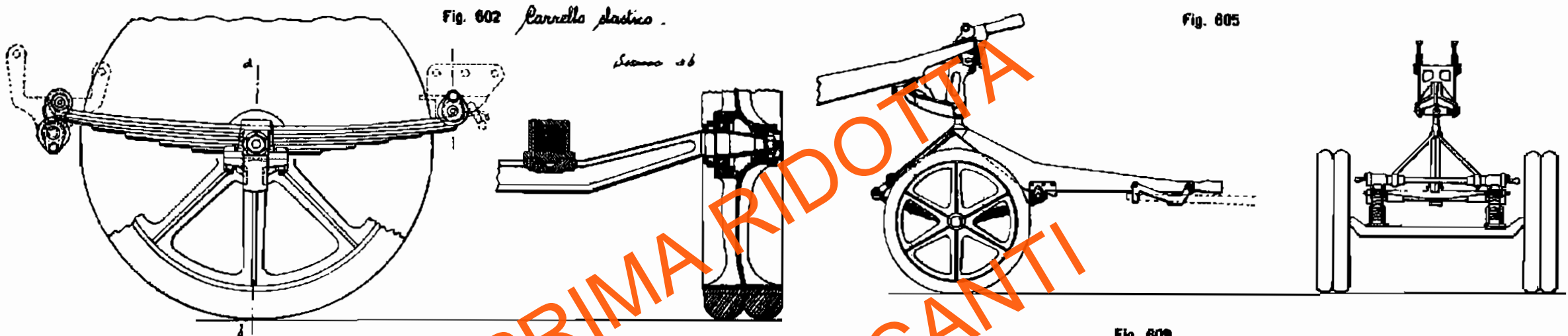

Fig. 606 Rimorchio bocca da fuoco

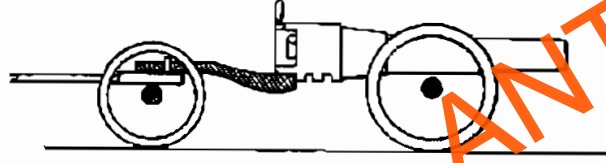

Fig. 607 Carro que per rimorchio piattaforma

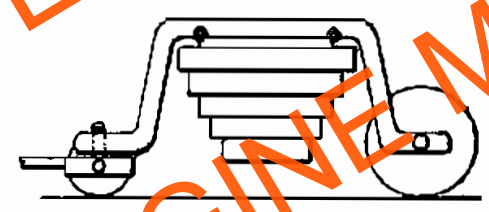

Fig. 608

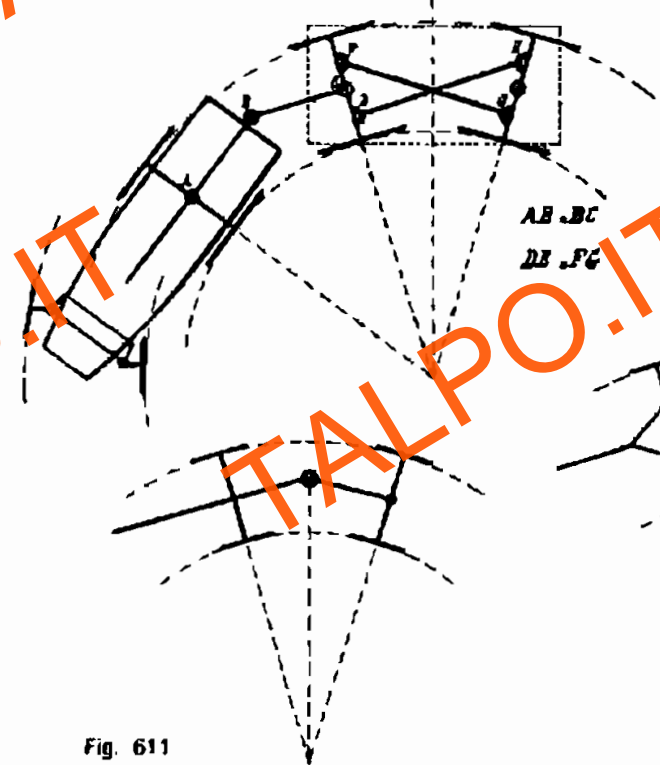

Fig. 610

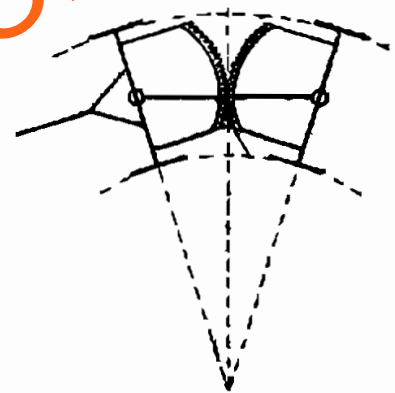

Fig. 607 bis

Carrozza da 220 L.T.R. - 157 - (3 anni a)

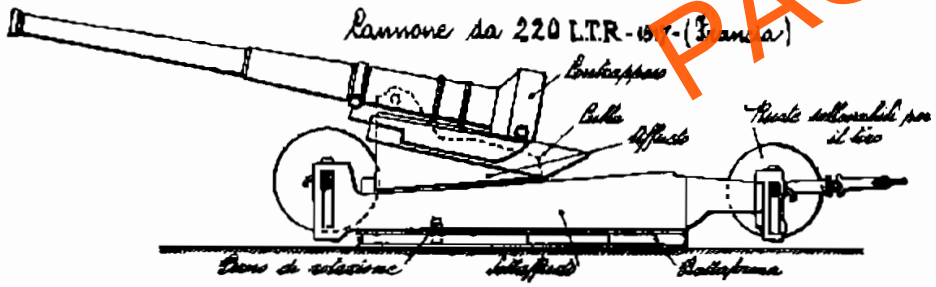
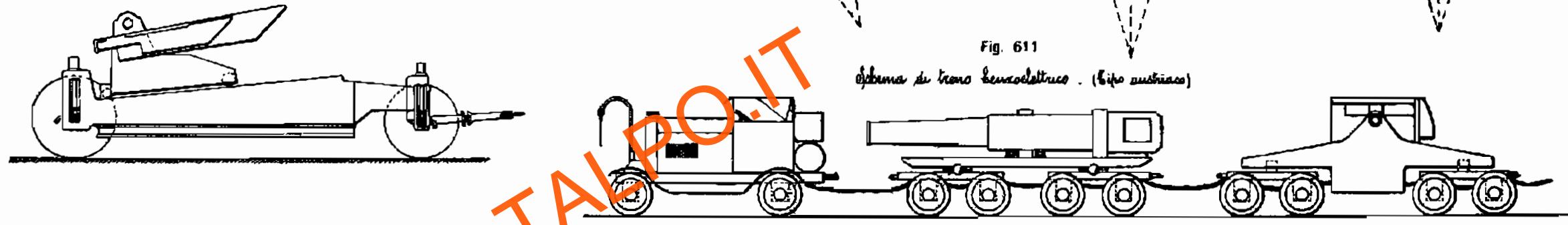

Fig. 609



Fig. 611

Schema di treno benzoelettrico. (Tipo austriaco)



Carro generatore

Vettura bocca da fuoco

Vettura motore

ANTEPRIMA RIDOTTA  
PAGINE MANCANTI  
TALPO.IT

Fig. 612.

Lingottiere per lingotti da 60 ad 85 tonn.<sup>ca</sup>  
(Armstrong).

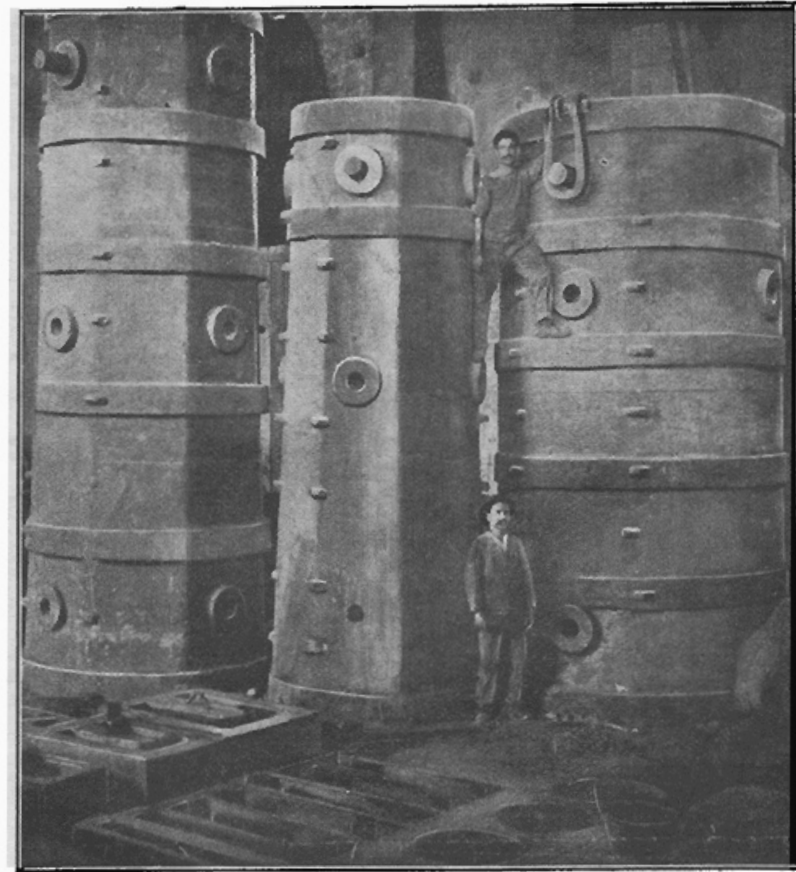

Fig. 613.

Lingotto di acciaio di 54 tonn.<sup>ca</sup>  
(Armstrong).



Fig. 614.

Pressa di 2000 tonn.<sup>ca</sup> per la fucinazione  
dei masselli — (Armstrong).

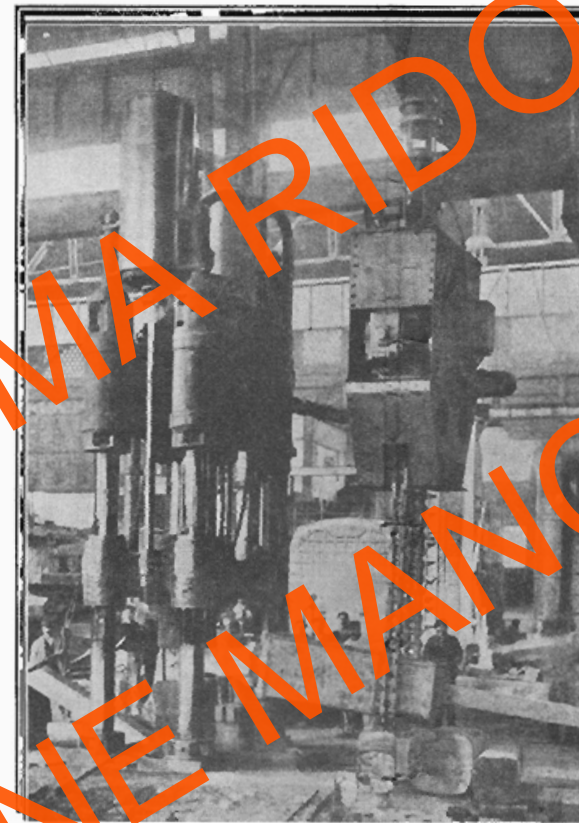

Fig. 616.

Forno verticale per la tempera dei tubi ed elementi  
per cannoni. (Ansaldo).

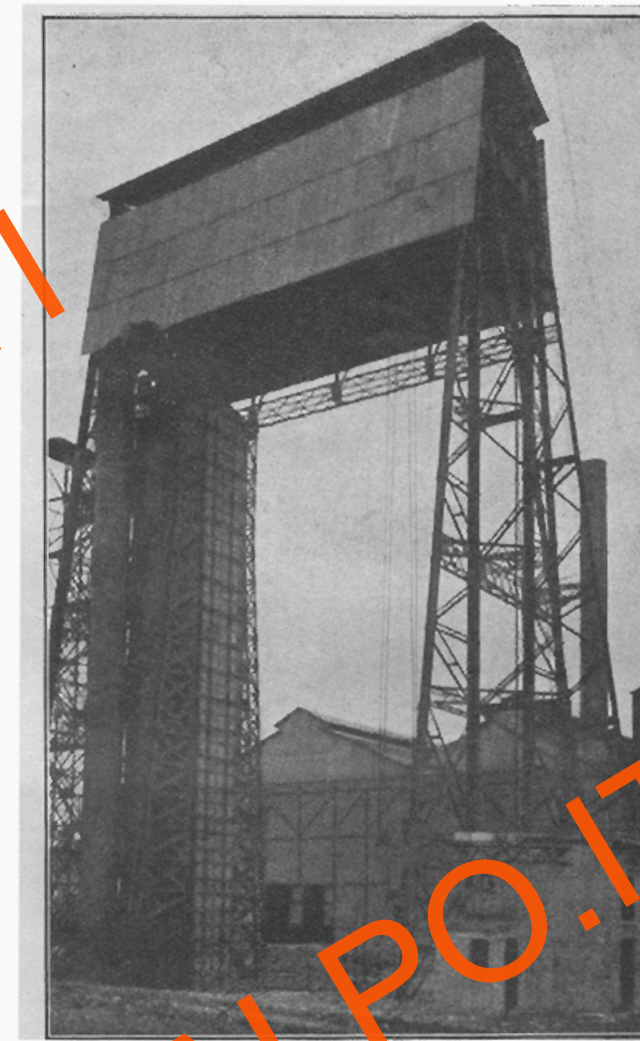

Fig. 617.

Cerchiamento di un cannone da 305 m/m.  
(Armstrong).



Fig. 615. Trapanatura. (Ansaldo).

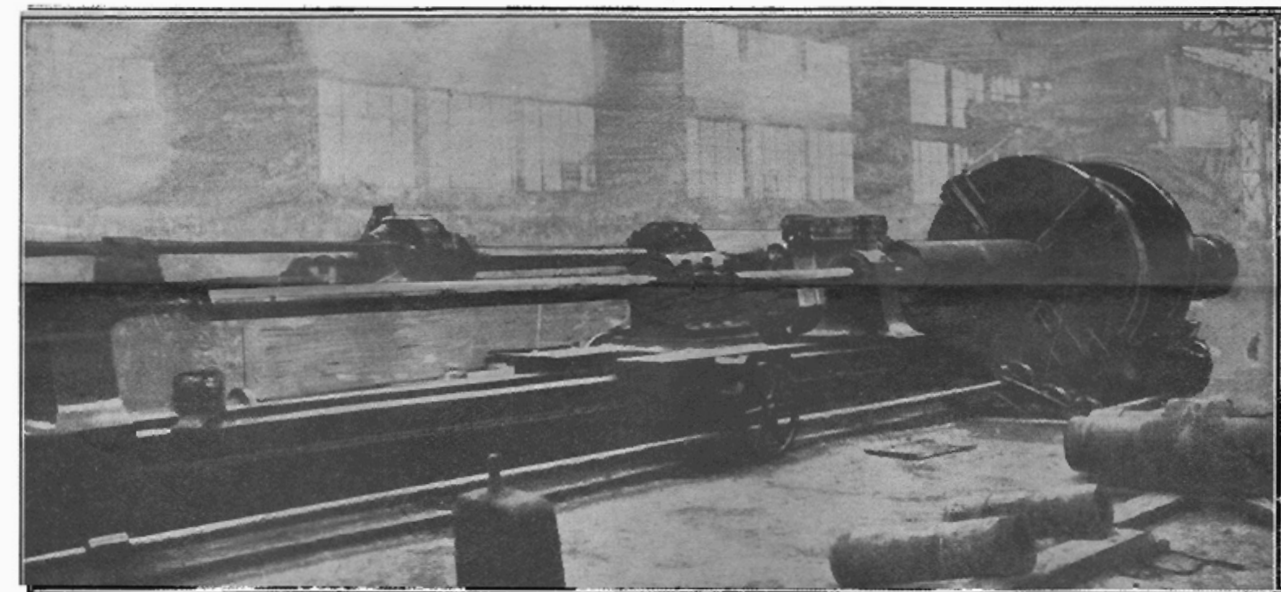

Fig. 623.

Pressa verticale.

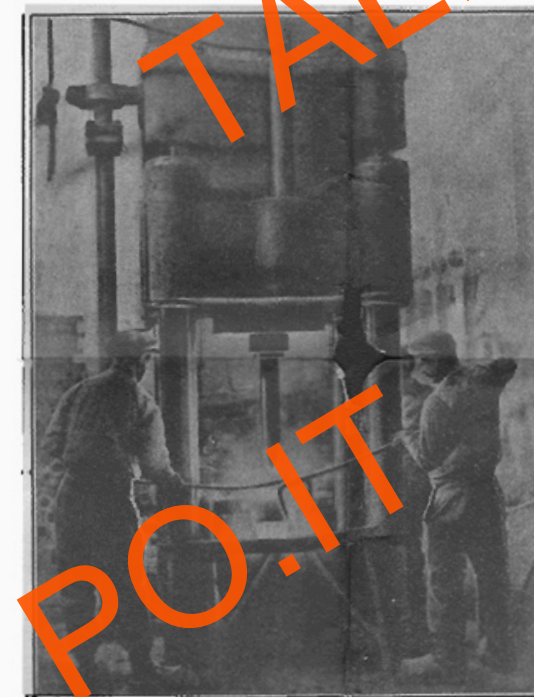
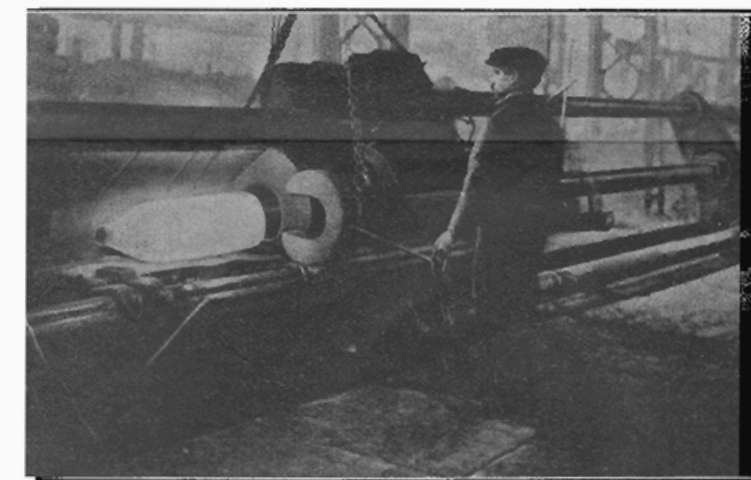

Fig. 624.

Pressa orizzontale.



ANTEPRIMA RIDOTTA  
PAGINE MANCANTI  
TALPO.IT

Fig. 618 *Apparecchio a rigare con asta*

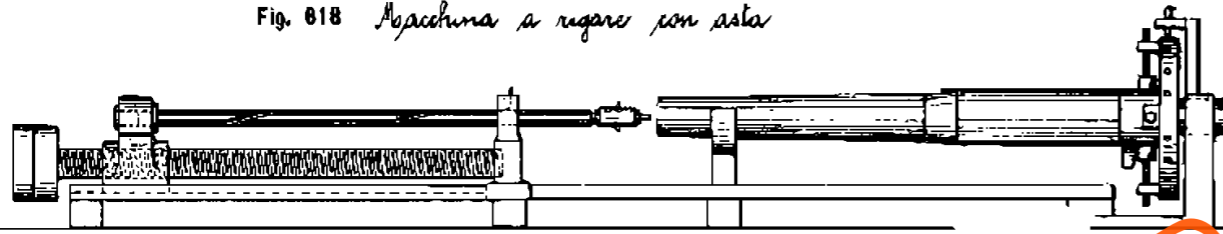

Fig. 621 *Innatura del massello*

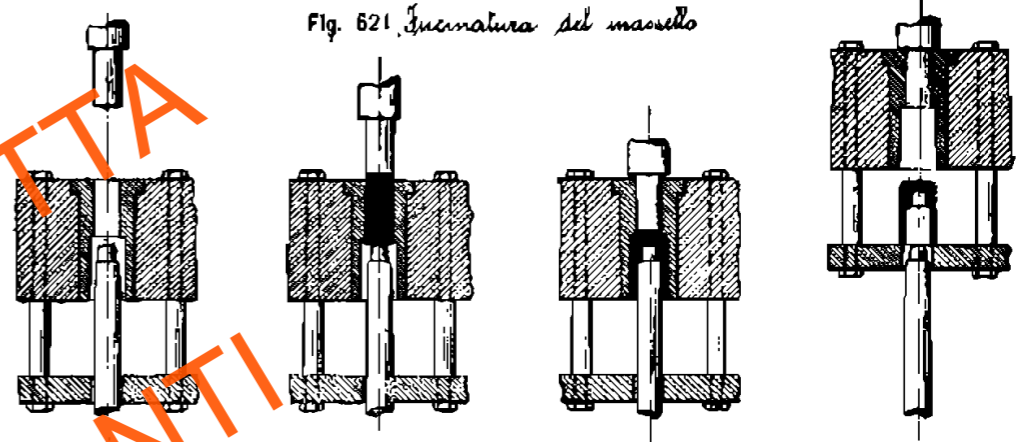

Fig. 619 *Regolo sviluppo*

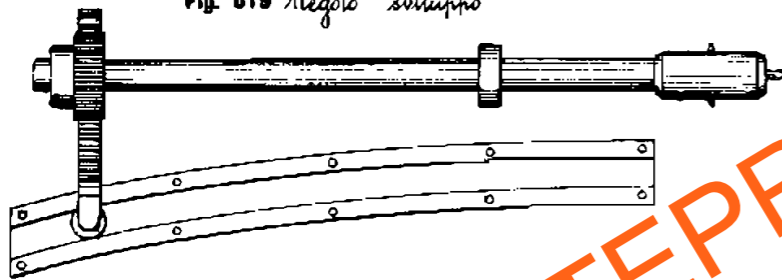

Fig. 622 *Grappatura*

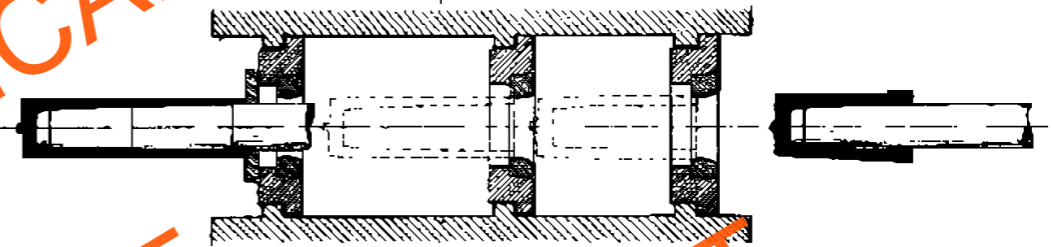

Fig. 620 *Testa a rigare*

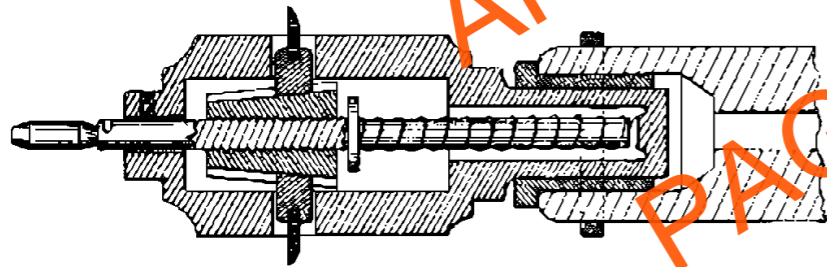

Fig. 625

*Avanzamento*

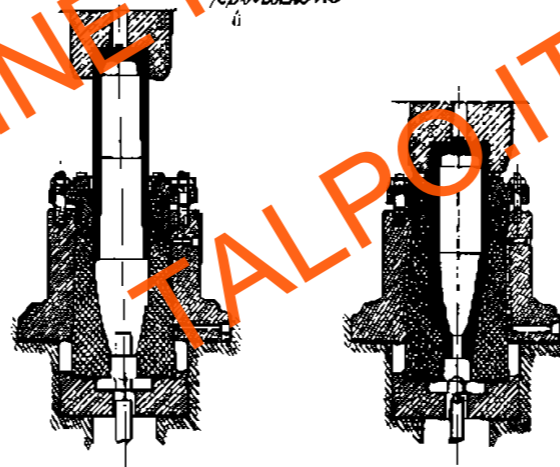

Fig. 629

*Verifica del centro di gravità*

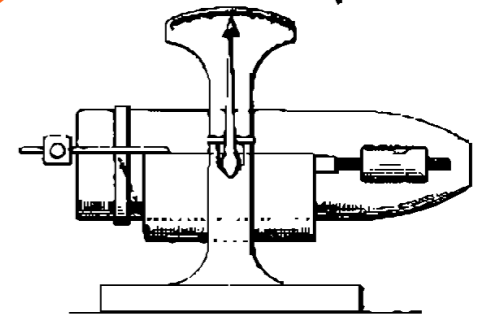

Fig. 626

*Tempera per aspersione*

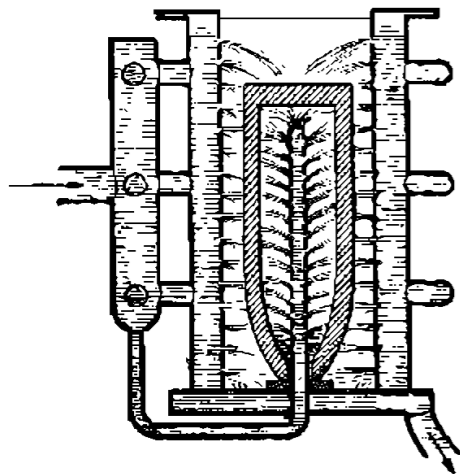

Fig. 627

*Tempera per immersione*

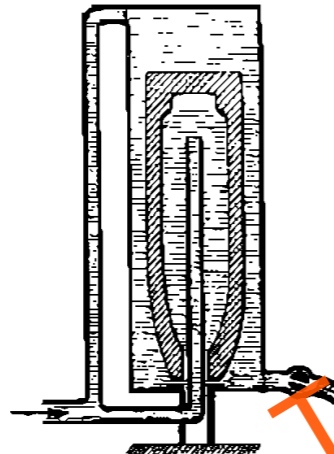

Fig. 628

*Temperazione*

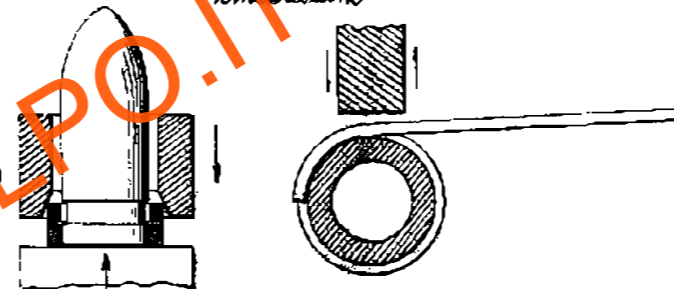
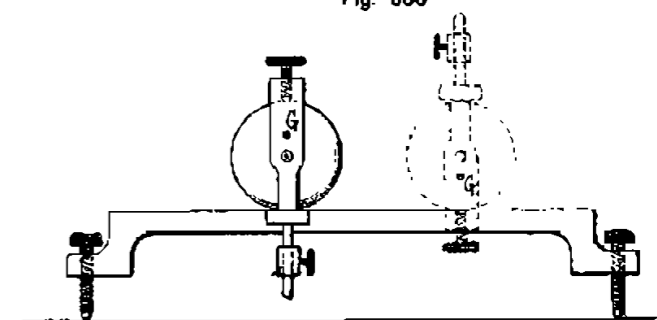
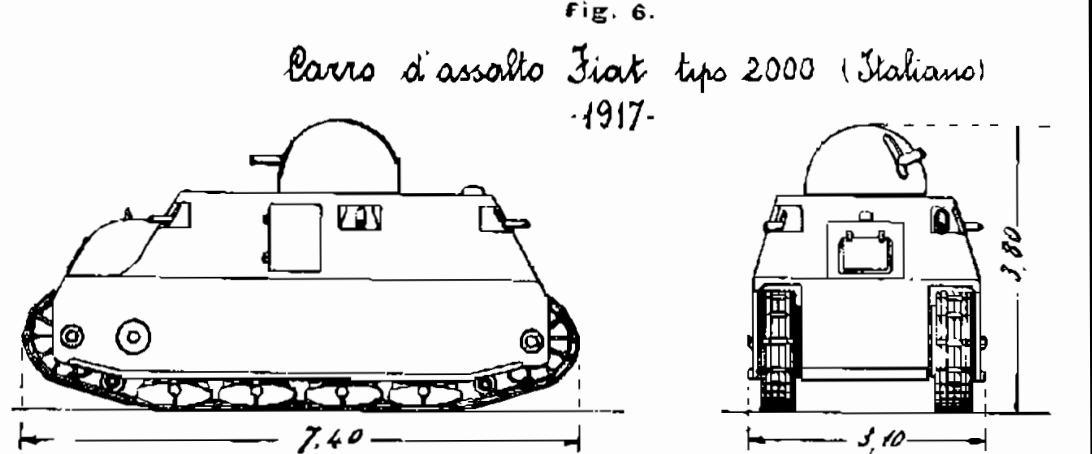
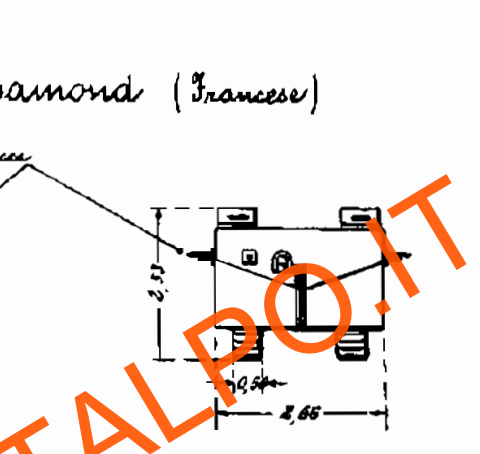
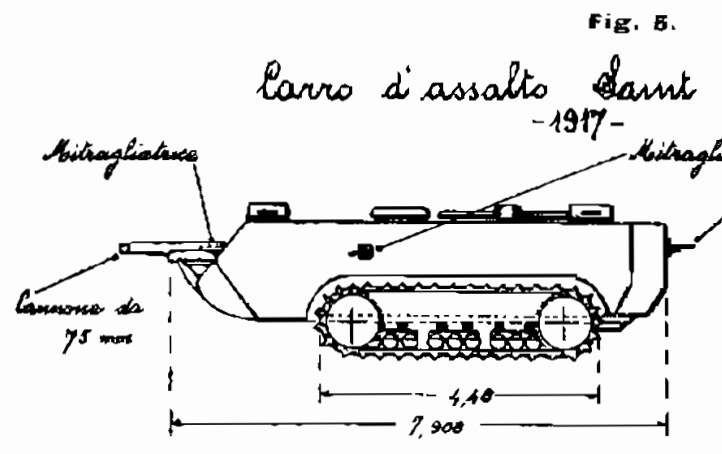
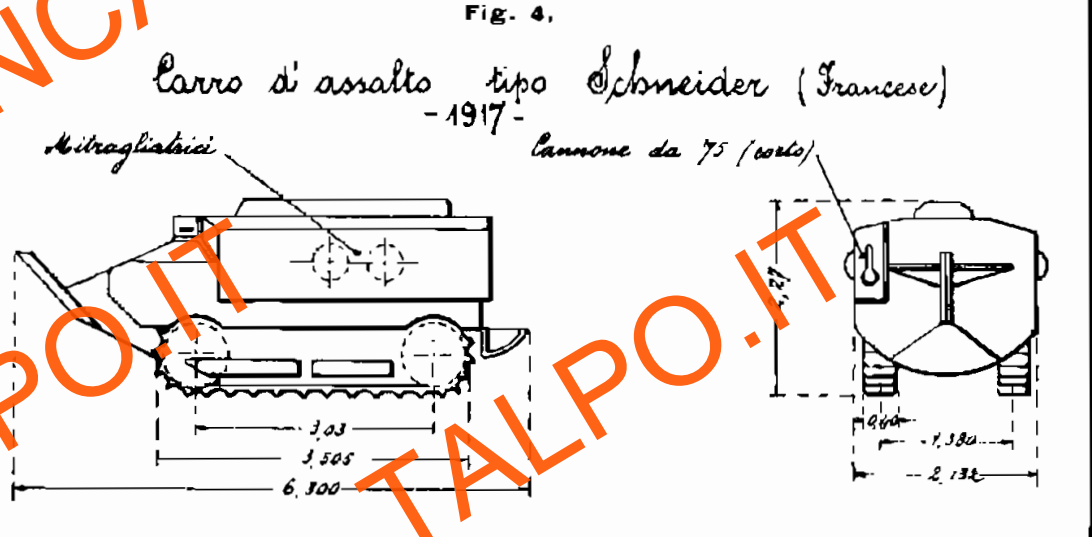
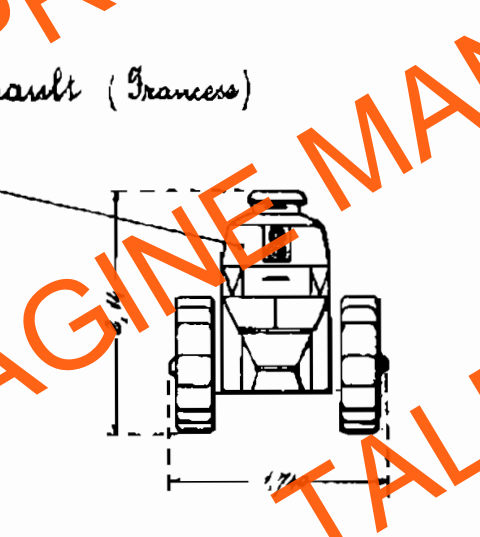
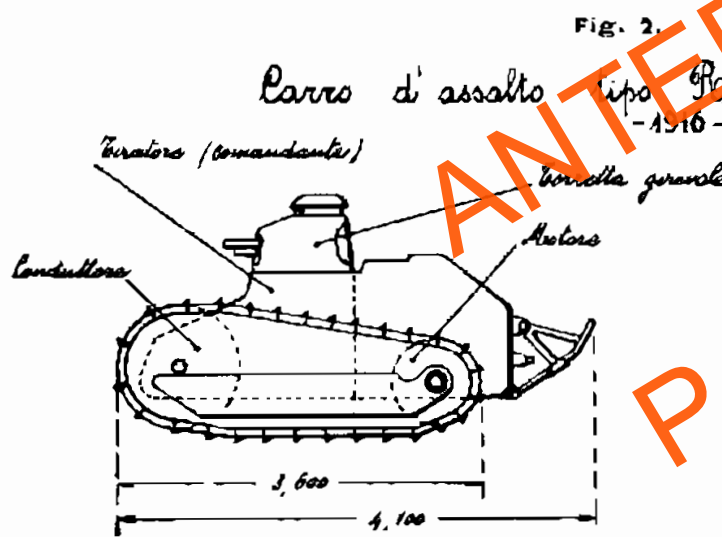
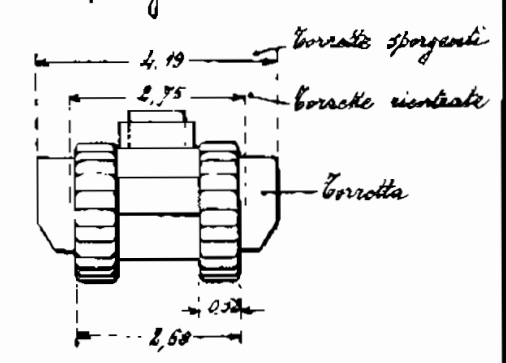
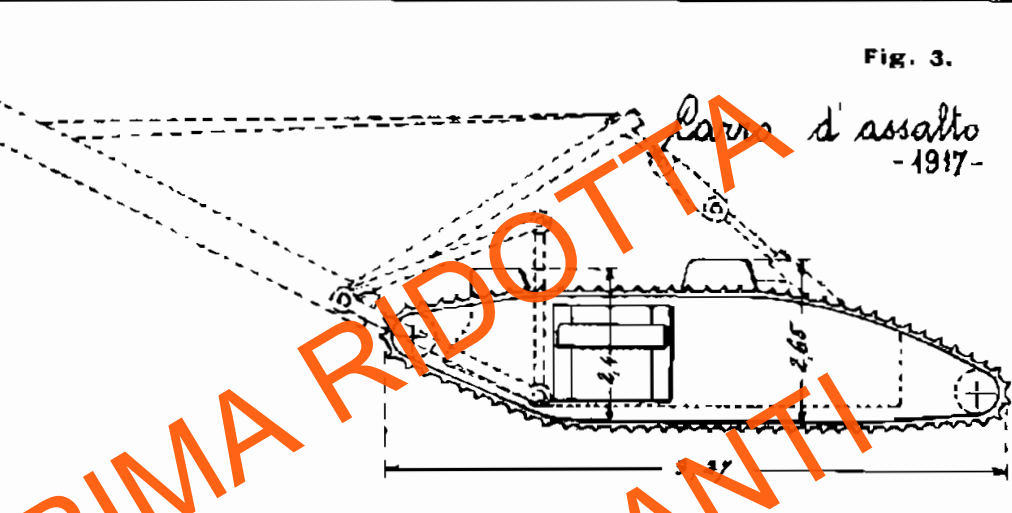
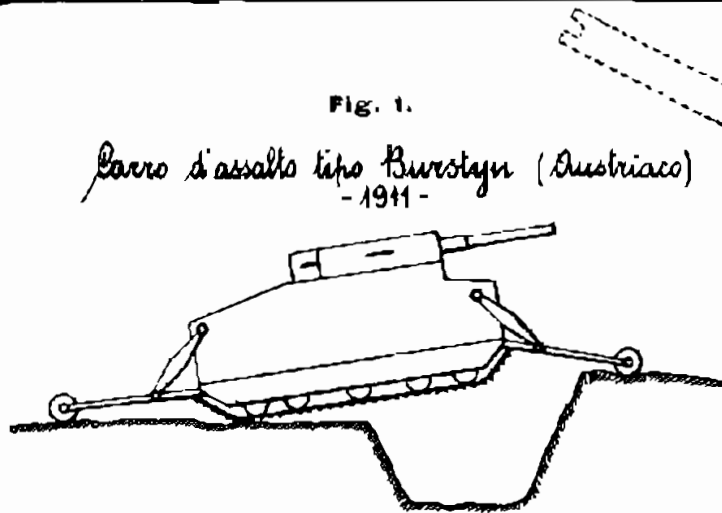

Fig. 630





ANTEPRIMA RIDOTTA  
PAGINE MANCANTI  
TALPO.IT



Fig. 7. Carro d'assalto Blfuende (tedesco) - 1917-

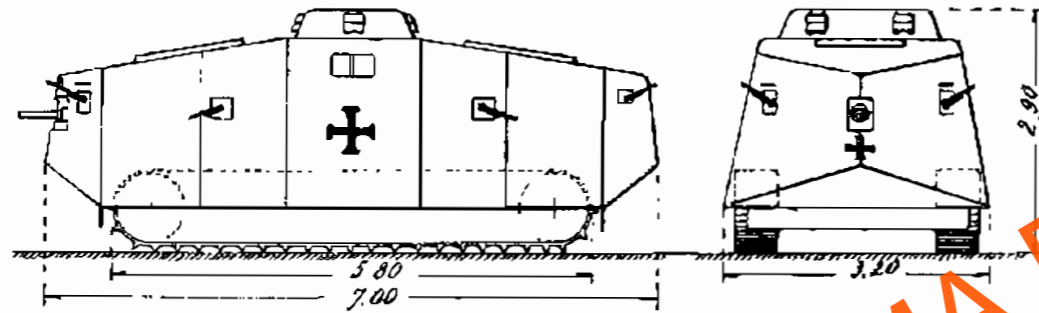

Fig. 10. Carro leggero con ruote anteriori (francese) - 1924-

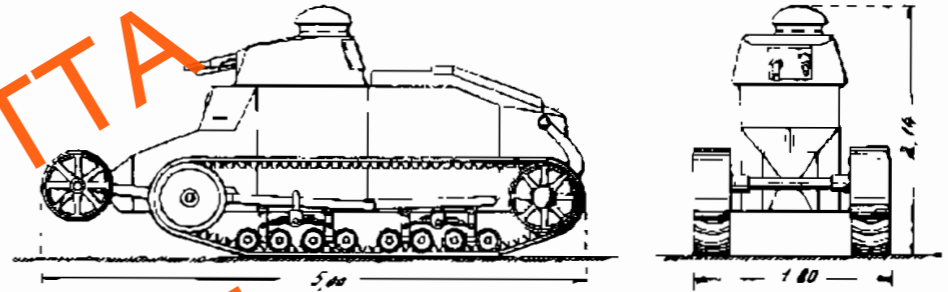

Fig. 8. Carro d'assalto Whippet (inglese) - 1917-

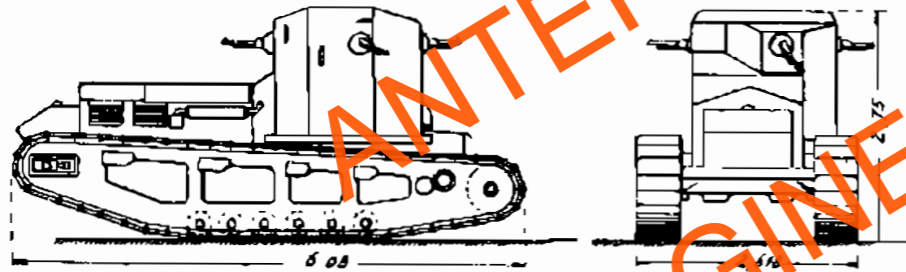

Fig. 11. Carro d'assalto Morris-Martel (monoposto) (inglese) - 1926-

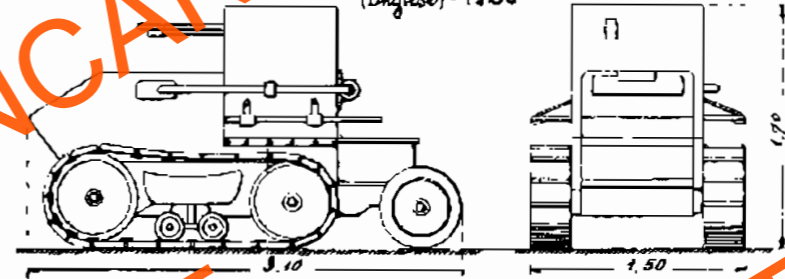

Fig. 12. Carro d'assalto Carden Loyd (monoposto) (inglese) - 1926-

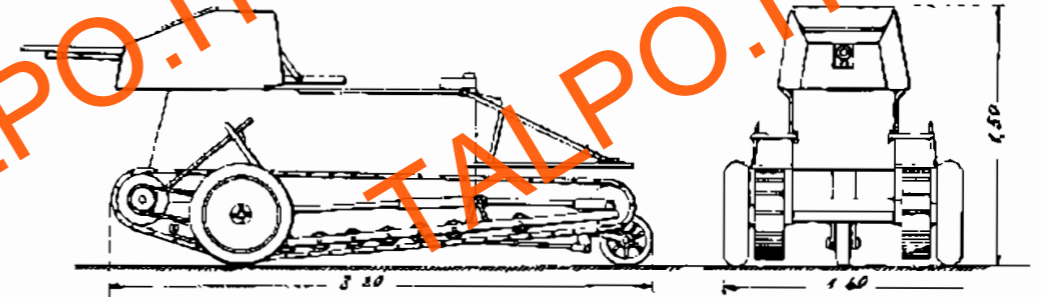

Fig. 9. Carro d'assalto M. 1922 (americano) - 1922-

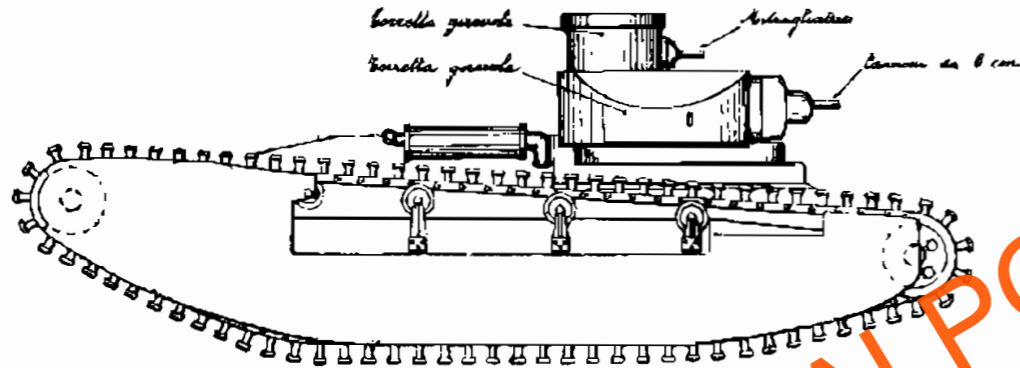
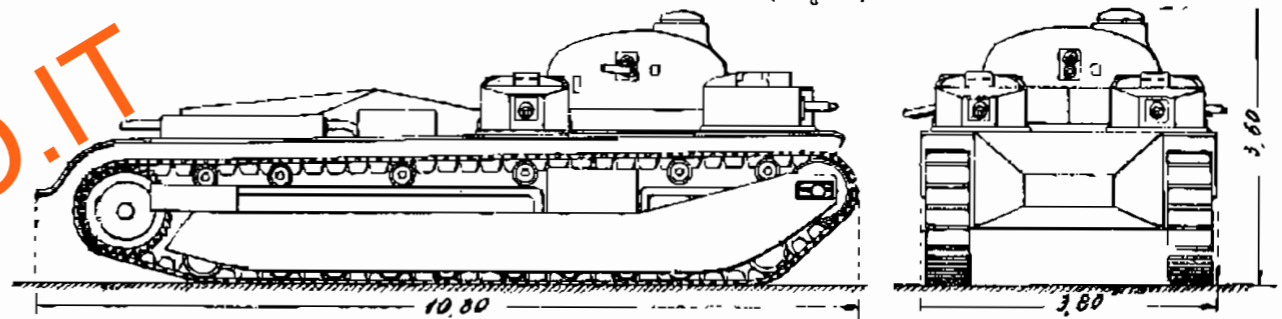

Fig. 13. Carro d'assalto Wickers pesante (inglese) - 1926-



ANTEPRIMA RIDOTTA  
PAGINE MANCANTI  
TALPO.IT

Fig. 14. Carro d'assalto Fiat (Russa) - 1924 -

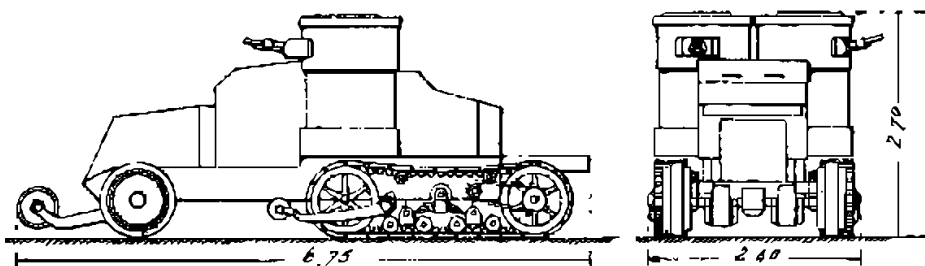

Fig. 18. Carro d'assalto Christie - anfibio (Americano) - 1923 -

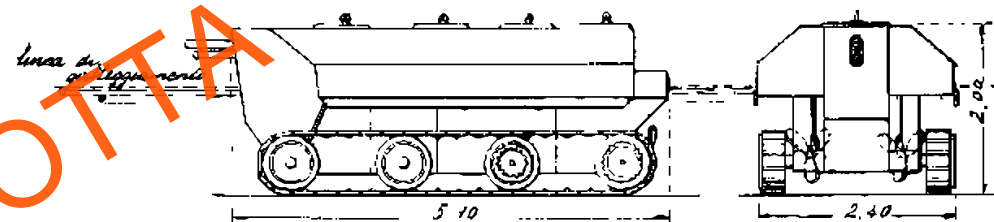

Fig. 15. Carro d'assalto M 21 (Svedese) - 1921 -

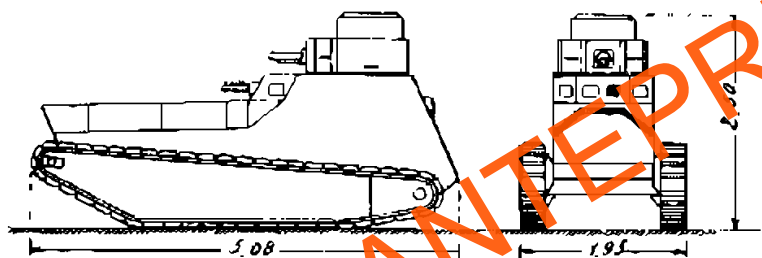

Fig. 19. Carro d'assalto Mark II medium (Inglese) - 1925 -

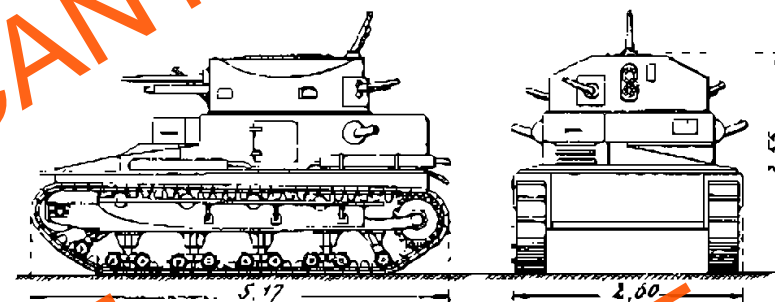

Fig. 16. Carro d'assalto KH 50 (Cecoslovacco) - 1925 -

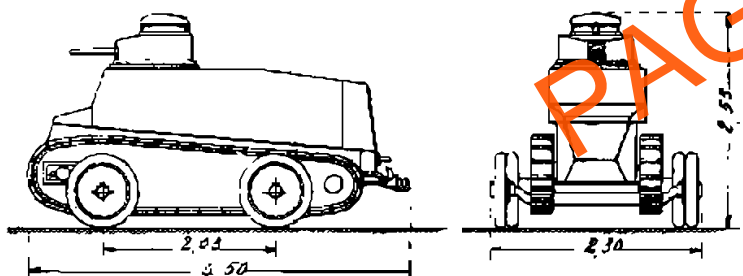

Fig. 17. Carro d'assalto 2 C (Francese) - 1922 -

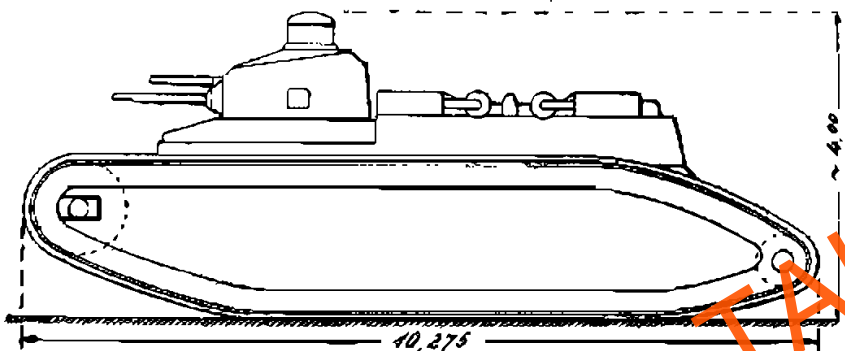

Fig. 20  
Sondi di fertilia

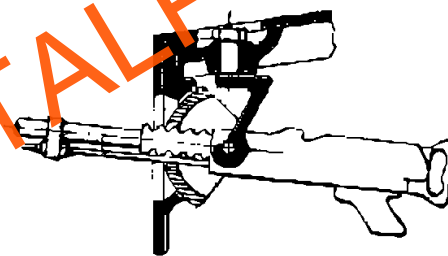
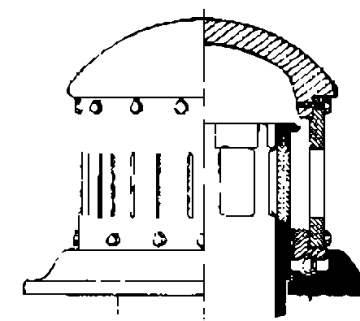
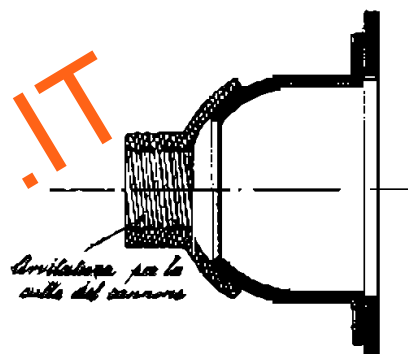

Fig. 21  
Stroboscopio



Arvitatore per la  
culle del cannone



a) Bomba lenticolare

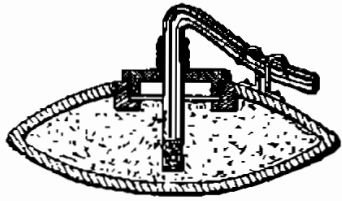
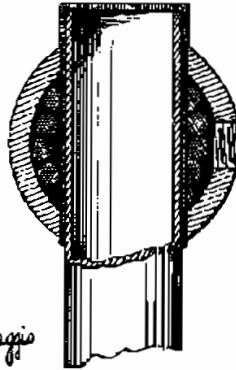

Fig. 1

c) Bomba difensiva sferica con manico (Austriaca)



d) Bomba Universale (Austriaca)

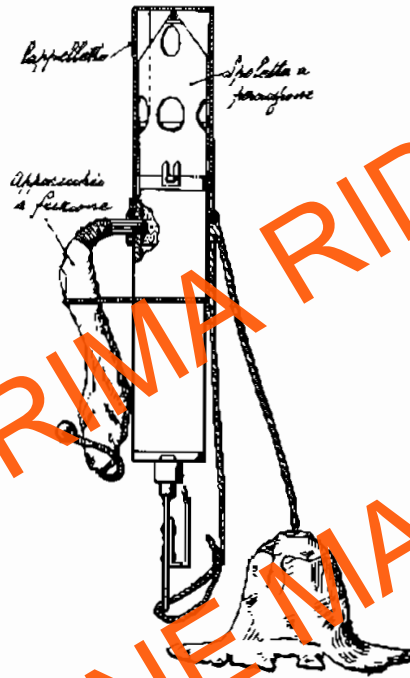

Fig. 2

Bomba offensiva



Bomba difensiva

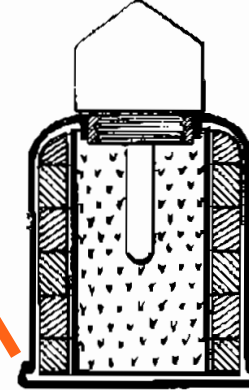
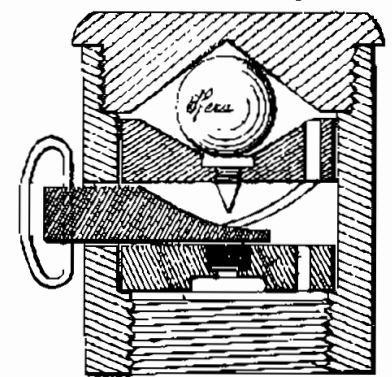
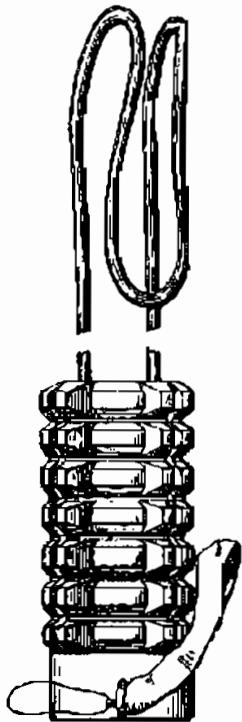

Fig. 7

Spalletto Allways



b) Bomba con manico di Londra



e) Bomba con indennaggio a gonnellino

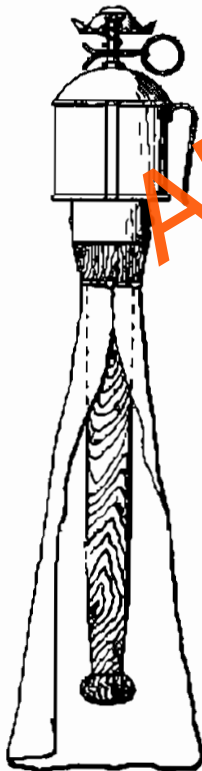
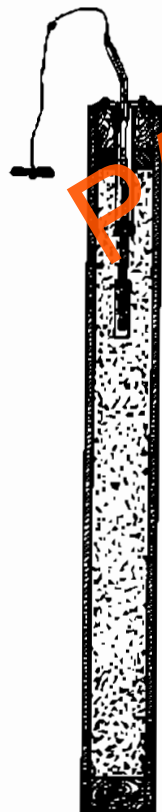

Fig. 4

Apparecchio



Bomba D.I.D.



Particolare dell'accensione per percussione

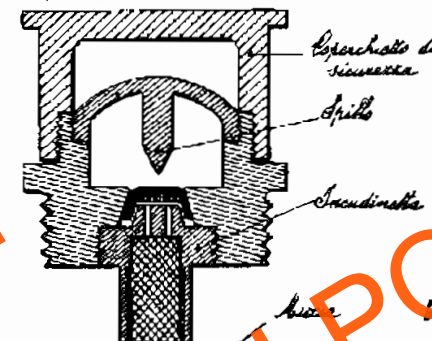

Fig. 8

Spalletto Mergon

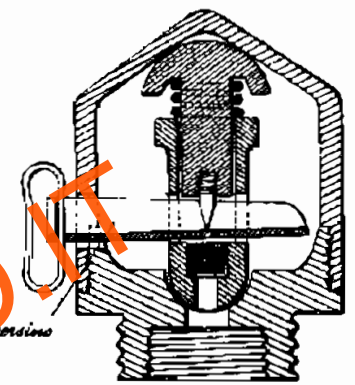
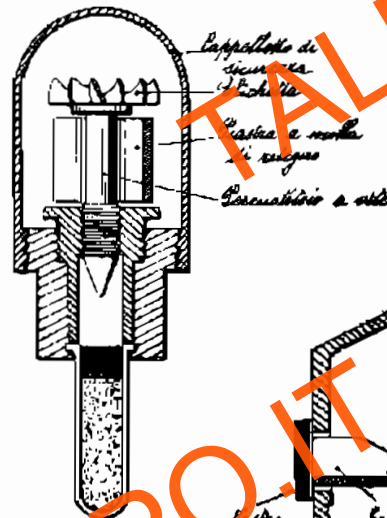

Fig. 6

Spalletto ad elica



Spalletto di sicurezza  
Pistola a molla  
di recupero  
Percussorio a vite

Fig. 9

Spalletto a nastro

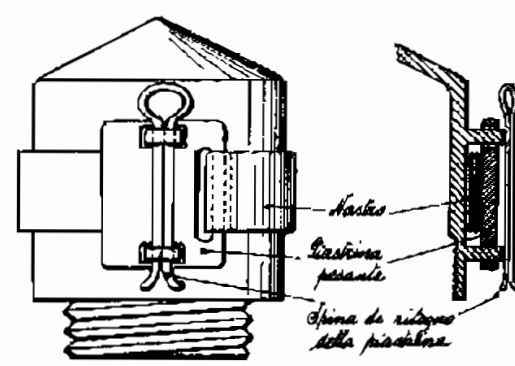

Arrotto  
Cassa fusa pesante  
Spina di ritorno della pistola

Fig. 10

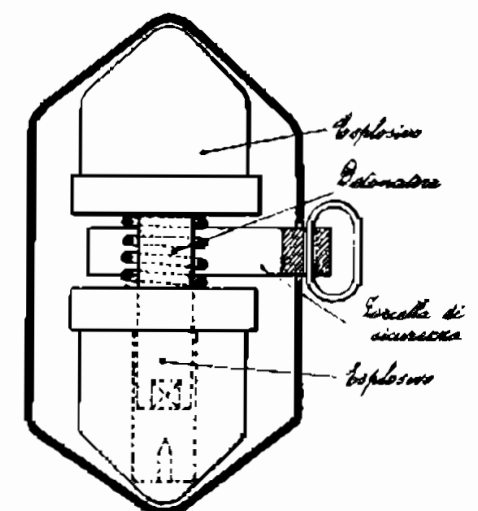

Spalletto  
Pulsatore  
Spalletto di sicurezza  
Spalletto

Fig. 3  
Bomba S.I.P.E.  
(difensiva) a rottura prestabilita

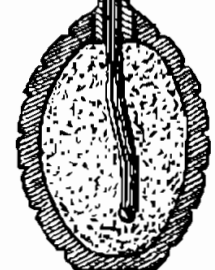

Fig. 11 Bomba da fucile Beraglia

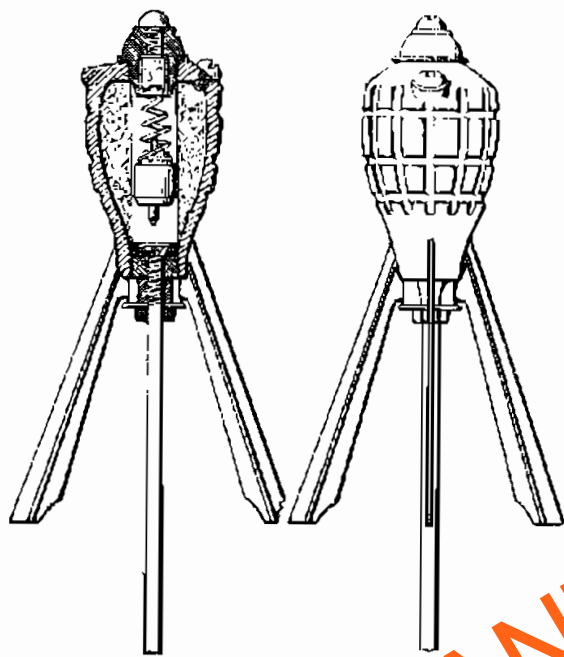

Fig. 12 Bomba da fucile austriaca



Fig. 16 Lanciabombe Gacelnor



Fig. 17 Lanciabombe bellica

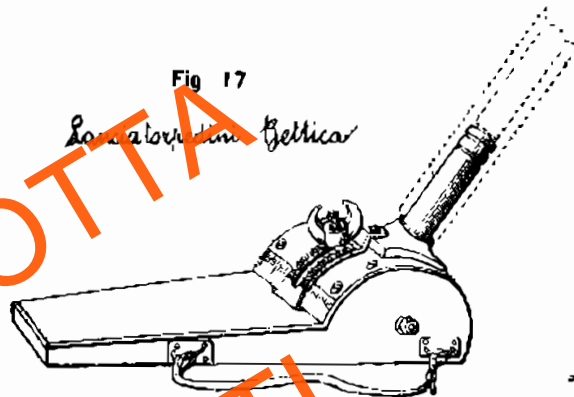

Fig. 18 Lanciabombe Chévenot

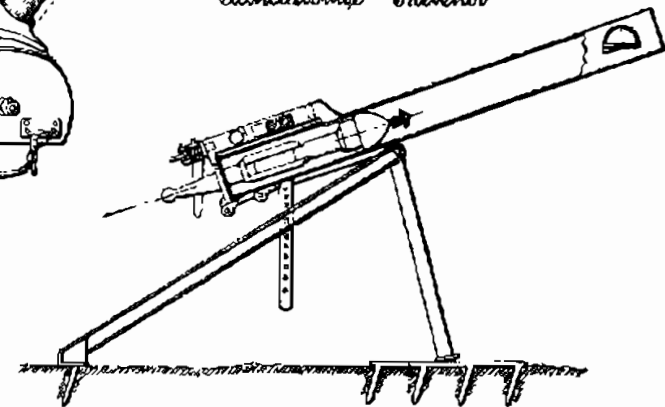

Fig. 19 Bombarda ad acetilene (tipo Hoaggura)

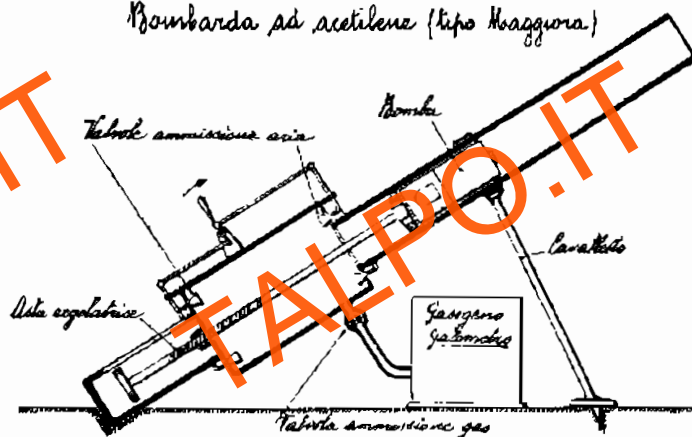

Fig. 21 Bomba Stokes (italiana)

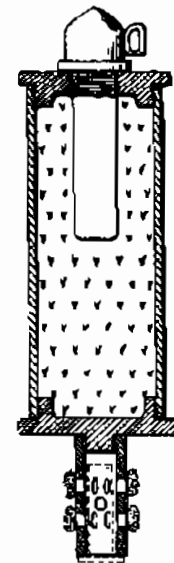

Fig. 13 Bomba da fucile Berlino

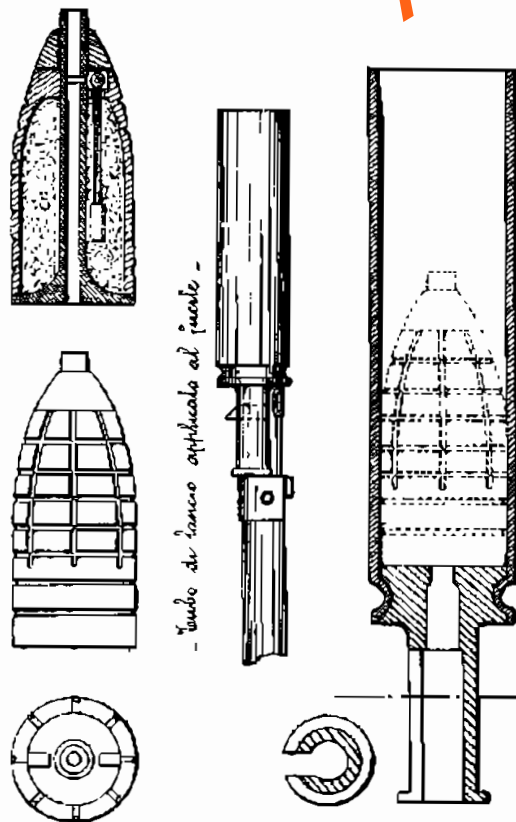

Fig. 14 Lanciabombe Minuciani

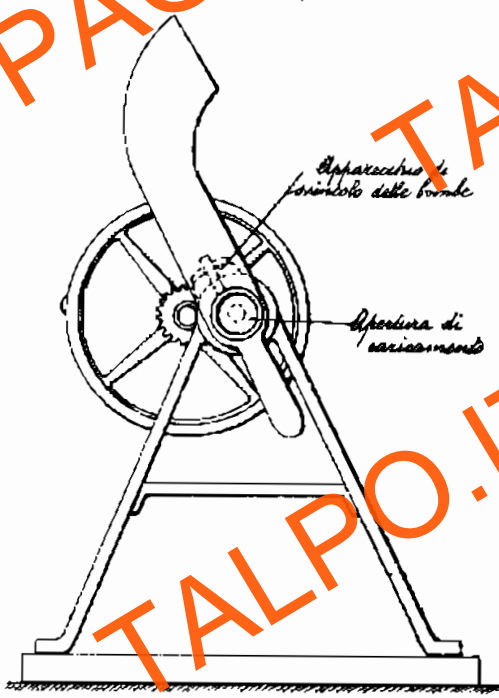
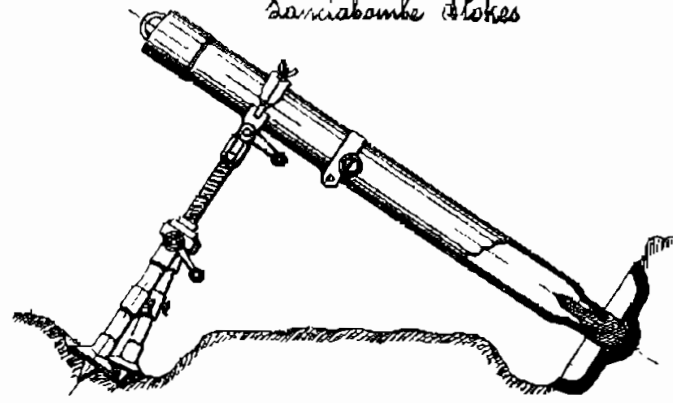

Fig. 15 Rachetta Lima



Fig. 20 Lanciabombe Stokes



ANTEPRIMA RIDOTTA  
PAGINE MANCANTI  
TALPO.IT

