

★ RESTRICTED

TECHNICAL MANUAL }  
No. 9-1940 }

WAR DEPARTMENT  
Washington, 15 July 1943

# LAND MINES

---

## CONTENTS

	Paragraph	Pages
SECTION I. Introduction .....	1	2
II. General .....	2-9	
III. Antitank mines and fuzes.....	10-15	
IV. Antipersonnel mines .....	16-22	23-36
V. Fuzes and firing mechanisms.....	23-28	37-48
VI. References .....	29-30	
INDEX .....		50-51

★ *Dissemination of restricted matter—The information contained in restricted documents and the essential characteristics of restricted materiel may be given to any person known to be in the service of the United States and to persons of undoubted loyalty and discretion who are cooperating in Government work, but will not be communicated to the public or to the press except by authorized military public relations agencies. (See also paragraph 18 b, AR 380-5, 28 September 1942.)*

\* Supersedes TB 1940-1, dated 24 September 1942; TB 1940-2, dated 24 September 1942; TB 1940-3, dated 8 October 1942; TB 1900-10, dated 5 January 1943; TM 9-1900, paragraphs 65 to 70; TC 12, 1942; and TC 75, 1942, paragraphs 5, 7, 8, and 9.

**LAND MINES**

**Section I**

**INTRODUCTION**

Paragraph

Purpose and scope ..... 1

**I. PURPOSE AND SCOPE.**

a. The purpose of this manual is to impart information of a technical nature concerning land mines and related items, such as may be necessary for their intelligent care, handling, and use.

b. This manual describes:

- (1) Antitank mines.
- (2) Antipersonnel mines.
- (3) Bangalore torpedoes.
- (4) Demolition materials.
- (5) Fuzes and firing mechanism.

c. The information covers:

- (1) Identification.
- (2) Care, handling, and preservation.
- (3) Fuzing and unfuzing.
- (4) Authorized assembly and disassembly.
- (5) Packing and marking.

*& see C1,*

MEMO  
dimensione ridotta

Section II

GENERAL

	Paragraph
Description .....	2
Classification .....	3
Identification .....	4
Care and precautions in handling .....	5
Storage and preservation .....	6
Destruction of unserviceable material and duds .....	7
Packing and marking for shipment .....	8
Field report of accidents .....	9

**2. DESCRIPTION.**

a. All types of land mines consist of a charge of high explosive and a device for detonating this charge under the proper conditions. In general, land mines are of the trap type; they rely on some action of the enemy for initiation. Some types are of complicated design, as the bounding mine which projects a shell 6 to 8 feet above the ground and explodes it there. Most types are simple, consisting only of a container of high explosive and a firing mechanism.

**3. CLASSIFICATION.**

a. Land mines are classified according to the use for which they are designed as antitank and antipersonnel. However, either type may, on occasion, be used for the other and both types may be used for demolitions, just as either type may be improvised from demolition materials.

b. Antitank mines are also classified as high-explosive, practice, or dummy.

**4. IDENTIFICATION.**

a. **General.** Ammunition is identified by means of the painting and marking on the item itself and all containers. Complete identification is furnished by:

(1) Standard nomenclature which includes type, size, and model.

(2) Lot number, which includes manufacturer's lot number, manufacturer's initials or symbol, and date of loading.

b. **Standard Nomenclature.** Standard nomenclature is established in order that each item supplied may be specifically identified by name. Its use, for all purposes of record, is mandatory except as noted in subparagraph c, below.

c. **Ammunition Identification Code.** To facilitate reporting, requisitioning, and record keeping in the field, each complete round and each item of issue is assigned a five-character code symbol.

## LAND MINES

These symbols and information concerning their use may be found in Standard Nomenclature Lists and OFSB 3-14.

d. **Mark or Model.** To distinguish a particular design, a model number is assigned when the design is adopted. This designation becomes an essential part of the nomenclature of the item. It consists of the letter "M" followed by an Arabic numeral. Modifications of the original model are indicated by adding the letter "A" and the appropriate Arabic numeral to the model designation. Formerly, the word "Mark" was used. This was abbreviated "Mk." and followed by a Roman numeral.

e. **Ammunition Lot Numbers.** When ammunition is manufactured, an ammunition lot number is assigned in accordance with pertinent specifications. The lot number is marked or stamped on every item (unless the item is too small) and on all containers of the ammunition. Its use is required for all purposes of record, including reports on condition, function or accidents.

f. **Painting.** Ammunition is painted to prevent rust, to provide, by the color, an aid to concealment, and for identification as to type. Service land mines are painted lusterless olive-drab with marking in black. However, where it will not affect the concealment qualities, there is an area painted in accordance with the ammunition identification color scheme: yellow, high-explosive; blue, practice; black, dummy or drill.

g. **Marking.** When the size of the item permits, each item of ammunition is marked with the type, size, model, and lot number of the item. Each container is marked with the same information.

## 5. CARE AND PRECAUTIONS IN HANDLING.

a. Ammunition should be protected against moisture, heat, and shock.

b. Ammunition is packed to withstand all ordinary conditions encountered in handling and shipping. Items that are not waterproof are packed in moisture resistant containers. Such containers should not be opened until the ammunition is about to be used or prepared for use. Items unpacked but not used should be repacked and the containers sealed. Such items should be used first in subsequent operations in order that stocks of opened packings may be kept to a minimum.

c. Damaged packings should be repaired or the items transferred to new packings. Care should be exercised to see that all original markings are reproduced on the new parts of the container.

d. Mines planted in wet surroundings should be waterproofed by treating the joints with grease, wax, cement, or sealing compound.

## GENERAL

e. Ammunition should be protected against sources of excessive heat, including the direct rays of the sun. Boxes stored in the open should be covered by a paulin and piled so that there will be free circulation of air throughout the pile.

f. Fuzes, primers, and detonators are especially sensitive to heat and shock.

g. Boxes of ammunition should not be dropped, dragged, or tumbled.

h. Boxes should not be opened in a magazine nor within 100 feet of a store of explosives. Safety tools should be used in unpacking and repacking operations. Safety tools are those made of copper, wood, or other material incapable of producing sparks when struck.

i. No attempt will be made to fuze an item of ammunition closer than 100 feet to a magazine or other such store of explosives or ammunitions.

j. No disassembly of ammunition or components thereof will be permitted except as specifically authorized.

k. Safety pins, safety forks, and other safety devices are designed for the protection of planting personnel. They should be left in place until the last practicable moment before leaving and then removed. In picking up mines, they should be replaced first.

l. Care will be exercised to see that fuze cavities or detonator wells are clear of obstruction and free of foreign material before attempting to assemble the fuze or detonator.

m. Blasting caps, detonators, and fuzes with detonator assembled should be protected from shock, heat, and friction. By "shock" is meant such as is given by detonators knocking together when carried loose in the pocket or when dropped from any height whatever; by "heat," such as prolonged exposure to the direct rays of the sun; by "friction," any abnormal friction such as sliding across a table or being forced into a tight or obstructed well.

## 6. STORAGE AND PRESERVATION.

a. Explosives and ammunition should be stored in buildings designed, designated, and isolated for the specific purpose. Explosives and ammunition should not be stored in buildings which are used for other purposes, such as basements or attics of barracks, company supply rooms, or general storehouses. When specially constructed magazines are not available, the buildings used must afford good protection against moisture and dampness and have means for adequate ventilation. They must be floored with approved material and may not be heated by open fires or stoves.

b. Boxes, cases, and other containers of ammunition should be clean and dry before being stored. Damaged containers will be re-

## LAND MINES

paired or replaced before storing, but the repairs or change of container will not take place in or within 100 feet of a magazine containing explosives. Powder dust or particles of explosive material from broken containers will be carefully taken up as soon as spilled. All work will be suspended until this has been done. Ammunition containers should not be opened in a magazine nor should they be stored after having been opened unless they have been closed securely. No nails or tacks will be driven into a container of explosives or ammunition. Cases should be handled with care. Cases should not be dragged across the floor in magazines as this practice has resulted in starting fires where there was powder dust present.

c. Loose rounds or components will not be kept in a magazine. No empty container, no excess dunnage nor tools, should be permitted to remain in a magazine. No oily rags, paint, turpentine, etc., will be left in a magazine containing ammunition or explosives.

d. Ammunition should be piled by lot numbers in stable piles which are so arranged that the individual containers are accessible for inspection and offer no obstacle to the free circulation of air. The tops of ammunition piles will be below the level of the eaves to avoid the heated space directly beneath the roof. The bottom layer should be raised off the floor about 2 inches. Dunnage should be level; if necessary, shims or wedges should be used. Stacks should not be so high that ammunition or its containers in the lower layers will be crushed or deformed. Partly filled boxes should be fastened securely, marked, and kept on the top of the pile.

e. Magazines should be built on well drained ground.

f. It is essential that explosives and ammunition be segregated in an area specifically set aside for their exclusive storage. This area need not be large, but it is important that it be segregated from inhabited buildings, public highways, and railroads. Individual magazines must be separated by distances adequate to prevent propagation of an explosion from one to another. Such distances are given in TM 9-1900.

g. Vegetation should be controlled and dry leaves, grass, and rubbish removed from the magazine area and burned.

h. Accumulation of trash, empty boxes, scrap lumber, or any such inflammable material should not be permitted.

i. A 50-foot firebreak should be established around each above-ground magazine.

j. Smoking, the carrying of matches, and the use of lights other than approved electric lights in magazines or explosives storage areas, are forbidden.

## GENERAL

k. Interiors of magazines should be clean. Paint, oils, gasoline, waste, rags, and other inflammable material should not be left in magazines.

l. Except when they are issued in one packing, mines and fuzes will not be stored in the same magazine. This applies to the detonating element of fuzes such as detonators, blasting caps, and the like, and not to metal parts of fuzes or firing mechanisms when the detonating element is not assembled thereto.

### 7. DESTRUCTION OF UNSERVICEABLE MATERIAL AND DUDS.

a. **General.** Unserviceable material and duds will be destroyed only by authorized and experienced personnel. Safety precautions such as those laid down in TM 9-1900 and in Ordnance Safety Manual OO No. 7224, will be observed.

b. **Burning.** Unconfined explosives such as demolition blocks may be destroyed by spreading out thin on a layer of combustible material and burning. Small components may be burned in a covered trench or pit by preparing the fire, placing a quantity of the item to be destroyed on the pile, and igniting from a distance by such means as a train of excelsior. Larger items such as the FUZE, antitank mine, M1, may be burned in a covered pit by feeding one at a time down a baffled chute from behind a barricade.

#### c. Detonation.

(1) Larger items will be destroyed by detonation at safe distances from buildings, inhabited areas, and magazine areas.

(2) Thin-walled mines, such as the antitank mine or bangalore torpedo, will need only one demolition block to detonate a pile but, because the thin-walled mines contain such a large percentage of explosive, care must be exercised to limit the number destroyed at a blast.

(3) Thick-walled mines, such as the antipersonnel mines, will need correspondingly more explosive and greater barricading to limit fragments.

(4) Blasting caps inserted in the fuze cavity or detonator well may be used to destroy an item, instead of using the cap and a block of demolition explosive.

d. **Duds.** Any land mine which failed to explode when its fuze or firing mechanism was operated and any unexploded mine that shows signs of having been operated (such as an antitank mine with vehicle tracks over its location or a mine with a half-pulled detonator wire) will be regarded as a dud. No attempt will be made to disarm, unfuze, or take up a dud. It will be destroyed in place with explosive.

**LAND MINES**

**8. PACKING AND MARKING FOR SHIPMENT.**

a. Packing data for land mines and their components are given in Table I.

b. In addition to nomenclature and lot number, packings offered for shipment are marked with the Interstate Commerce Commission name or classification of the article, the names and addresses of consignor and consignee, volume and weight, and the code symbol.

*see C1*

**TABLE I**

Item	Quantity	Dimensions (in.)	Sq. Ft.	Ca. Weight (lb.)	
BLOCK, demolition, M2 and M3	16	21 <sup>11</sup> / <sub>16</sub> x 14 <sup>15</sup> / <sub>16</sub> x 7 <sup>11</sup> / <sub>32</sub>	2.16	1.32	62
BLOCKS, demolition, chain, M1	2	21 <sup>11</sup> / <sub>16</sub> x 14 <sup>5</sup> / <sub>16</sub> x 7 <sup>11</sup> / <sub>32</sub>	2.16	1.32	62
CAP, blasting, tetryl, electric	500	22 x 15 x 9 <sup>1</sup> / <sub>2</sub>	2.29	1.81	54
CAP, blasting, tetryl, electric	5,000	19 x 16 x 8	2.11	1.40	65
EXPLOSIVE, nitrostarch, rectangular	50 pkg.	Quantities and dimensions may vary with different manufacturers			
EXPLOSIVE, TNT, rectangular	108	17 <sup>3</sup> / <sub>4</sub> x 12 x 9	1.48	1.11	
FUZE, mine, antitank, H.E., M1A1	100	27 <sup>5</sup> / <sub>8</sub> x 14 <sup>3</sup> / <sub>4</sub> x 8 <sup>23</sup> / <sub>32</sub>	2.83	2.06	96
FUZE, mine, antitank, practice, M1	100	27 <sup>5</sup> / <sub>8</sub> x 14 <sup>3</sup> / <sub>4</sub> x 8 <sup>23</sup> / <sub>32</sub>	2.83	2.06	162
MINE, antipersonnel, M2 and M2A1	10	32 x 13 <sup>3</sup> / <sub>16</sub> x 9 <sup>15</sup> / <sub>32</sub>	2.93	2.31	93
MINE, antipersonnel, M3	6	17 <sup>7</sup> / <sub>8</sub> x 8 <sup>11</sup> / <sub>16</sub> x 9 <sup>1</sup> / <sub>32</sub>	1.08	.81	72
MINE, antitank, H.E., M1	5	26 <sup>1</sup> / <sub>8</sub> x 9 <sup>3</sup> / <sub>4</sub> x 10 <sup>17</sup> / <sub>32</sub>	1.77	1.55	68
MINE, antitank, H.E., M1A1	5	26 <sup>1</sup> / <sub>8</sub> x 9 <sup>3</sup> / <sub>4</sub> x 10 <sup>17</sup> / <sub>32</sub>	1.77	1.55	71
MINE, antitank, H.E., M4	5	26 <sup>1</sup> / <sub>8</sub> x 10 x 10 <sup>25</sup> / <sub>32</sub>	1.8	1.6	68
MINE, antitank, H.E., M5	4	26 <sup>7</sup> / <sub>8</sub> x 11 <sup>3</sup> / <sub>8</sub> x 12 <sup>1</sup> / <sub>8</sub>	2.54	2.58	78
MINE, antitank, practice, M1	5	26 <sup>1</sup> / <sub>8</sub> x 9 <sup>3</sup> / <sub>4</sub> x 10 <sup>17</sup> / <sub>32</sub>	1.77	1.55	64
MINE, antitank, practice, M1B1	5	26 <sup>1</sup> / <sub>8</sub> x 10 x 10 <sup>25</sup> / <sub>32</sub>	1.8	1.6	37
TORPEDO, bangalore, M1	10	63 <sup>3</sup> / <sub>8</sub> x 15 <sup>7</sup> / <sub>8</sub> x 5 <sup>3</sup> / <sub>8</sub>	6.99	3.13	168



Section III

ANTITANK MINES AND FUZES

	Paragraph
General .....	10
Antitank mines .....	11
Practice antitank mines .....	12
Dummy antitank mines .....	13
Antitank mine fuzes .....	14
MINE, antitank, nonmetallic, H.E., M5, and FUZE, mine, anti-tank, chemical, M5 .....	15

10. GENERAL.

a. An antitank mine is any charge of explosive concealed or laid where it may be passed over and exploded by vehicle. In addition to the standardized types described below, antitank mines can be improvised from bangalore torpedoes (par. 19) and demolition blocks (pars. 20, 21, and 22).

11. ANITANK MINES.

a. General. This type of mine is shown with principal dimensions and marking in figures 1, 2, 3, and 4. The complete round consists of three components: the mine body, the spider, and the fuze.

b. Description. The mine body is a squat cylindrical container of light steel, filled with high explosive. The bottom is plain and the side has a carrying handle attached. The top extends beyond the side to form a grooved flange for the attachment of the spider. In the center of the top there is an opening for the fuze cup and to the side there is a capped filling hole. The fuze is described in paragraph 14. The spider is in the shape of a wheel and has four hooks attached to the rim for assembling the spider to the flange on the mine body. When assembled, the hub of the spider rests on the striker head of the fuze. As shipped, the spider is nested to the bottom of the mine body.

c. Fuzing. The following steps are required to assemble the complete round:

(1) Remove the spider from the bottom of the body.

(2) Insert fuze in fuze cup. Push the fuze down until it latches. When thus assembled, the upper surface of the fuze body is flush with the upper surface of the mine.

see c/ NOTE: Before inserting fuze, be sure that the fuze cup is clear, that is, no foreign matter present; in the Mine M1A1 or M4, be sure the booster is in the bottom of the fuze cup.

(3) Assemble spider. To assemble the spider, aline two adjacent hooks with the two notches in the flange of the body. Engage the

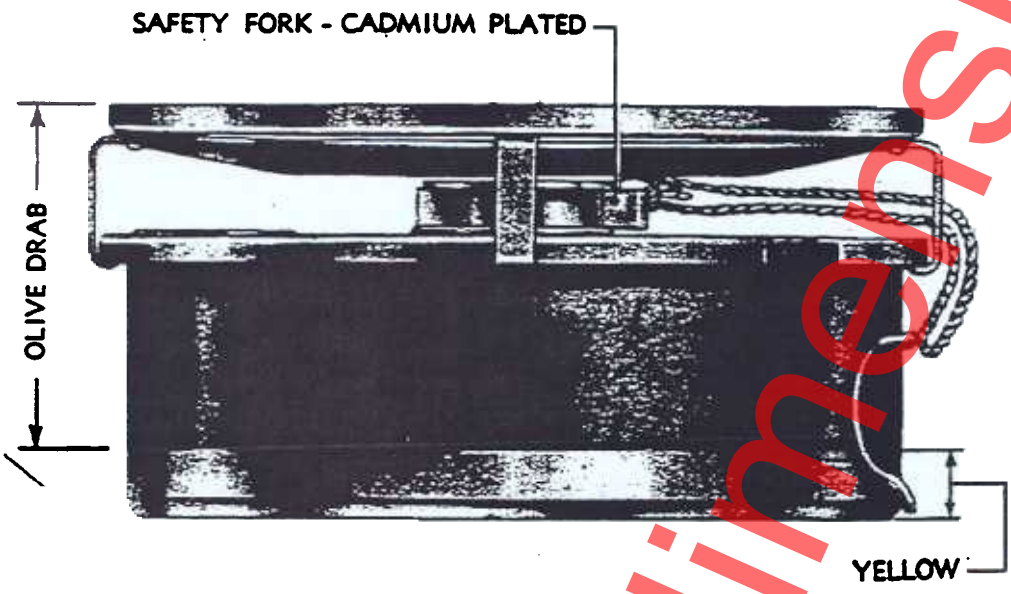
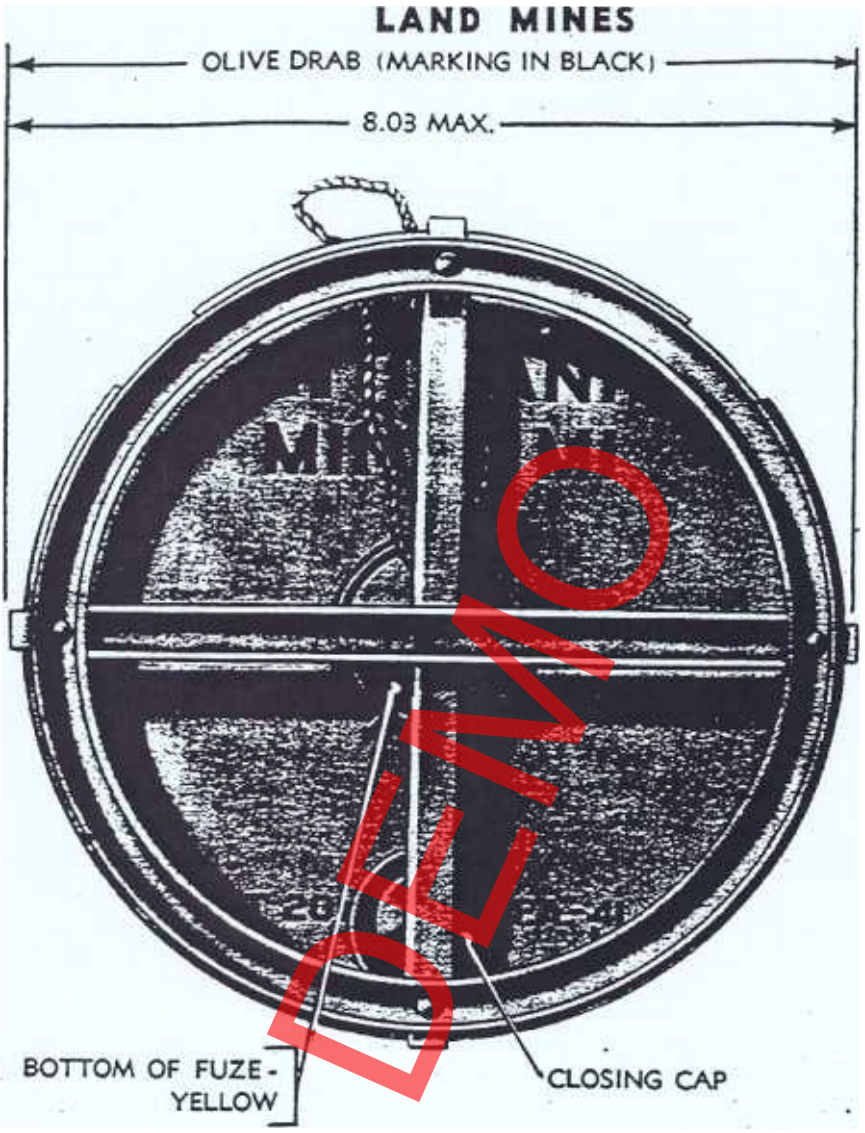

**Figure 1 MINE, Antitank, H.E., M1, Fuzed**

RA PD 53880A

10

OLIMENSIONE ridotta

### ANTITANK MINES AND FUZES

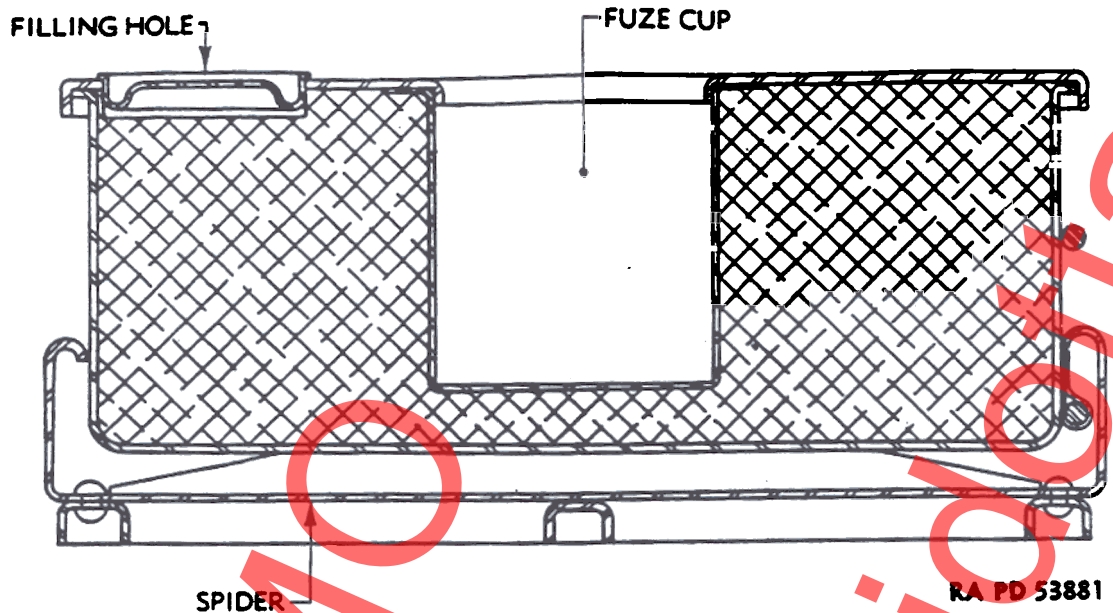

*Risk* **Figure 2 — MINE, Antitank, H.E., M1, as Shipped**

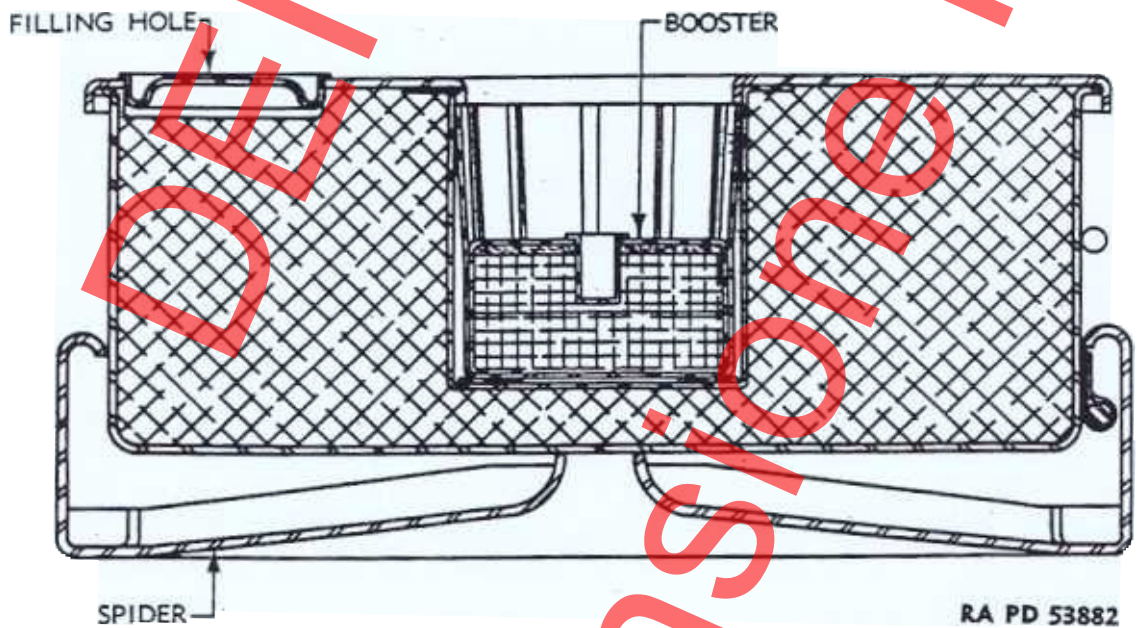

**Figure 3 — MINE, Antitank, H.E., M1A1, as Shipped**

other two hooks over the flange on the body; next press the first two hooks through the notches; then rotate the spider approximately one-eighth turn in either direction to secure the spider to the body.

(4) Plant mine.

*use* (5) Pull safety fork, thereby arming fuze. If the mine is buried spider down, the safety fork will have to be removed before the mine is buried. The safety fork should be left beside the mine attached to its cord, never between the body and the spider.

LAND MINES

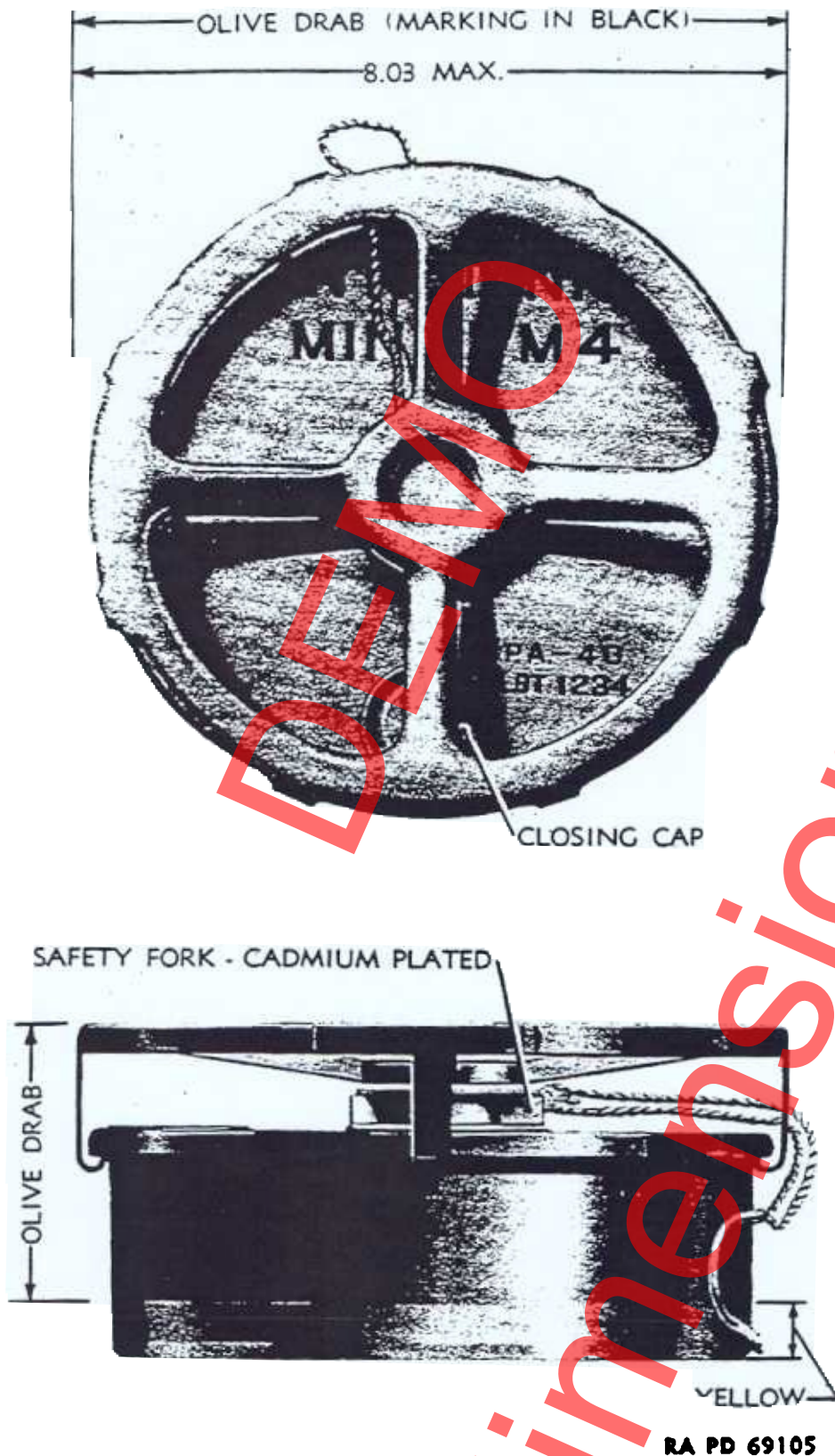

Figure 4 MINE, Antitank, H.E., M4.

# ANTITANK MINES AND FUZES

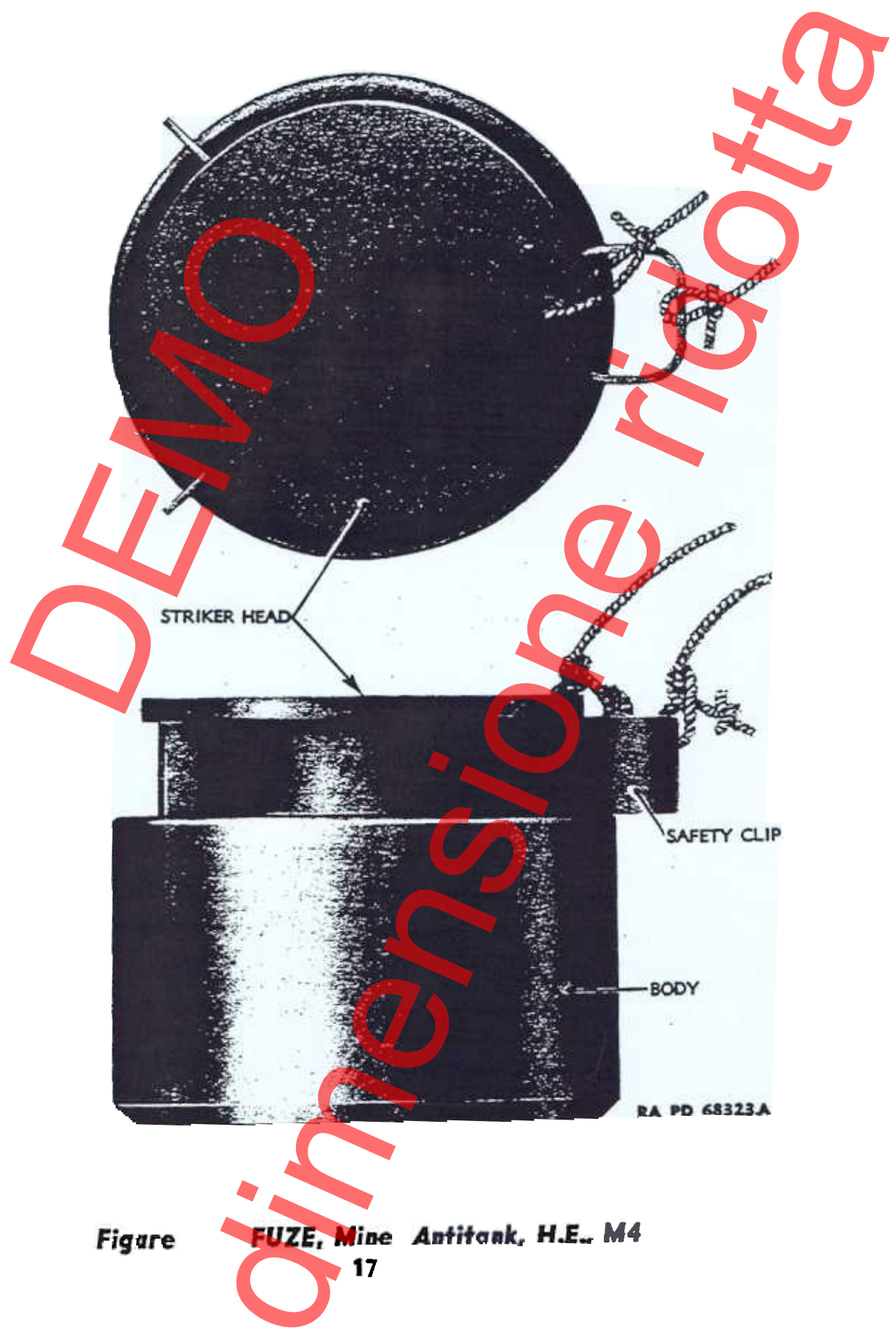
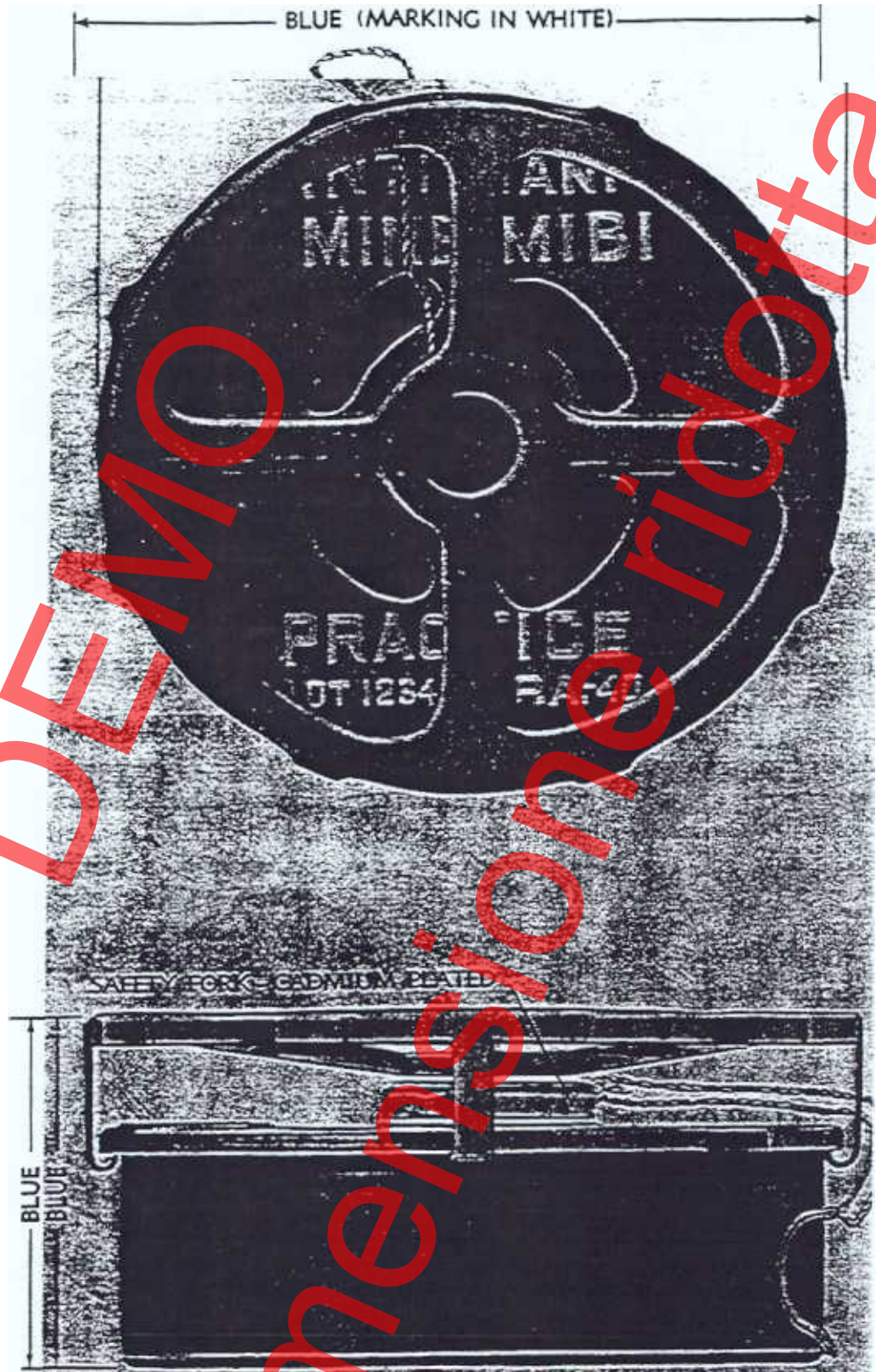

Figure 17 **FUZE, Mine Antitank, H.E., M4**

# ANTITANK MINES AND FUZES



RA PD 69104

Figure 8 MINE, Antitank, Practice, M1B1

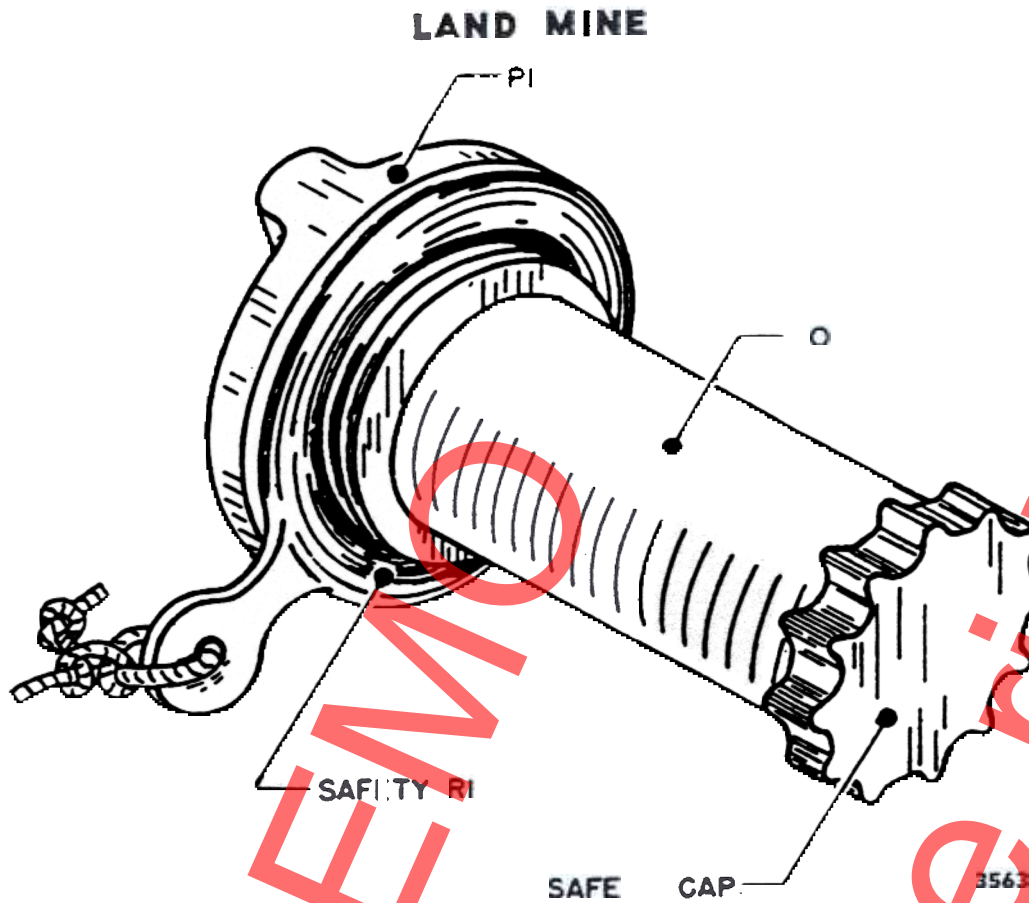

**Figure 9 FUZE, Mine Antitank, Chemical M5**

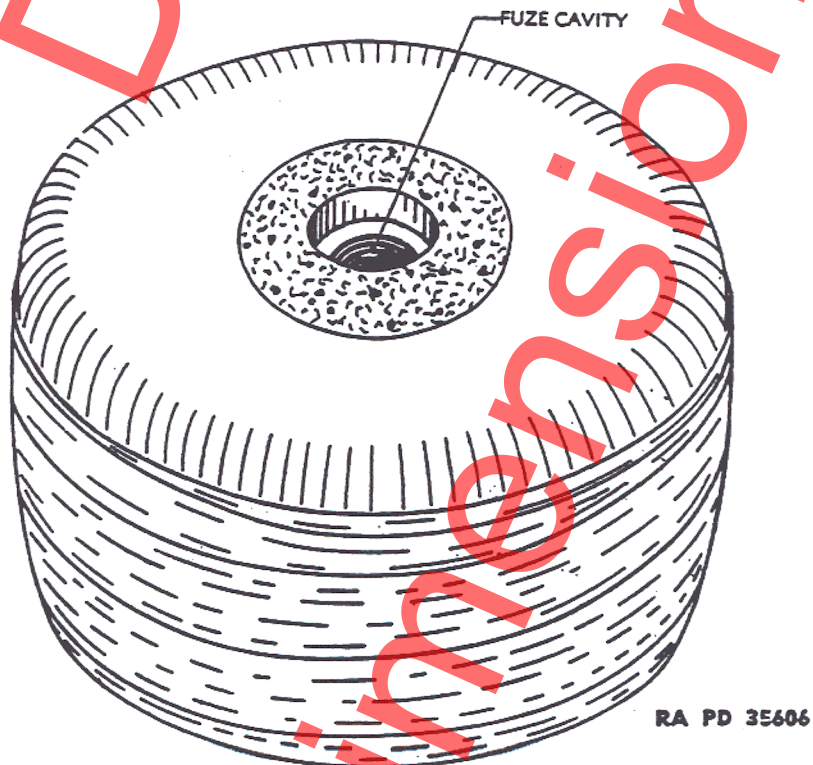

**Figure 1 MINE, Antitank, Nonmetallic, H.E. M5**

# LAND MINES



Figure 11 MINE, Antipersonnel, M2



# ANTIPERSONNEL MINES

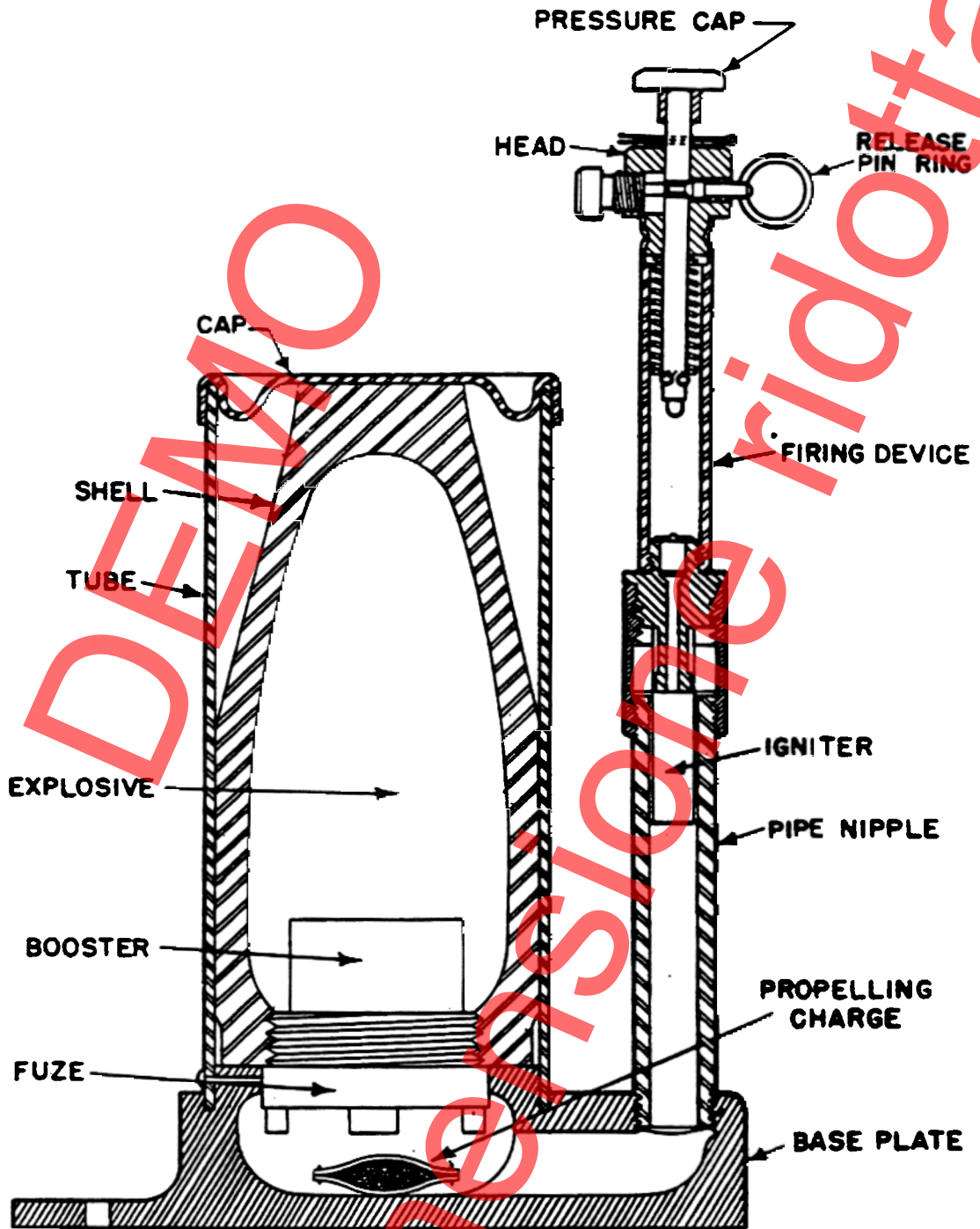

RA PD 49598C

Figure 12 — MINE, Antipersonnel, M2A1

## LAND MINES

agonal cap. FUZE, mine, antipersonnel, M2, is shipped separately in a tube, in the same box with the mine.

(2) The fuze issued with this mine consists of the Combination Firing Device M1 (par. 24) with an igniter cap attached. The base and igniter are assembled to the mine and the firing pin assembly is supplied, disassembled, in the same carton. It is a simple type firing mechanism containing a spring-loaded firing pin. It may be fired by means of a trip wire connected to the release pin ring or by pressure applied to the pressure cap (fig. 11). A pressure of 20 to 40 pounds on the pressure cap or tension of 3 to 6 pounds on the release pin will cause release of the firing pin and detonation of the mine. Lengths of wire packed with the mines are for connecting to the release pin ring and making tripping devices. The wire supplied with some mines is olive-drab; that supplied with others is sand colored.

**c. Operation.** To assemble the mine, remove the hexagonal cap from the primer and, after making sure that the locking screw and safety pin are in place, screw the firing pin assembly onto the primer.

(1) **To PLANT OR PREPARE FOR ACTION** (par. 24 c).

(a) Be sure the locking screw and safety pin are in place.

(b) Place the mine on a firm foundation.

(c) Remove the hexagonal cap from the primer and screw on the firing pin assembly.

(d) Attach trip wire or install the pressure trip on the pressure cap.

(e) Check to see that the trip wire is not too tight or that there is not too much weight on the pressure cap.

(f) Remove the locking screw.

(g) Remove the safety pin. If the safety pin tends to bind, the device is unsafe and should not be used.

(h) *Special Safety Precaution.* This device may fire if the release pin is rotated after the locking screw is loosened or removed and the safety pin is removed. Do not adjust the position of the release pin unless the safety pin and locking screw are securely in place.

(2) **To PICK UP OR RECOVER.**

(a) Replace safety pin and screw the locking screw in place.

(b) Cut the trip wire or remove the pressure tripping device from the pressure cap.

(c) Take up the mine.

(d) Remove fuze, screw on the hexagonal cap, and return the mine and components to original packing.

**d. Precautions.**

(1) No attempt will be made to disassemble the mine (except to

## ANTIPERSONNEL MINES

remove the firing pin assembly when the mine is picked up). Mines with loose caps or primers will not be used until inspection by ordnance personnel shows that the igniter and propelling charge have not been damaged by moisture, and the mine cap and primer assembly have been resealed.

(2) When mines are being planted, place the hexagonal cap from the primer and the locking screw and safety cotter pin near the body of the mine, in a position where they may be readily found if it is necessary to pick up or recover the mines.

(3) While this mine is water resistant, it should not be expected to function after prolonged submergence in water.

### e. Marking and Packing.

(1) The mine and the fuze are painted lusterless olive-drab, except for the flange of the mine base, which is painted yellow. Stenciled on the flange is the type and model of the mine, the lot number, manufacturer's symbol, and date of loading.

(2) The mine is packed one per corrugated paper carton. The carton also contains the firing pin assembly and 1 spool of four 26-foot lengths of wire. Ten such containers are packed in a wooden box. The boxes are marked "OLIVE DRAB" or "SAND COLOR" to indicate the color of the wire packed therein (par. 8).

## 18. MINE, ANTIPERSONNEL, M3.

*see C*  
*see C*  
**a. General.** The MINE, antipersonnel, M3, is a fragmentation type of land mine intended primarily for use against personnel. The complete round consists of the mine, a hollow cast-iron block containing TNT, and FUZE, mine, antipersonnel, M3. It has an effective radius against personnel of 10 yards when fired at the surface of the ground. The effective radius is slightly increased when the mine is used several feet above ground level, and is decreased when the mine is buried in the ground. Fragments of the mine may be thrown more than 100 yards and suitable protection should be provided for friendly personnel within this radius.

### b. Description.

(1) The MINE, antipersonnel, M3, is shown with principal dimensions in figure 13. The cast-iron casing is filled with a 0.90-pound charge of flaked TNT. In two opposite sides and one end, there are holes below which are cap wells. Any one of these holes may be used. As shipped, the holes are closed with plastic plugs. In the end opposite the well is a filling hole which is closed with a metal disk.

(2) FUZE, mine, antipersonnel, M3 (fig. 14), consists of a special blasting cap (U. S. Army blasting cap, type A) crimped to the Combination Firing Device M1 (par. 24) for use with this mine. The firing device contains a spring-loaded firing pin and a primer.

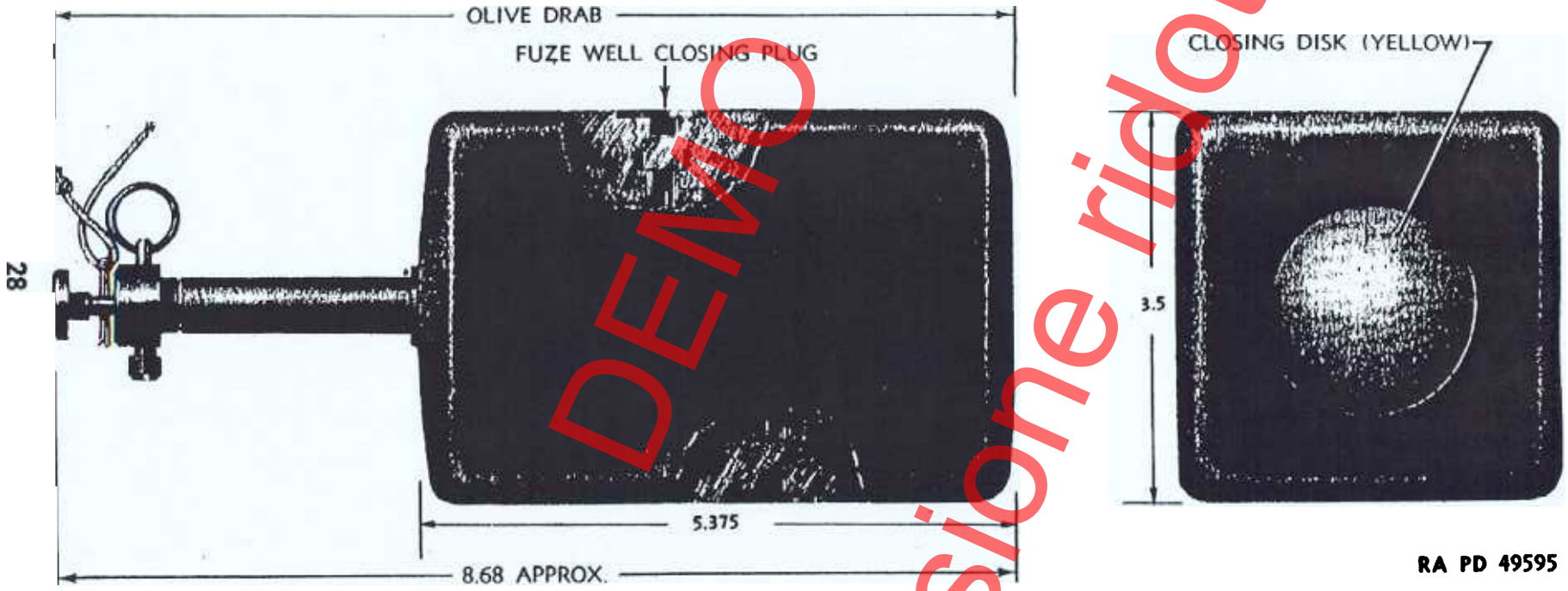
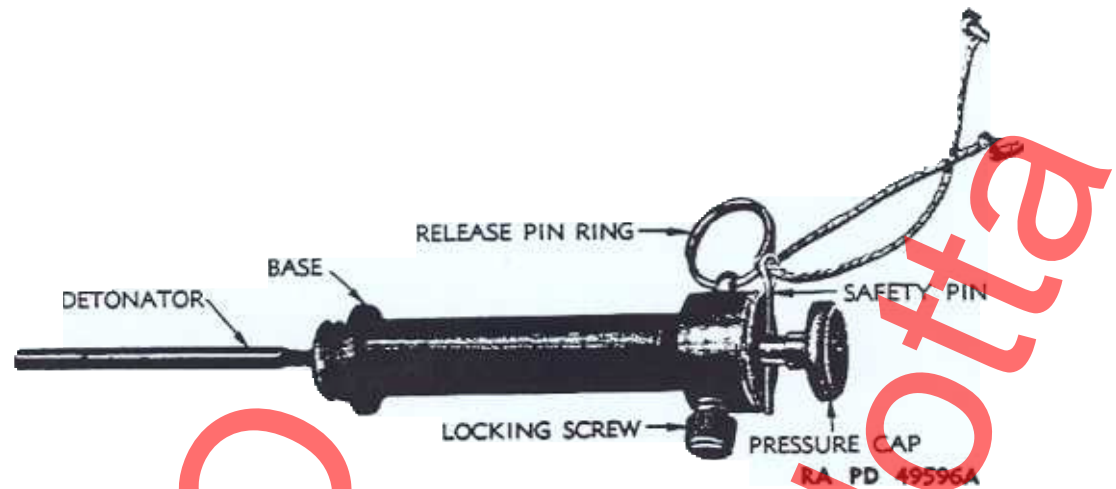

Figure 13 — MINE, Antipersonnel, M3, Complete

dimensione ridotta

## ANTIPERSONNEL MINES



**Figure 14 — FUZE, Mine, Antipersonnel, M3**

It may be fired by means of a cord or wire connected to the release pin ring, or by pressure applied to the pressure cap. A pressure of 20 to 40 pounds on the pressure cap, or a tension of 3 to 6 pounds on the release pin, will release the firing pin and detonate the primer. Wire is furnished for connecting to the pull ring for making tripping devices. A safety pin located in a hole in the firing pin, and a locking screw bearing on a groove in the firing pin, protect the firing device from accidental functioning during shipping and handling. The firing device is issued unassembled to the mine.

**c. Operation.** To assemble the mine, it is only necessary to remove the closing plug from the desired fuze hole and to screw in the firing device firmly. Be sure that the well is clear of foreign material and that the detonator enters freely.

(1) **TO PLANT OR PREPARE FOR ACTION** (par. 24 c).

(a) Remove the closing plug. Use the wrench packed with the mines.

(b) Assemble the fuze to the mine.

(c) Attach a trip wire to the release pin ring, or install a pressure trip on the pressure cap.

(d) Check to see that the trip wire is not too tight, or that there is not too much weight on the pressure cap.

(e) Remove the locking screw and safety pin. If the safety pin tends to bind, the fuze is unsafe and should not be used.

(f) **Special Safety Precaution.** This device may fire if the release pin is rotated after the locking screw is loosened or removed, and the safety pin is removed. Do not adjust the position of the release pin unless the safety pin and locking screw are securely in place.

## LAND MINES

### (2) TO PICK UP OR RECOVER.

- (a) Replace the safety pin and screw the locking screw in place.
- (b) Cut the trip wire or remove the pressure tripping device from the pressure trip.
- (c) Take up the mine.
- (d) Remove the fuze from the mine and replace the closing plug.
- (e) Repack the components in their original packing. The fiber case in which the fuze is packed should be resealed.

### d. Precautions.

(1) No attempt will be made to disassemble the mine or components, except to remove or replace the fuze hole closing plug and assemble or remove the fuze.

(2) Do not remove the locking screw or safety pin from the fuze until the mine is placed and the installation is checked to see that there is not too much tension on the pull ring, or too much pressure on the pressure cap.

(3) Protect the fuze from shock, heat, and friction.

(4) When the mines are being planted, place the fuze hole plug, locking screw, and the safety pin in a position where they may be readily found if necessary to pick up and recover the mines.

(5) Exposure to moisture will not affect the operation of the mine. However, the mine is not waterproof, and should not be planted in positions where it will be immersed in water for more than a few days.

### e. Marking and Packing.

(1) **MARKING.** The mine body and the fuze are painted olive-drab with markings in black. On one side are marked the type and model of the mine, metal parts manufacturer's lot number, and date of manufacture. The opposite side is marked with the type and model, loader's lot number, and date of loading. The closing disk is painted yellow.

(2) **PACKING.** Six mines are packed in a wooden packing case, which also contains six fuzes. The fuzes are packed in sealed cylindrical fiber containers which, in turn, are packed in compartments in one end of the packing box. Packed in the box is a small wrench which fits the square holes in the plastic plugs in the mine and is used for unscrewing them prior to assembling the fuzes. Six spools of wire for making tripping devices are also packed in the box. Each spool has four 26-foot lengths of wire. The boxes are marked "OLIVE DRAB" or "SAND COLOR" to indicate the color of the wire packed therein (par. 8).

**ANTIPERSONNEL MINES****19. TORPEDO, BANGALORE, M1.****a. Description.**

(1) The bangalore torpedo (fig. 15) is a tube or pipe filled with high explosive, primarily used for blasting an opening through wire entanglements or for clearing mine fields. The TORPEDO, bangalore, M1, consists of a steel tube 5 feet in length and  $2\frac{1}{8}$  inches in diameter which is grooved and capped at each end. The tube is filled with amatol, with about 4 inches of TNT at each end. The weight of explosive charge is about 9 pounds. Each end of the tube is capped and contains a recess or well to accommodate a detonator or blasting cap attached to any of the standard firing devices described in section V. A nose sleeve which fits on the end of the torpedo, and connecting sleeves for assembling the torpedoes in multiple lengths, are provided. The torpedoes and accessories are painted lusterless olive-drab.

(2) In addition to clearing wire entanglements and mine fields, this torpedo may also be used as an antitank mine or antipersonnel mine. Because of its high percentage of explosive charge, it may also be used for demolition purposes.

**b. Components and Accessories.** The following parts are used for detonating the torpedoes or placing them in multiple assembly.

**(1) DETONATOR.**

(a) Electric or nonelectric blasting cap may be used to detonate the torpedo. If commercial blasting caps are used, a combination (tetryl) detonator, equivalent to a No. 8, or stronger, blasting cap should be used.

(b) Primacord may be used by inserting primacord in the well and wedging it in place.

(2) **NOSE SLEEVE.** This is a rounded point which fits over the end of a torpedo (fig. 15). It contains a single clip which holds it in place. The nose sleeve is provided for ease in pushing the torpedo through obstacles such as heavy brush or barbed wire. It is not necessary for the proper functioning of the torpedo.

(3) **CONNECTING SLEEVE.** The connecting sleeve (fig. 15) is a short tube into which the ends of two torpedo tubes will fit and be held by three spring clips. It is used when assembling the torpedoes in multiple lengths.

**c. Assembly.** The sleeves and torpedo are alined and forced together until the spring clips on the sleeve snap into the groove on the end of the torpedo.

(1) **ASSEMBLY IN MULTIPLE LENGTHS.** To assemble in multiple lengths, fit a nose sleeve over the leading end of the torpedo. Then fit a connecting sleeve on the other end and fit another torpedo into

LAND MINES

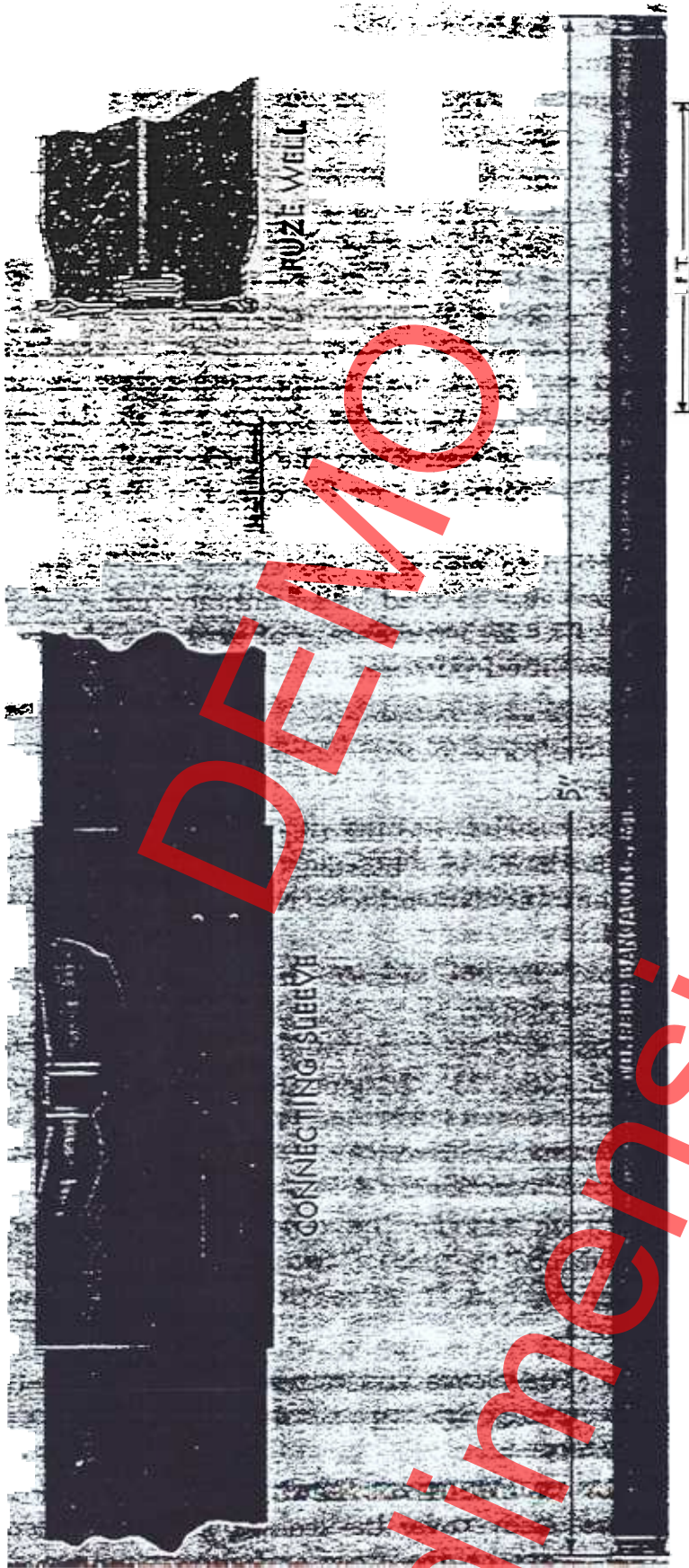

RA PD 69106

Figure 15 — TORPEDO, Bangalore, M1

MEMO  
dimensione ridotta



## ANTIPERSONNEL MINES

the sleeve. Add additional sleeves and torpedoes until the desired length is obtained. One detonator in the cap well at the end will detonate the entire line of torpedoes.

d. **Packing.** TORPEDO, bangalore, M1, is packed 10 in a box, which also contains 10 connecting sleeves, and 1 nose sleeve (par. 8).

### 20. DEMOLITION MATERIALS.

a. **Explosives.** Half- and quarter-pound blocks of compressed TNT and nitrostarch, respectively, are supplied for demolitions and like purposes. These may be used either by themselves with any of the firing mechanisms (sec. V) equipped with a detonator, or may be used to augment any of the mines described herein.

NOTE: Nitrostarch is more sensitive than TNT, consequently nitrostarch blocks will not be crushed or broken.

b. **Primacord.** Primacord consists of a flexible tube filled with high explosive. It is ordinarily used to transmit a detonation from a blasting cap to a charge of high explosive or from one charge of high explosive to another without requiring the use of a second cap. In addition to its function of transmitting a detonation, primacord contains enough high explosive so that it may be used as the main charge of a booby trap by making a flat coil about 3 inches in diameter of 12 to 20 feet of primacord and taping nails, empty cartridge cases, or other metal fragments around it.

### 21. BLOCKS, DEMOLITION, CHAIN, M1.

a. **General.** BLOCKS, demolition, chain, M1, assembly (figs. 16 and 17), consists of eight 2- by 2- by 11-inch blocks of tetrytol strung on a 16-foot length of primacord (par. 20 b) and packed in a haversack. The assembly is provided primarily for demolition purposes and is designed for ease in use and handling. The entire chain, or any part of the chain, may be used laid out in a line, wrapped around an object, or as packed in the haversack.

b. **Description.** Each block is rectangular in shape and is enclosed in a crinkle kraft paper bag. Printed on the bag in at least one place, is the designation: "DEMOLITION BLOCKS, M1 (TETRYTOL). MUST BE DETONATED BY CORPS OF ENGINEERS, U. S. ARMY, BLASTING CAP. ONE BLOCK - SIX ½-LB. TNT BLOCKS." The blocks are cast in place on the primacord with 8 inches between blocks and 2 feet of primacord free at each end. They consist of tetrytol, which is 75 percent tetryl and 25 percent TNT, with a cylindrical pellet of tetryl cast in each end of each block. The dimensions of the haversack are approximately 12½ by 9 by 4½ inches, and its weight, packed, is 22.5 pounds.

c. **Characteristics.** Tetrytol is more powerful and more brisant than TNT: hence these blocks are more effective in cutting steel

# LAND MINES

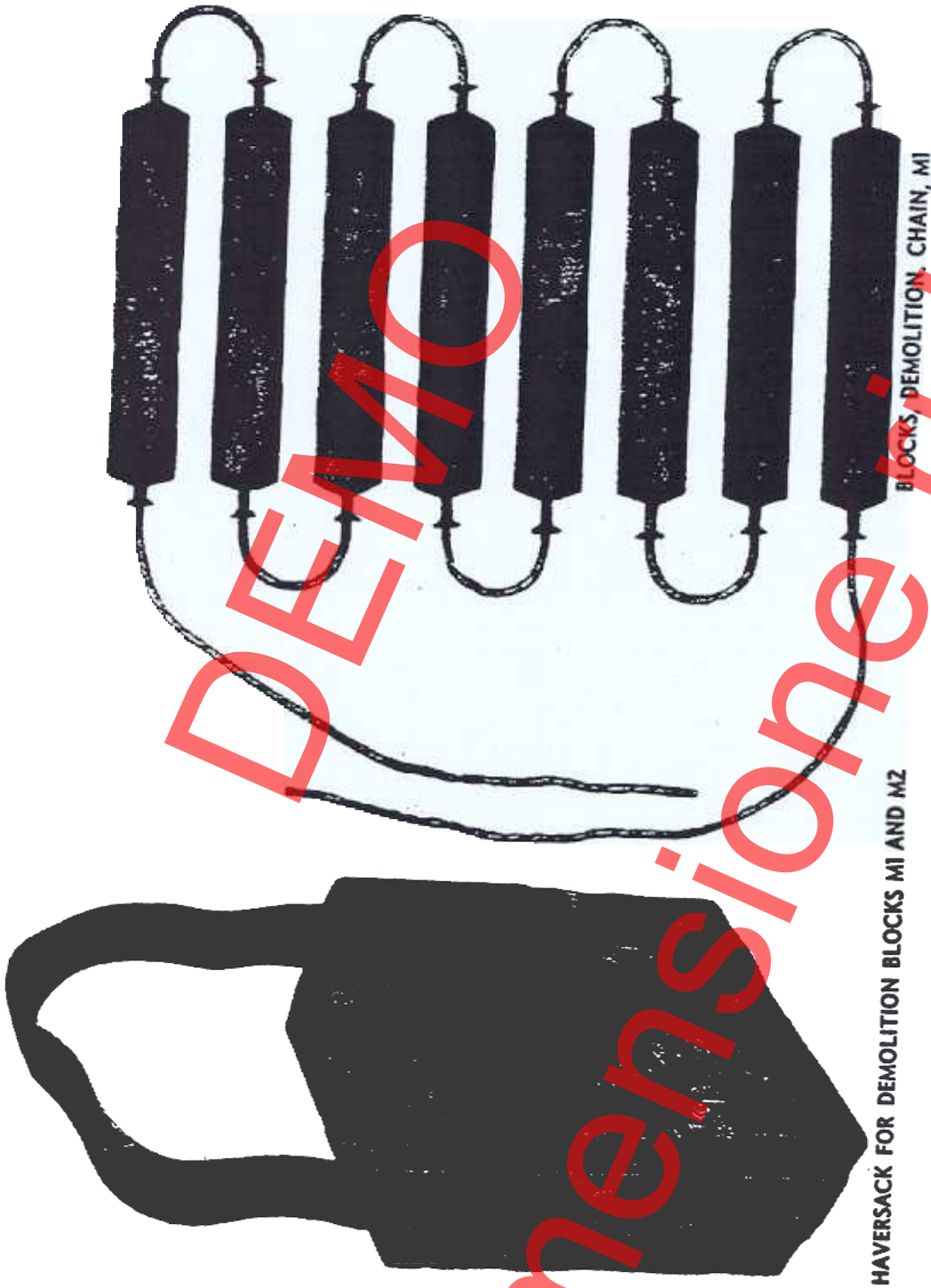

HAVERSACK FOR DEMOLITION BLOCKS MI AND MZ

BLOCKS, DEMOLITION, CHAIN, MI

Figure 16 BLOCKS, Demolition, Chain, M RA PD 69107

ANTIPERSONNEL MINES

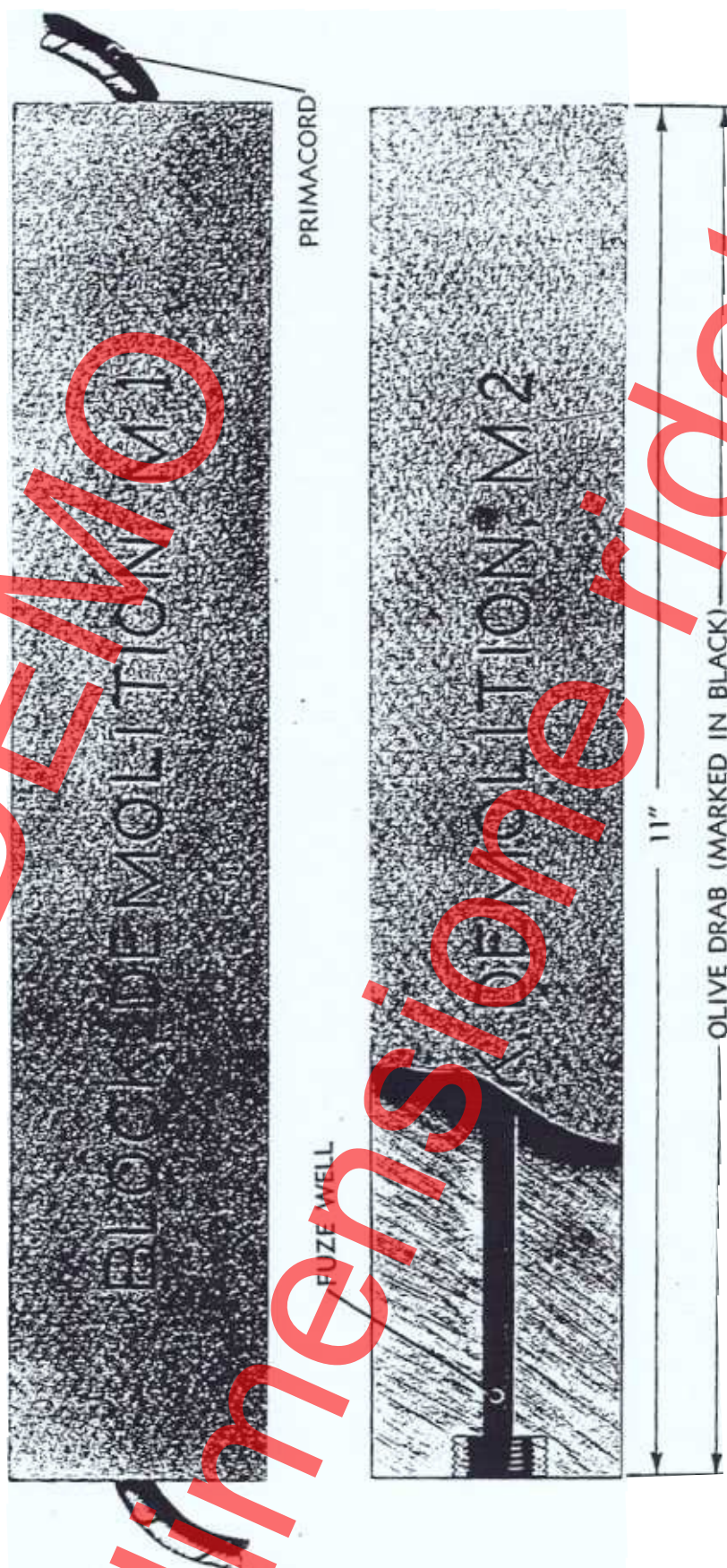

RA PD 69108

Figure 17 Demolition Blocks

## LAND MINES

and in demolition work. If necessary, each block may be broken within its bag, but care should be exercised not to break the primacord. The blocks and primacord are comparatively insensitive to shock, but the assembly, that is, with tetryl pellet, is slightly more sensitive than TNT.

d. **Use.** It is necessary to detonate the primacord by means of a blasting cap or detonator in order to fire the entire chain. Sympathetic detonation of unconnected blocks can be obtained when they are separated by as much as 10 inches of air.

### 22. DEMOLITION BLOCKS.

a. **BLOCK, Demolition, M2.** BLOCK, demolition, M2 (fig. 17), is a rectangular block of tetrytol 2 by 2 by 11 inches, with a detonator well in each end. At the outer end of each well there is an adapter threaded to receive any of the standard firing devices. At the inner end of each well, there is a tetryl pellet cast in the block to act as a booster. Each block is wrapped in olive-drab paper on which is printed "BLOCK, DEMOLITION, M2" and "EQUIVALENT TO SIX ½-POUND TNT BLOCKS". This block, except for the replacement of the primacord by detonator wells, is similar to BLOCKS, demolition, chain, M1. It is packed in the same manner and has the same properties and uses.

b. **BLOCK, Demolition, M3.** BLOCK, demolition, M3, is a rectangular 2¼-pound block of plastic explosive 2 by 2 by 11 inches. It is packed in a cardboard box which is marked:

HIGH EXPLOSIVE  
Composition C-2

"One block is equivalent to six ½-pound TNT blocks."

(1) This plastic explosive can be moulded by hand into any desired shape or position and is very efficient as a result of the good contact thus obtained combined with its high power. The explosive is plastic at temperatures ranging from 20 F below to 125 F above zero and is resistant to the action of water. BLOCK, demolition, M3, is packed in a cardboard box, eight such boxes per haversack, two haversacks per box.

c. **BLOCK, Demolition, M4.** BLOCK, demolition, M4, is a ½-pound block of high-explosive composition C 2, packed in a cardboard box 6.75 by 1.5 by 1 inch. These are packed without haversack, about 52 pounds per wooden box.

**Section V**

**FUZES AND FIRING MECHANISMS**

	<b>Paragraph</b>
General .....	23
Combination firing device M1 .....	24
Pull firing device M1 .....	25
Pressure firing device M1 .....	26
Release firing device M1 .....	27
Blasting caps .....	28

RA PD 68322A

- A — PULL FIRING DEVICE, M1
- B — PRESSURE FIRING DEVICE, M1
- C — COMBINATION FIRING DEVICE, M1

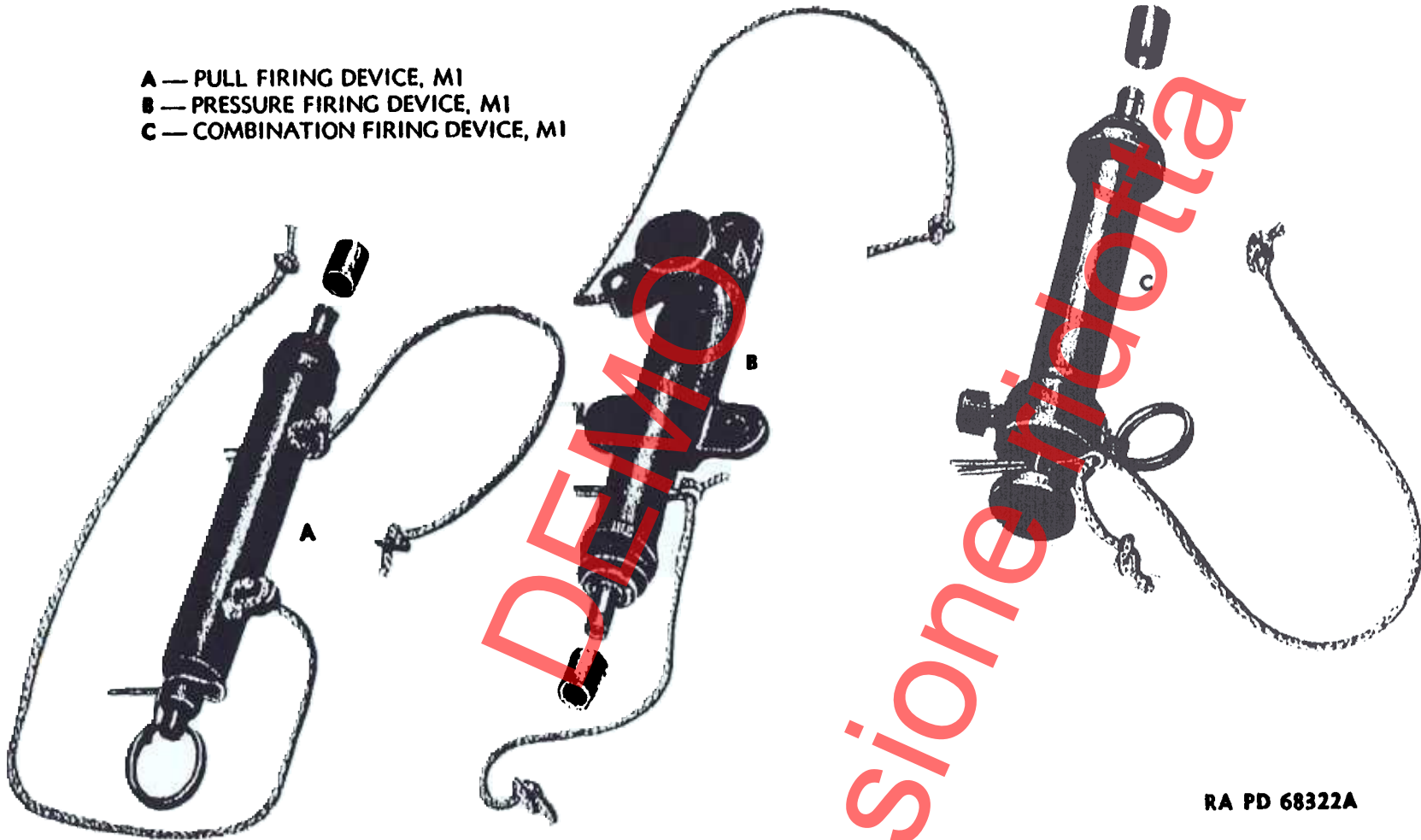

Figure 18 Firing Devices

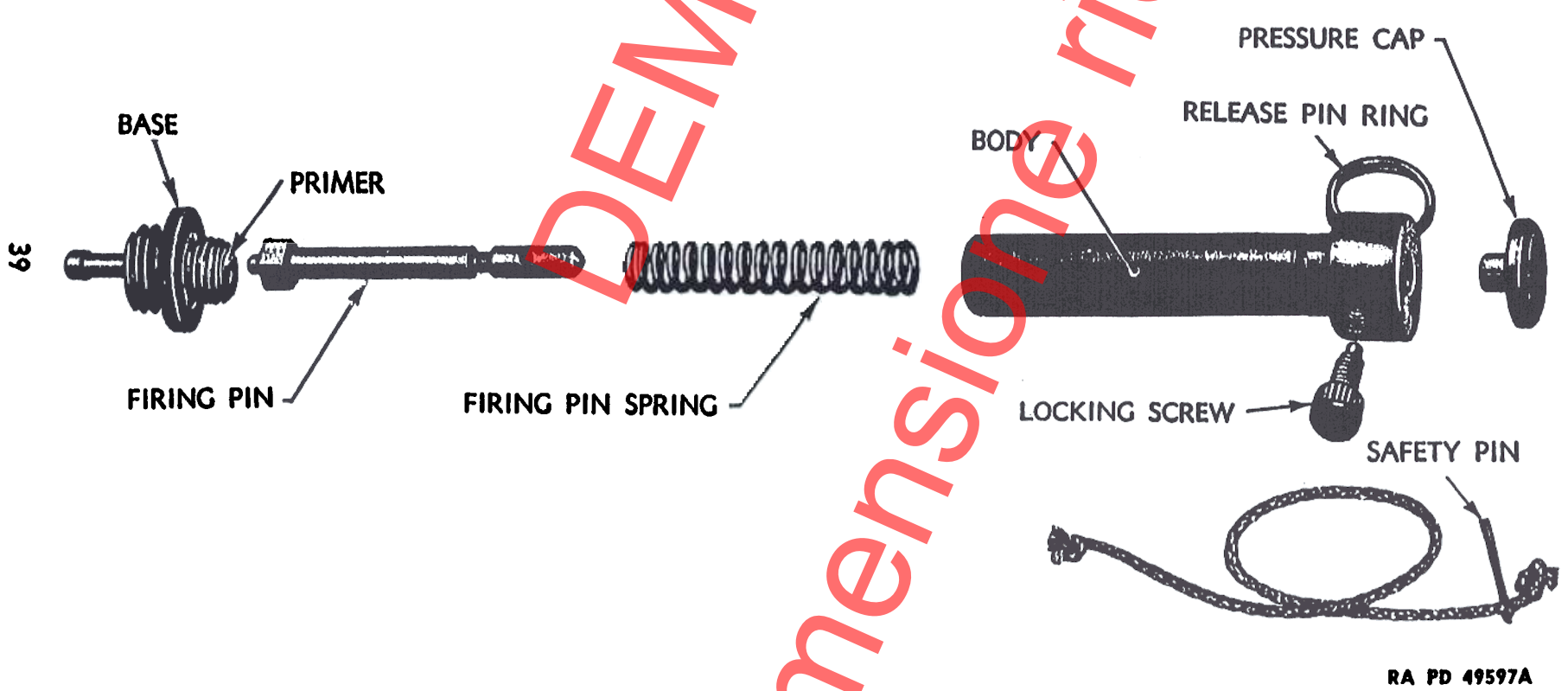

Figure 19 — Combination Firing Device M1

## FUZES AND FIRING MECHANISMS

### (4) FOR USE AS A PRESSURE FIRING MECHANISM (par. 26).

(a) Prepare the pressure trip installation, making sure that there is a firm attachment for the firing mechanism and that the pressure trip does not bear too heavily on the pressure cap.

(b) Attach blasting cap and prime charge as above.

(c) Install mechanism and pressure trip. Make sure that the installation is not detectable.

(5) The final operation is to remove the locking screw while the safety pin is in place. If there is too much pressure or tension on the firing device the safety pin will tend to bind and the installation should be checked. If the safety pin does not bind, gently remove it and leave both safety pin and locking screw concealed near the mine in case it should be necessary to disarm and take up the mine.

### 25. PULL FIRING DEVICE M1.

a. **Description.** The Pull Firing Device M1 (procured from Corps of Engineers) is a nonelectrical mechanism, designed primarily for use with a trip wire, for firing mines or other explosive charges. A direct pull of from 3 to 5 pounds applied to the trip wire releases the firing pin, which is driven by the compression spring into a percussion cap fitted in the base. This percussion cap fires a nonelectric blasting cap, attached to the base, which in turn detonates the explosive charge. The device (figs. 18 and 20) measures approximately  $4\frac{3}{4}$  inches long by  $\frac{5}{8}$  inch diameter. It consists of a head, a housing tube, and a base. The head contains a release pin, a safety pin, and a loading spring. The housing tube contains the firing pin, the firing pin compression spring, and a second safety pin which passes through the body between the firing pin and the percussion cap. The base contains a recess into which a percussion cap is placed, and a projection to which a nonelectric blasting cap is crimped when the firing device is loaded. The firing mechanism consists of a firing pin, a compression spring, a release pin assembly, and a loading spring. The split head of the firing pin is forced against pressure of the compression spring through a small opening or well, in the housing. The release pin enters into and expands the split head of the firing pin spindle against the sides of the well, thus preventing its return, although the striker is under pressure from the compression spring. The release pin is held in position by the loading spring. Holes in the main head and in the release pin allow insertion of safety pins, thus preventing accidental movement of the release pin to fire the cap. A soldered joint is made between the main head and the housing tube, so that this part of the device cannot be taken apart. A short piece of flexible wire terminating in a loop is attached to the housing tube at this joint. This is to be used as an anchorage for the firing



## LAND MINES

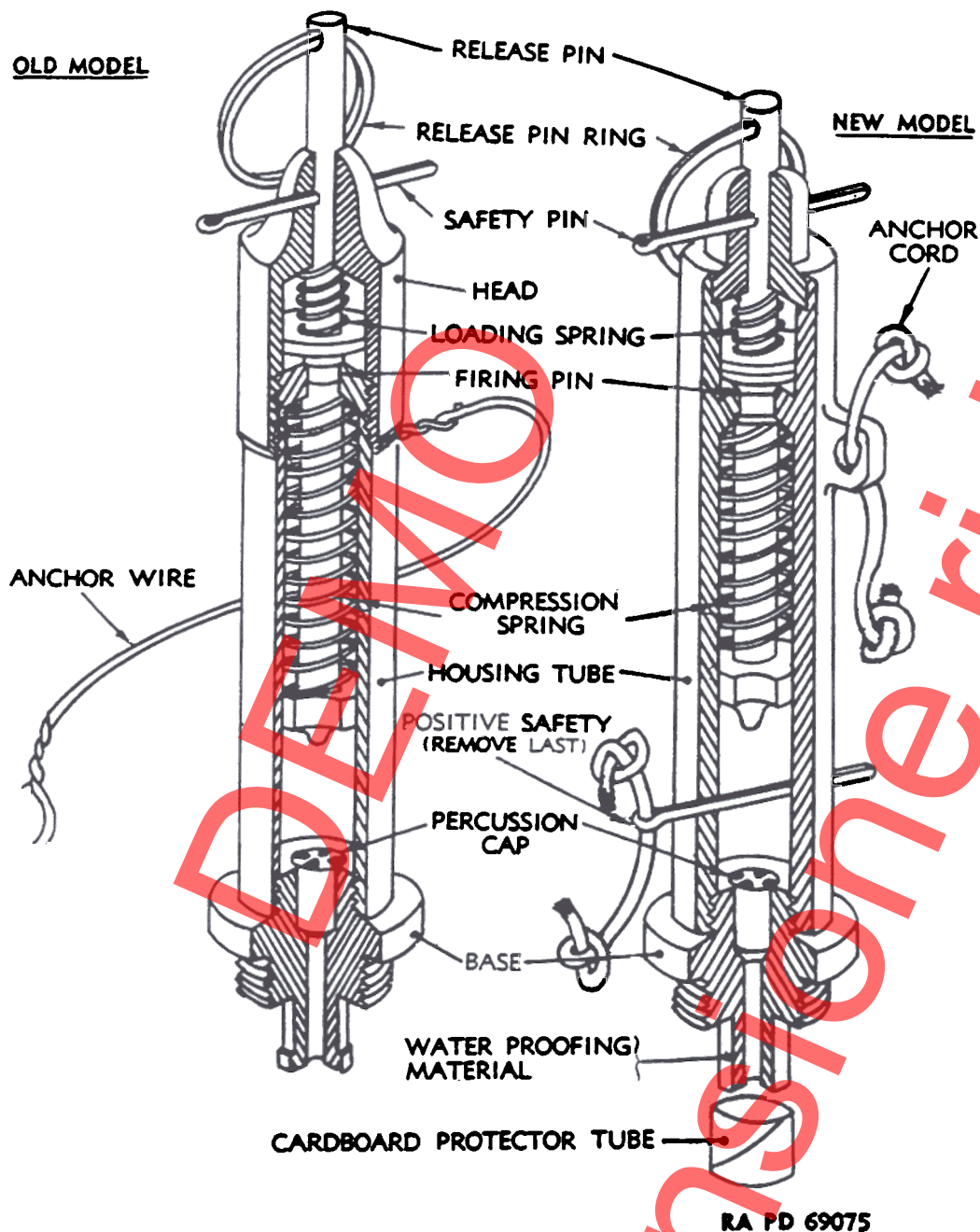

**Figure 20 — Pull Firing Device M1**

device. The ring on the release pin facilitates fastening the trip wire to the device. The safety pin through the body positively restrains the firing pin from striking the percussion cap.

b. **Functioning.** When the safety pins are removed, a pull of from 3 to 5 pounds applied through a distance of about  $\frac{1}{32}$  inch is sufficient to overcome the resistance of the loading spring and cause the tapered end of the release pin to be withdrawn from within the

## FUZES AND FIRING MECHANISMS

split head of the firing pin. The split head of the spindle, being no longer forced against the well, slips through under the influence of the compression spring. This forward movement of the firing pin continues until it strikes the head of the percussion cap contained in the base of the device. The percussion cap is thus fired, and detonates a nonelectric cap crimped to the base.

c. **Installation.** This device is installed in a manner similar to the combination firing device (par. 24) except that the safety pin through the body is removed last, after all other preparations have been made and tested.

d. **Packing.** Pull firing devices are packed in boxes, each box containing five devices complete with percussion caps and two 80-foot spools of light trip wire. The boxes measure  $4\frac{3}{4}$  by  $4\frac{7}{8}$  by  $1\frac{5}{8}$  inches. Each full box weighs 1 pound 3 ounces.

### 26. PRESSURE FIRING DEVICE M1.

a. **Description.** The Pressure Firing Device M1 (procured from Corps of Engineers) is a nonelectrical device designed to cause the detonation of antipersonnel mines or other explosive charges when the device is subjected to a pressure of 30 pounds or more. The device (figs. 18 and 21) is mounted on a rectangular metal base plate, measuring  $2\frac{1}{2}$  by  $1\frac{1}{2}$  inches, and is composed of a barrel, head, and base. The barrel contains the firing mechanism and a safety pin. The head, permanently joined to the barrel, contains the trigger assembly. The base, which screws into the barrel, contains a recess into which a percussion cap fits and a projection over which a nonelectric blasting cap is crimped. (The base and percussion cap are identical with those used on the Pull Firing Device M1.) The firing mechanism consists of a striker assembly, a striker spring, a trigger assembly, and a trigger spring. The striker assembly consists of a round spindle, with a groove three-eighths of an inch from the end opposite the striker, the striker head, and a firing pin mounted on the striker head. The trigger unit consists of a large, flat head mounted on a trigger pin extending through the side and down into the barrel. The trigger pin has a pear-shaped hole in it. The small section of the spindle fits in the small end of a pear-shaped hole so that the striker spring is unable to cause movement of the striker and firing pin. A safety clip extends around the trigger pin, between the barrel and the trigger head. No appreciable movement of the trigger pin against the action of the trigger spring is possible until the safety clip is removed. The firing pin is restrained from striking the percussion cap until the safety pin through the body is removed.

b. **Functioning.** When the safety clip is removed, a force of from 25 to 35 pounds applied to the trigger head through a distance of three-sixteenths of an inch is sufficient to overcome the resistance of

## LAND MINES

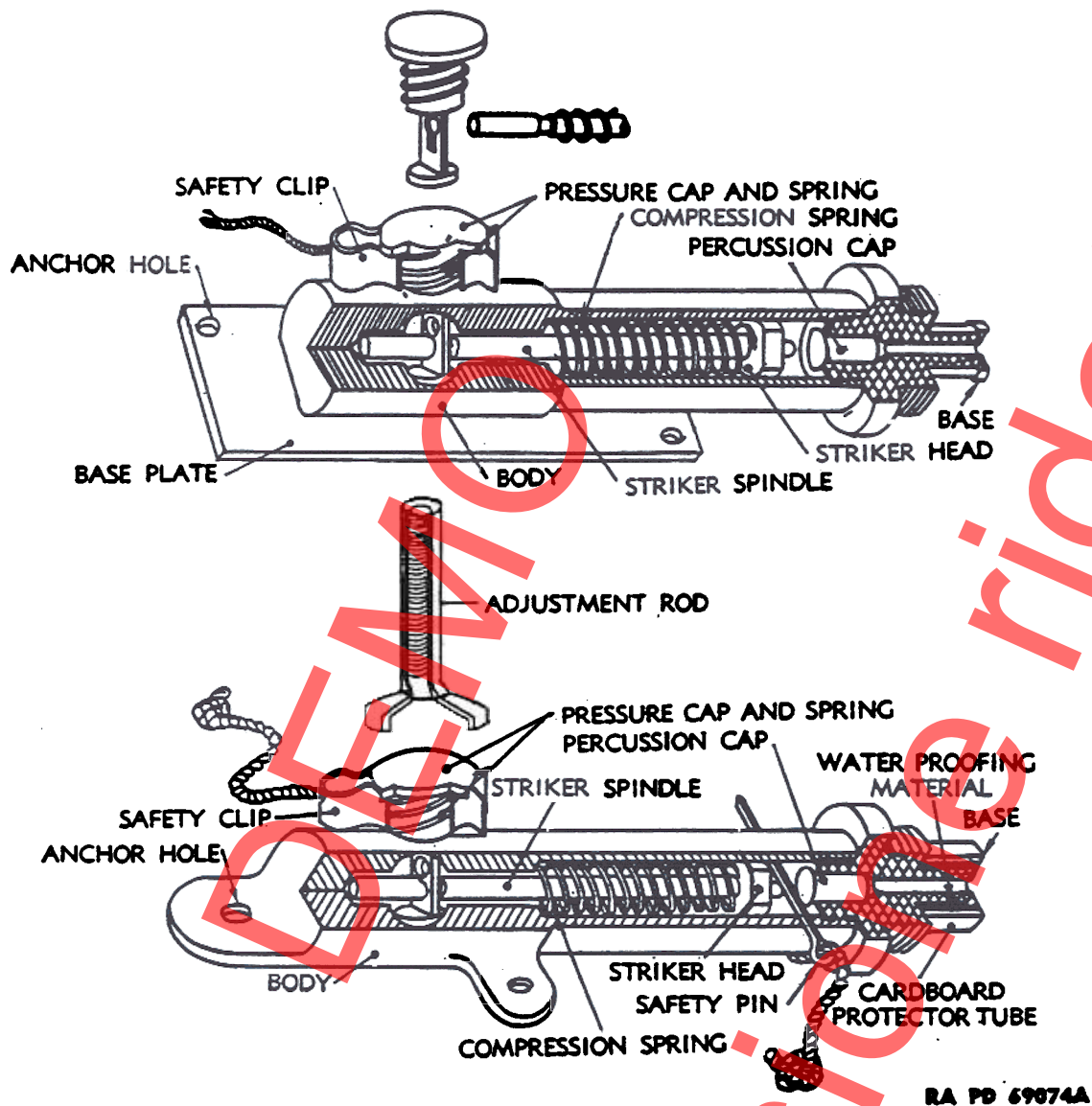

**Figure 21 Pressure Firing Device M1**

the trigger spring and cause the trigger pin to move into the barrel, permitting the striker and firing pin to be driven forward and strike the percussion cap. The percussion cap detonates a nonelectric blasting cap crimped to the projection on the base.

**c. Installation.** To install the Pressure Firing Device M1, the procedure is as follows:

(1) Prepare and place the mine charge as for the combination firing device (par. 24).

(2) Keeping the safety clip in position on the firing device, remove the base containing the percussion cap.

(3) Place the firing device in position at the location where it is to be used. Be sure that it has solid footing. Place the pressure

LAND MINES

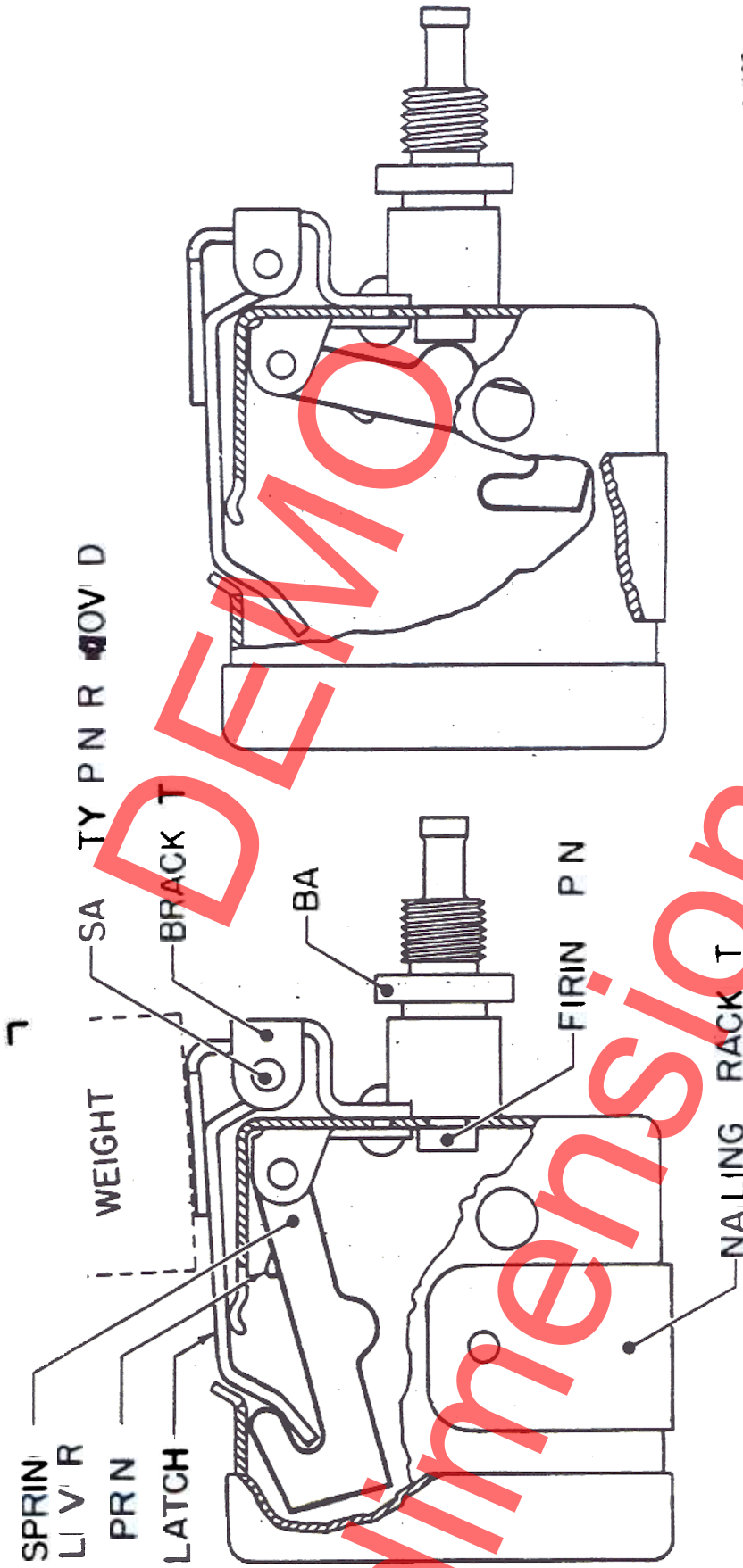

PD 35638

Figur 2 leuse i-i) Devi Mi

release pin ring of 6 to 10 pounds, moving it  $\frac{1}{2}$  inch, or a load on three prongs of 10 to 20 pounds, or on one prong of 10 to 30 pounds, moving the trigger pin  $\frac{1}{2}$  inch, will release the firing pin and operate the fuze.

(2) FUZE, mine, combination, M7 is 7.13 inches in length. The threaded portion of the base is  $\frac{1}{4}$  inch long. The detonator consists of CAP, blasting, U. S. Army special, type A. A pull on the release pin ring of 6 to 10 pounds, moving it  $\frac{1}{2}$  inch, or a load on the three prongs of 10 to 20 pounds, or on one prong of 10 to 30 pounds, moving the trigger pin  $\frac{1}{2}$  inch, will release the firing pin and operate the fuze.

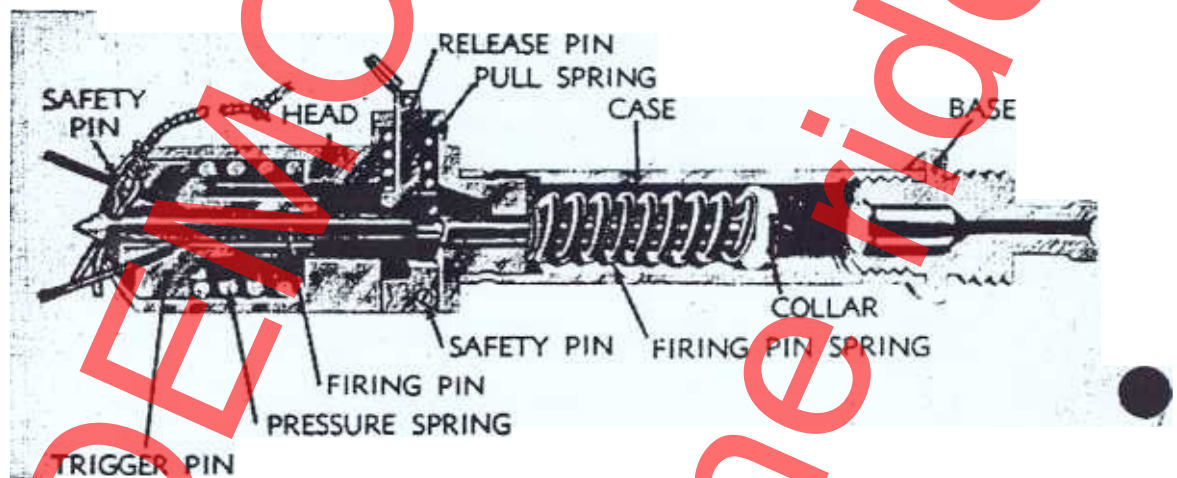

RA PD 15122B

Figure 19.1. FUZE, mine, combination, M6 and M7.

[A. G. 300.7 (4 Apr 44).]

BY ORDER OF THE SECRETARY OF WAR:

G. C. MARSHALL,  
Chief of Staff.

OFFICIAL:

J. A. ULIO,  
Major General,  
The Adjutant General.

DISTRIBUTION:

As prescribed in paragraph 9a, FM 21-6, R 9(4); IR 5(5);

Ibn 5(5); Bn 2, 4, 6, 7, 9, 17, 18, 44(2); IC 5(10); C 9(8);

IR 5: T/O 5-171, T/O & E 5-192.

IBn 5: T/O 5-225, 5-455; T/O & E 5-215, 5-415.

IC 5: T/O & E 5-17, 5-387, 5-417, T/O 5-216, 5-226.

For explanation of symbols, see FM 21-6.