

# Atlante del Materiale d'Artiglieria

## Indice delle Tavole.

Cannone da 42	suo congegno di chiusura	Tav.	1
„	„	„	2
„	da 47	„	3
„	„	„	4
„	da 70	„	5
„	da 75 A	„	6
		„	7
Cannone da 75 M. 906 e suo congegno di chiusura	}	„	8
		„	9
		„	10
Cannoni da 87 A e 87 B		„	11
Congegni di chiusura dei cannoni da 87 A e B		„	12
Congegno di chiusura del cannone da 87 M. 98		„	13
Mortaio da 87 e congegno di chiusura		„	14
Cannoni da 120		„	15
„ da 149 A e G		„	16
„ da 120 e 149 per batterie a cannoniera minima		„	17
„ da 120 per torri corazzate e da 149 e 120 a sfera		„	18
Obici da 149 e 210, mortaio da 210		„	19
Congegno di chiusura dei cannoni ed obici di medio calibro ordinari	}	„	20
		„	

Congegno di chiusura del mortaio da 210 . . . . .	Tav. 21
„ „ per cannoni ed obici di medio calibro a percussione . . . . .	„ 22
Cannone da 149 A per installazione a pozzo . . . . .	„ 22 <sup>bis</sup>
Mortaio da 149 e suo congegno di chiusura } . . . . .	„ 23
Funzionamento del ritegno a chiocciola . . . . .	„ 24
„ . . . . .	„ 25
„ . . . . .	„ 26
Cannone da 321 e suo congegno di chiusura } . . . . .	„ 27
„ . . . . .	„ 28
Cannoni da 240 lungo e corto . . . . .	„ 29
Obici da 280 lungo e corto . . . . .	„ 30
Obici da 280 A e B . . . . .	„ 31
Cannone da 400 . . . . .	„ 32
Obice da 280 K . . . . .	„ 33
Cannone da 254 B . . . . .	„ 34
„ da 152 B . . . . .	„ 35
„ da 152 C . . . . .	„ 36
„ da 152 A (R. M.) . . . . .	„ 37
„ da 149 C e 120 A (R. M.) . . . . .	„ 38
„ da 57 H e 37 H . . . . .	„ 39
Affusto da campagna per cannoni da 87 B . . . . .	„ 40
„ „ „ da 87 M. 98 . . . . .	„ 41
„ „ „ „ . . . . .	„ 42
Avantreno e retrotreno per munizioni da 87 } . . . . .	„ 43
„ . . . . .	„ 44
Affusto ed avantreno da 75 A } . . . . .	„ 45
„ . . . . .	„ 46
„ . . . . .	„ 47
„ . . . . .	„ 48
Affusto ed avantreno da 75 M. 306 } (.....)	„ 49
„ . . . . .	„ 50
„ . . . . .	„ 51
„ . . . . .	„ 52
Affusto da montagna per cannone da 70 } . . . . .	„ 53
„ a ruote per cannone da 57 . . . . .	„ 54
„ „ „ da 42 . . . . .	„ 55
„ d'assedio da 149 G } . . . . .	„ 56
„ . . . . .	„ 57
„ „ da 149 A } . . . . .	„ 58
„ . . . . .	„ 59
„ „ da 120 leggero e pesante . . . . .	„ 60
„ . . . . .	„ 61
Rotaie a cingolo per affusti e carrelli } . . . . .	„ 62
„ . . . . .	„ 63

ANTEPRIMA RIDOTTA  
PAGINE MANCANTI  
TALPO.IT

Affusto da difesa da 149 con sott'affusto del N. 8 . . . . .	Tav. 64
" " da 149 " " 9 . . . . .	" 65
" " da 120 " " 10 e 11 . . . . .	" 66
" " da 149 " " 21 con ripari . . . . .	" 67
" " da 149 " " 8 e 21 trasformati a perno centrale . . . . .	" 68
Congegno di abboccamento: Verricelli amovibili . . . . .	" 69
Affusto da difesa per cann. da 240 rialzato con sott'affusto del N. 1 . . . . .	" 70
Affusto da difesa per cann. da 240 basso " " 5 . . . . .	" 71
Affusto da difesa per cannone da 321 con sott'affusto del N. 7 } . . . . .	" 72
	" 73
	" 74
	" 75
Affusto da difesa per obice da 280 corto con sott'affusto del N. 15 . . . . .	" 76
" " " " 20 " " 20 . . . . .	" 77
" " " " 280 lungo " " 20 . . . . .	" 78
Affusto da difesa per obice da 280 K . . . . .	" 79
" " " " da 280 A . . . . .	" 80
" per mortaio da 149 con sott'affusto del N. 13 . . . . .	" 81
" " da 210 " " 19 } . . . . .	" 82
	" 83
" da difesa per cannone da 149 per batteria a cannoniera minima con sott'affusto del N. 14 . . . . .	" 84
Affusto per obice da 280 corto con sott'affusto del N. 18 } (idroneumatico) . . . . .	" 85
	" 86
" per cannoni a sfera da 149 e 120 . . . . .	" 87
" a candeliere per cannone da 57 . . . . .	" 88
" articolato per cannone da 149 C . . . . .	" 89
" a cassone per cannone da 120 A (P. M.) . . . . .	" 89
" a piedestallo per cannone da 57 H . . . . .	" 89
" a scomparsa da 57 in torretta corazzata . . . . .	" 90
Torre da 400 . . . . .	" 91
Affusto corazzato da 120 } . . . . .	" 92
	" 93
Installazione a pozzo da 149 A tipo A (+) . . . . .	" 94
" " da 149 A tipo A } particolari (++) . . . . .	" 95
" " da 149 A tipo A (+++)	" 96
" " da 149 A tipo A. M. . . . . (++++)	" 97
" " da 149 A tipo G . . . . . (+++++)	" 98
" " da 120 G tipo I . . . . . (++++++)	" 99
" " da 149 G tipo I . . . . . (+++++++)	" 100
" " da 149 S tipo Schneider . . . . .	" 101
Impianto costiero per cannone da 254 B . . . . .	" 102
Affusto a cassa per cannone da 152 B . . . . .	" 103
" " " da 152 C . . . . .	" 104

Affusto a piedestallo per cannone da 152 A (R. M.)	Tav. 105
	„ 106
Cannone da 75 M. 911 e suo congegno di chiusura	„ 107
	„ 108
	„ 109
Cannone da 65 e suo congegno di chiusura	„ 110
	„ 111
Cannone da 305 e suo congegno di chiusura	„ 112
	„ 113
Obice da 149 A campale	„ 114
	„ 114 <sup>bis</sup>
Affusto per obice da 149 A campale	„ 115
	„ 115 <sup>bis</sup>
Inneschi di spolette, e spolette a percussione per proietti carichi di polvere	„ 116
Spolette a percussione per proietti a bocchino anteriore carichi di alto esplosivo	„ 117
Spolette a percussione per proietti a bocchino posteriore carichi di alto esplosivo	„ 118
Spolette a tempo e a doppio effetto	„ 119
„ „ „ „ recenti	„ 120
Pall	„ 121
Granate ordinarie e a frattura prestabilita	„ 122
„ torpedini	„ 123
„ perforanti	„ 124
Shrapnel	„ 125
Corone di fissamento e di centramento	„ 126
Bossoli per cartocci	„ 127
Inneschi per bossoli	„ 128
	„ 129
	„ 130
Impianto costiero per cannone da 305	„ 131
	„ 132
	„ 133
Affusto per cannone da 65	„ 134
	„ 135





### CANNONE DA 42 A CARICAMENTO RAPIDO

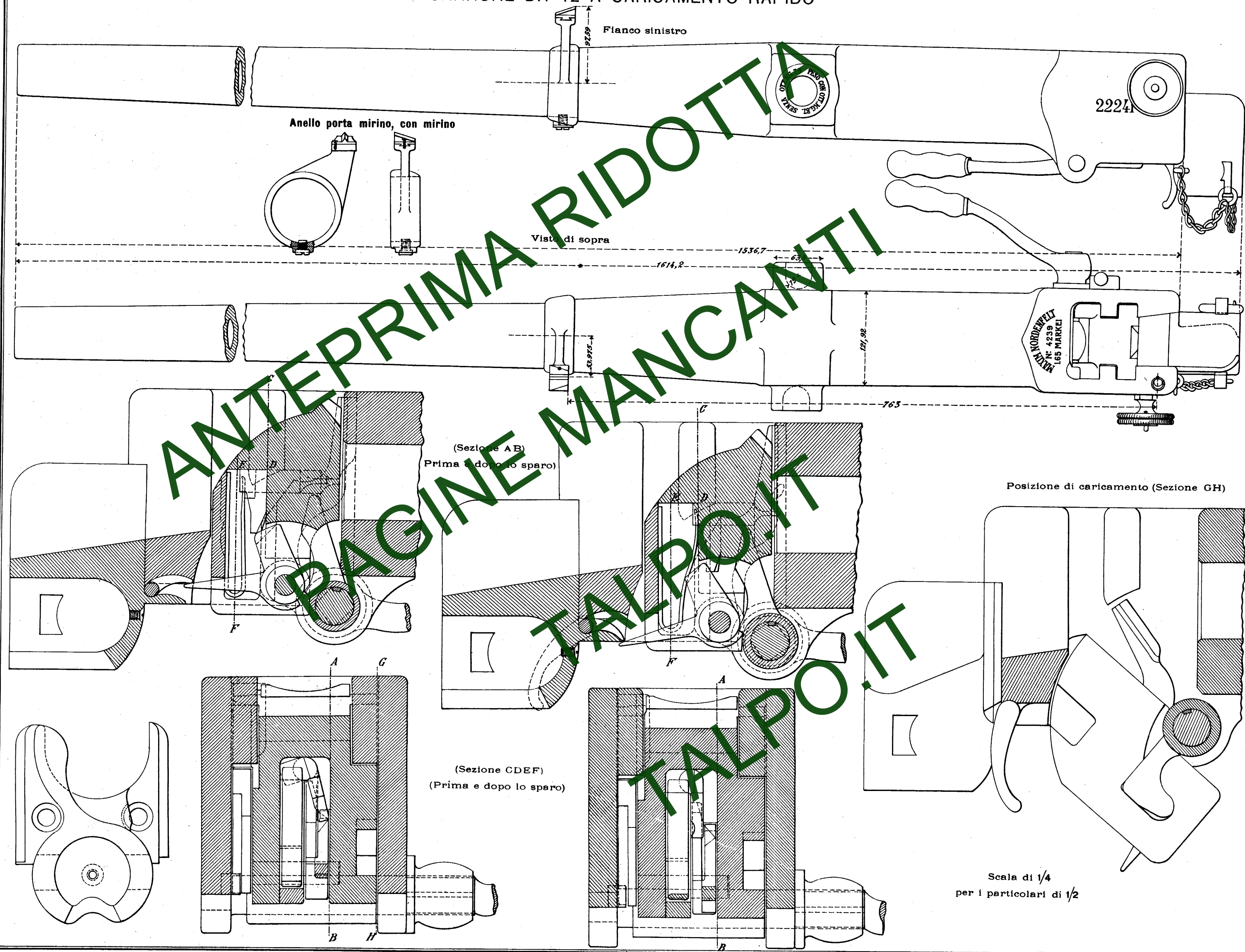

### CANNONE DA 42 A CARICAMENTO RAPIDO

Prisma di culatta (Parte sinistra)

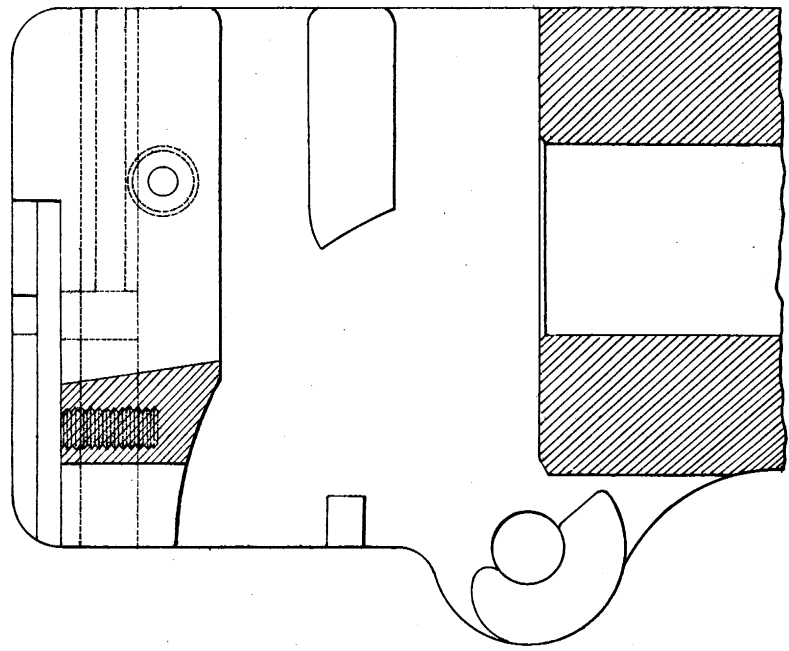

Posizione del congegno ferma albero

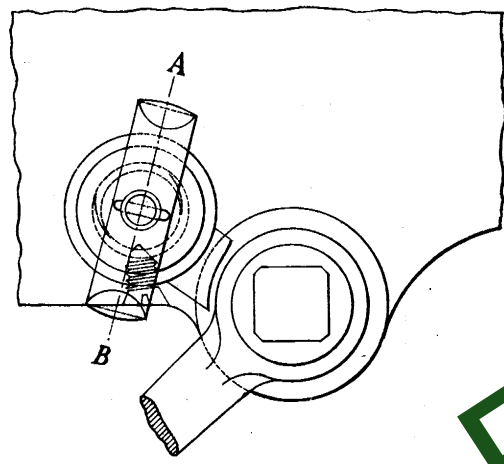

(Sezione A-A)



Blocco otturatore

(Visto davanti)

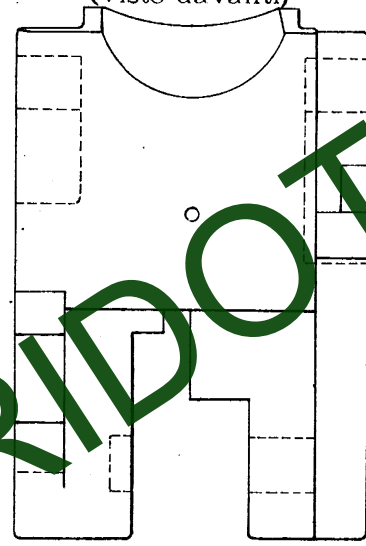

(Visto di dietro)

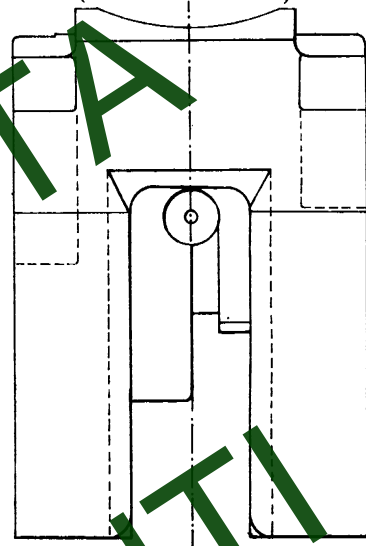

Prisma di culatta (Parte destra)

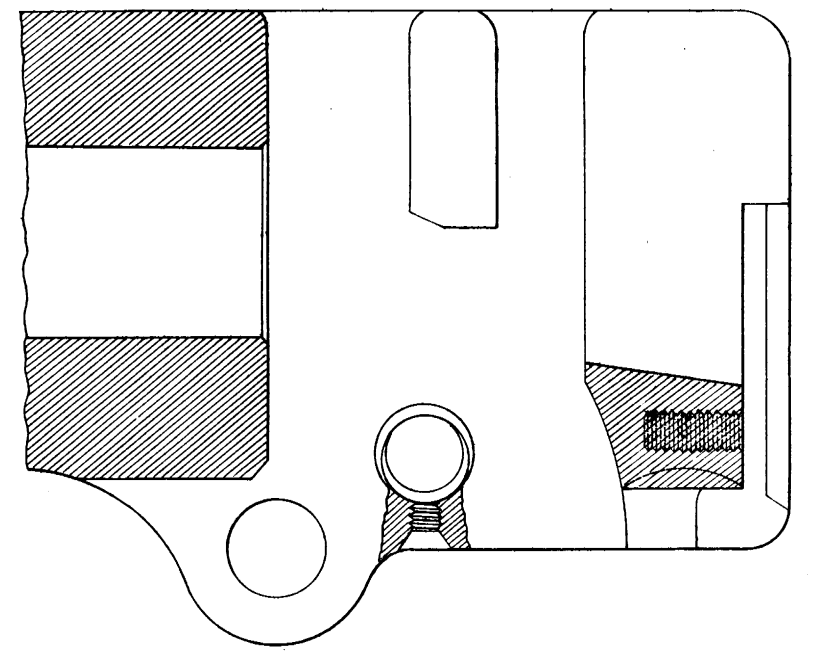

Blocco otturatore

(Fianco sinistro)

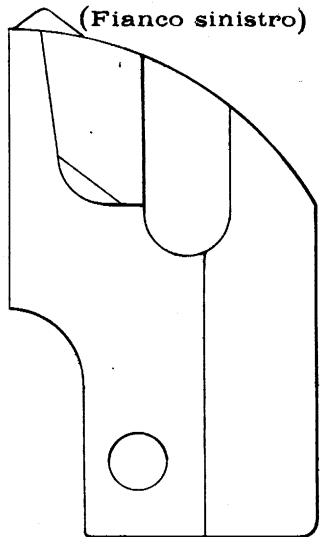

(Fianco destro)



(Sezione CD)

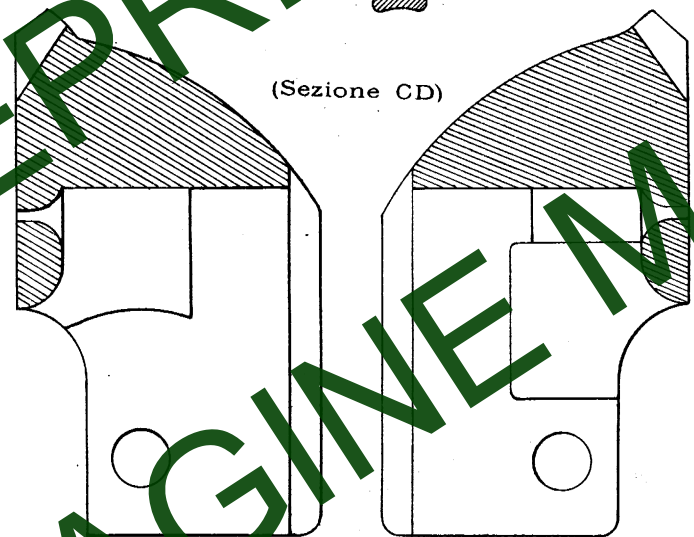

Chiavetta d'arresto dell'anello di ritegno

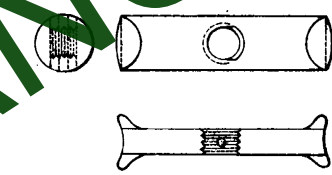

Copiglia della vite d'unione



Guida d'unione dell'anello di ritegno

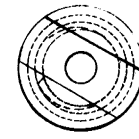
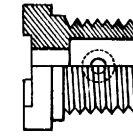

Anello di ritegno dell'albero

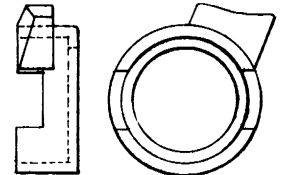

Grilletto

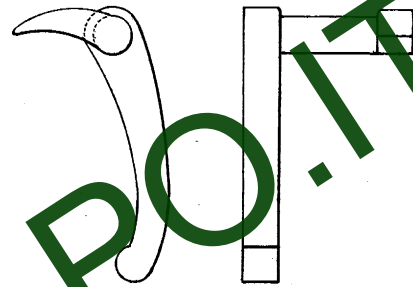

Vite d'unione della chiavetta

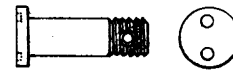

Molla della vite d'unione



Vite di ritegno del congegno

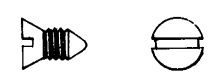

Scatto

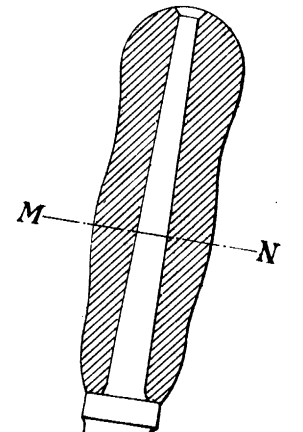
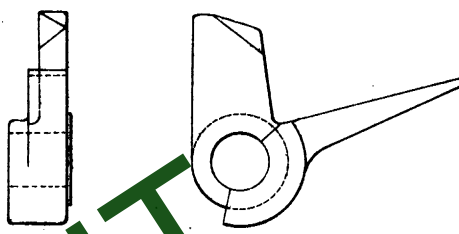

(Visto di sopra)

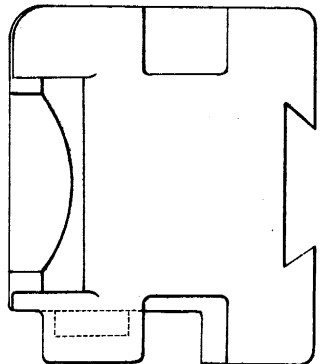

(Visto di sotto)

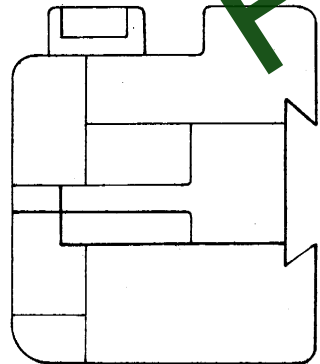

Percussore

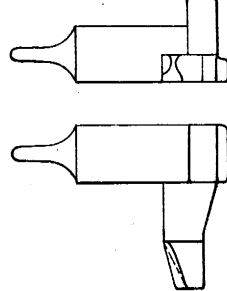

Estrattore

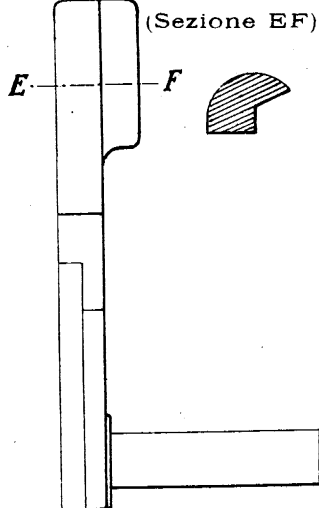

Piastretta del mollone



Mollone

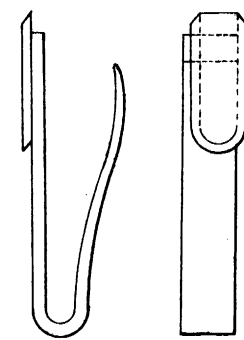

Sezione MN

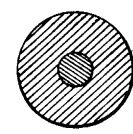

Manicotto dell'albero dell'otturatore

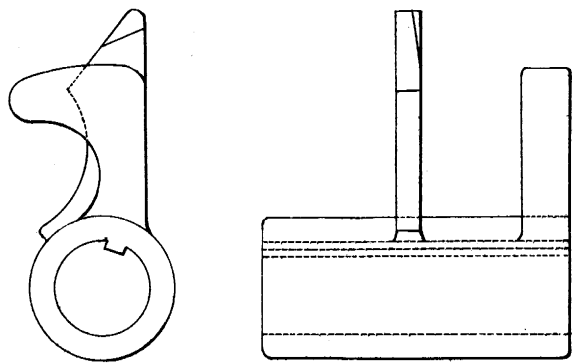

Albero dell'otturatore con leva a manubrio

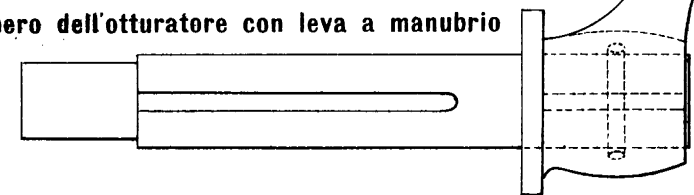

Scala di 12

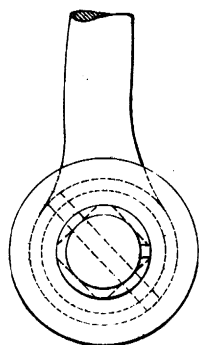

ANTEPRIMA RIDOTTA  
PAGINE MANGANTI  
TALPO.IT



MODIFICAZIONI AGLI OTTURATORI DI MEDIO CALIBRO PER RIDURLI A PERCUSSIONE CENTRALE

Blocco del congegno di percussione

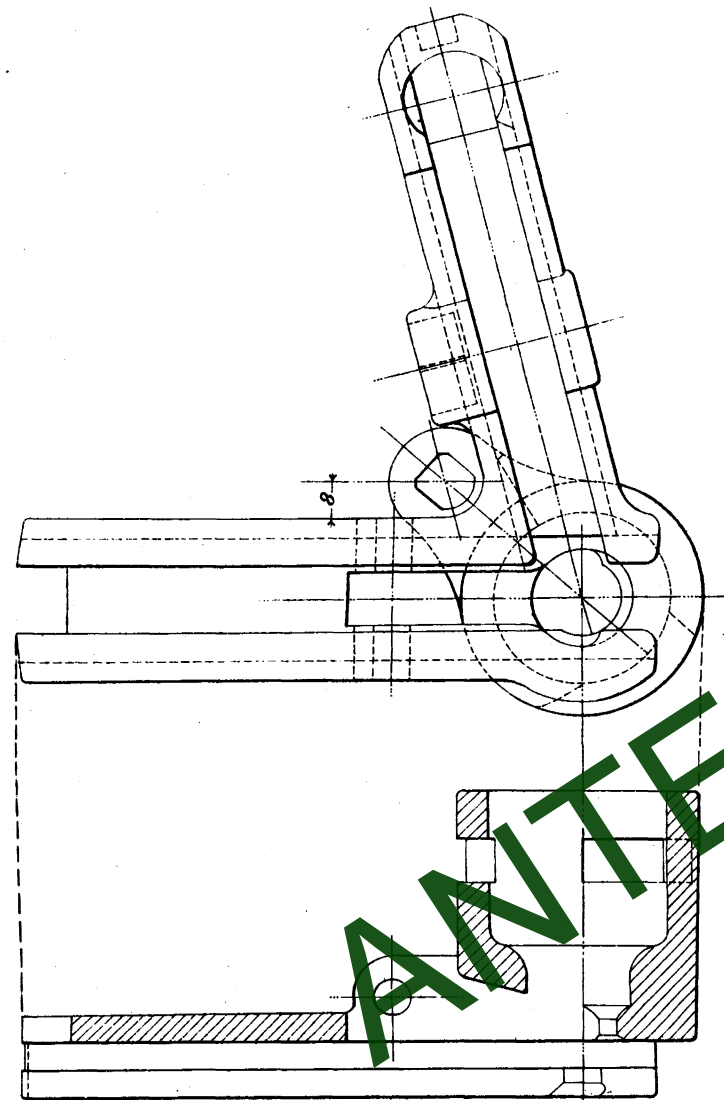

Vivo di culatta con otturatore aperto

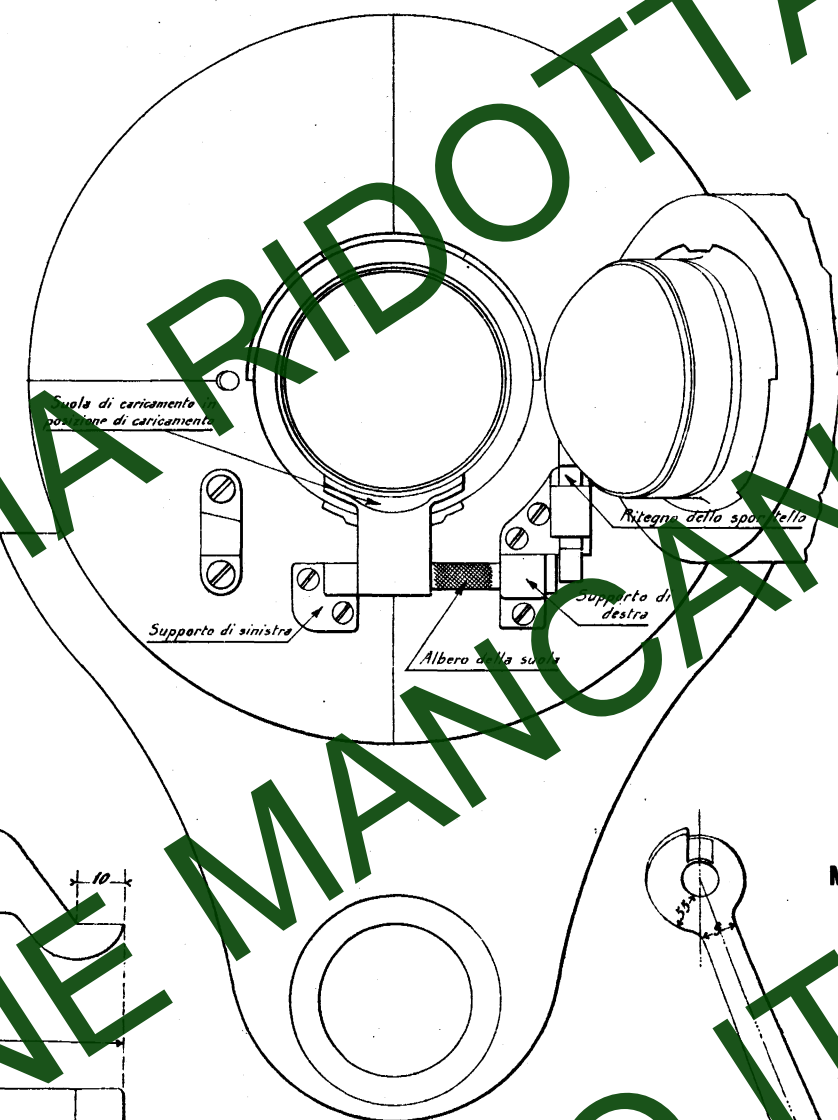

Vivo di culatta con otturatore chiuso

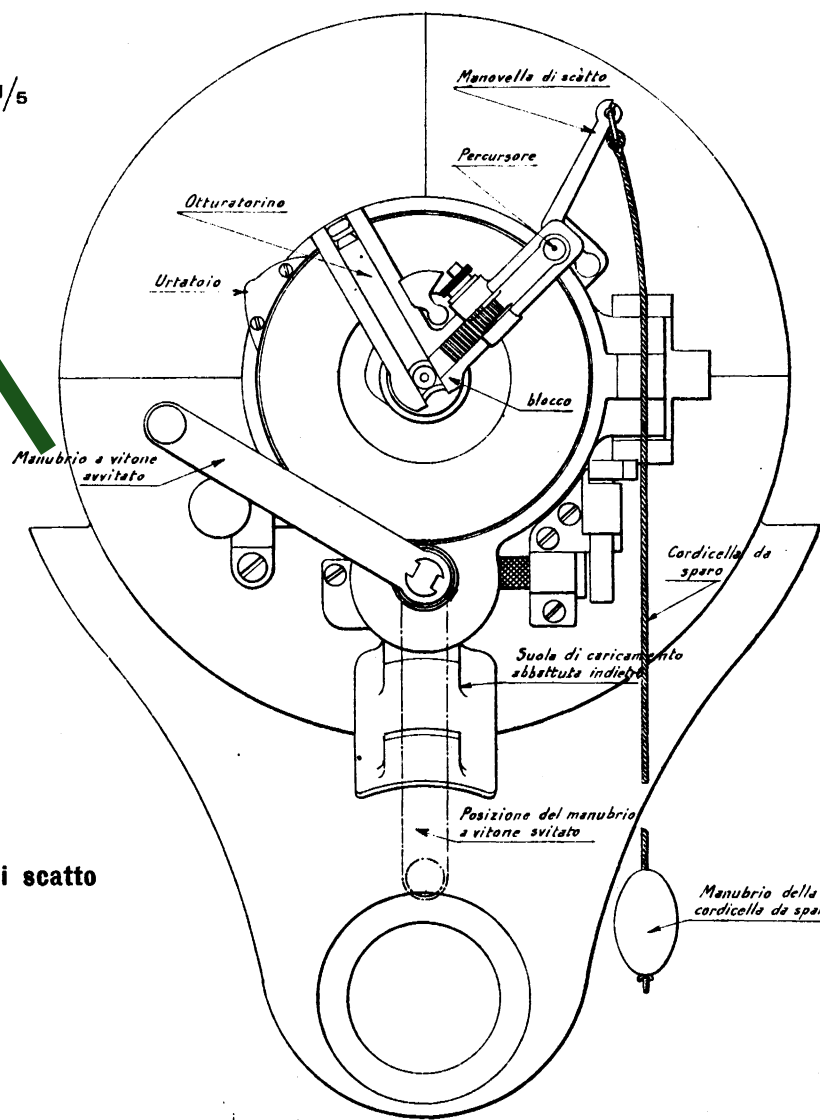

Scala di 1/5

Leva di scatto

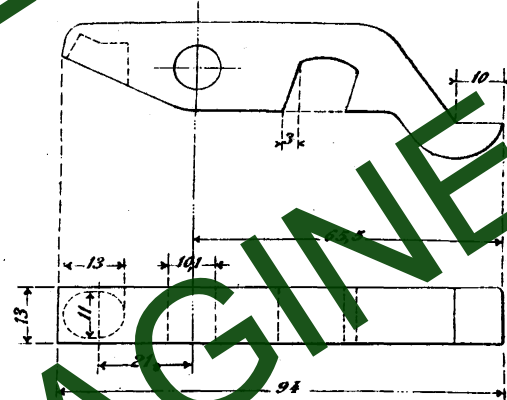

Manovella di scatto

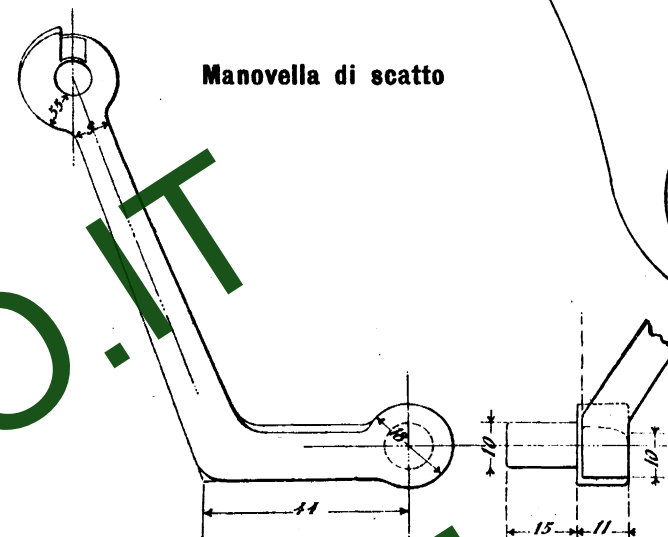

Vitone

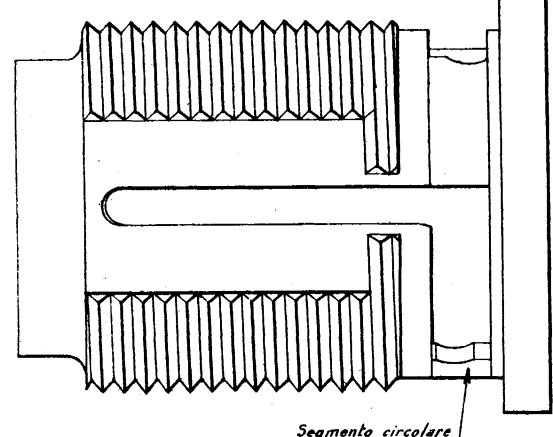

Segmento circolare

Testa a fungo

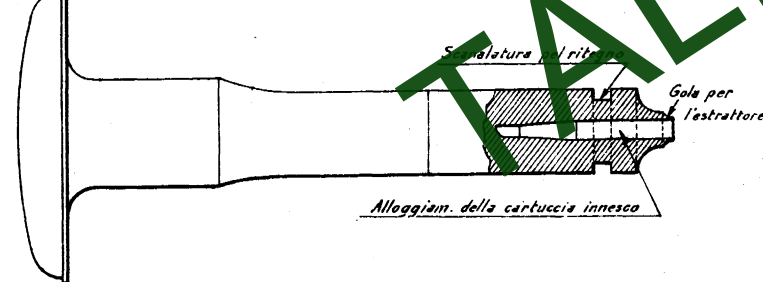

Perno del percussore

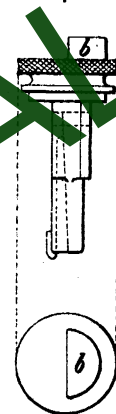

Albero del ritigno di testa a fungo

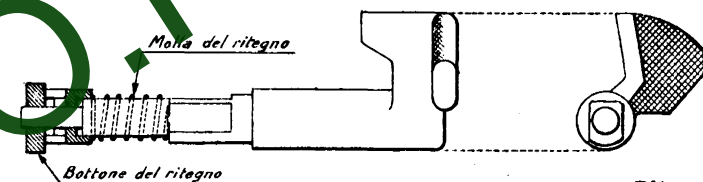

Ritigno di testa a fungo

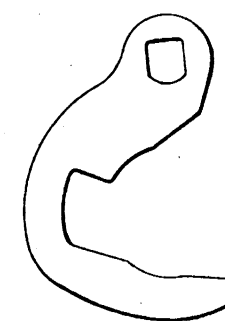

Otturatore

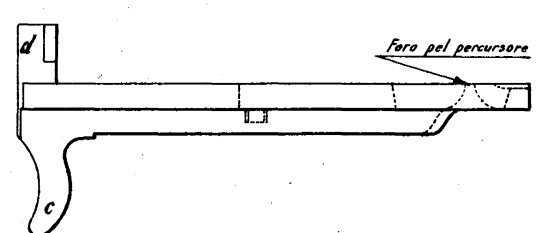

Tirante dello scatto

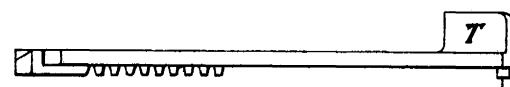

Percussore

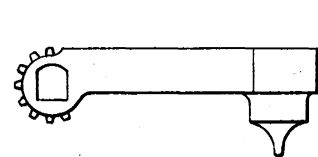

Molla spirale del percuss.



Estrattore

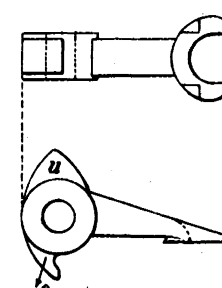

Perno dell'estrattore

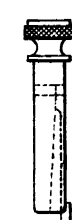

Scala di 1/2 per le parti del congegno a percussione

### CANNONE DA 149 A PER INSTALLAZ. SPECIALI TRASF. A PERCUSSIONE

SCALA DI 1/10

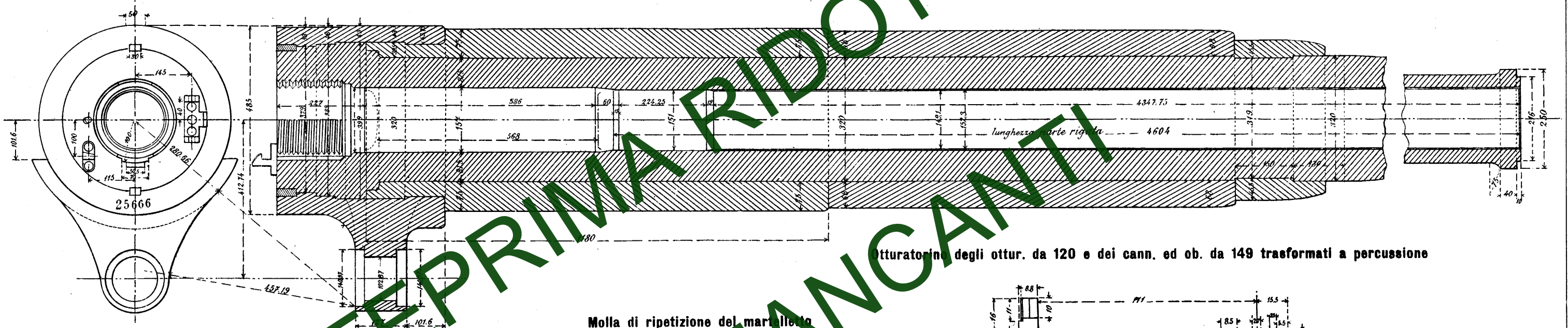

otturatori degli ottur. da 120 e dei cann. ed ob. da 149 trasformati a percussione

Urtatoio dell'otturatore degli ottur. dei cann. ed ob. da 149 trasf. a perc. e da 149 A a perc.

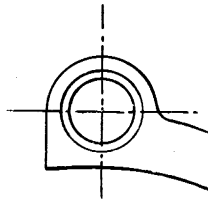

Molla di ripetizione del martelletto

SCALA DI 1/1

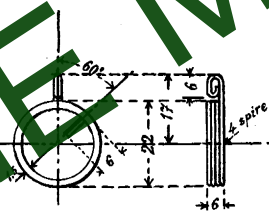

Percussore degli ottur. dei cann. ed ob. da 149 trasf. a percussione

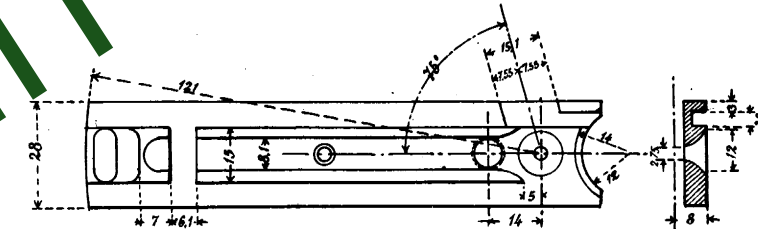
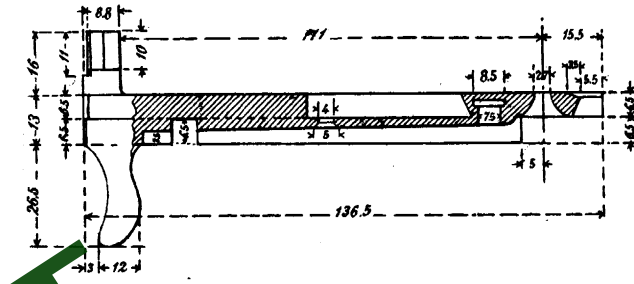

Martelletto degli ottur. da 210 e da 120 e dei cann. ed ob. da 149 trasf. a percussione e da 149 A a percussione

SCALA DI 1/2

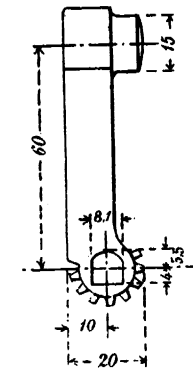
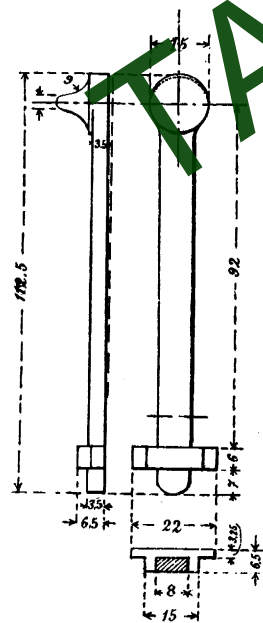
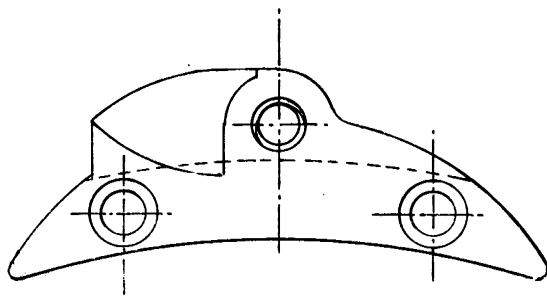

ANTEPRIMA RIDOTTA  
PAGINE MANCANTE  
TALPO.IT



MORTAIO DA 149

Vista di sinistra

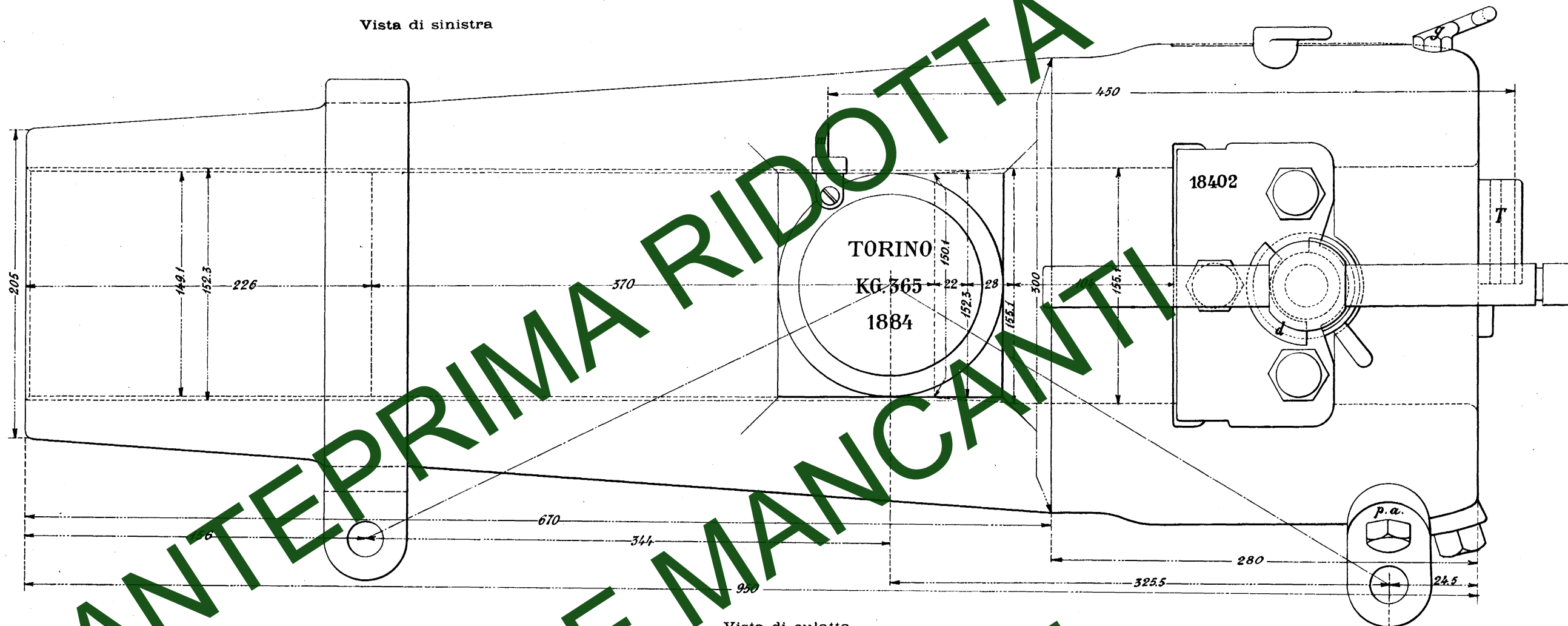

Sezione col piano dell'asse (senza otturatore)

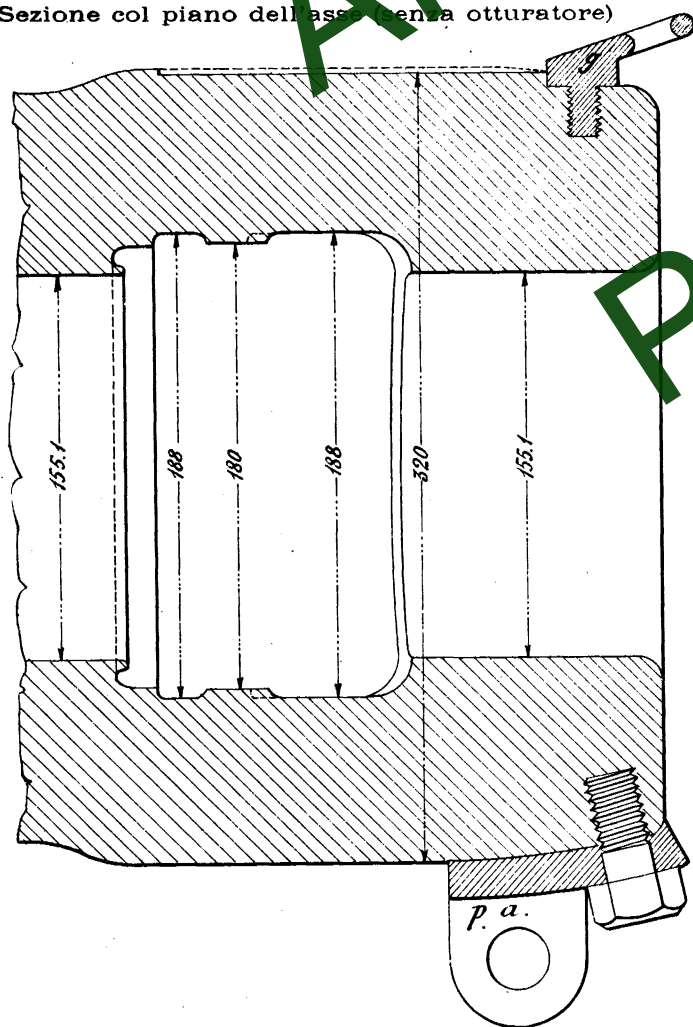

Vista di culatta

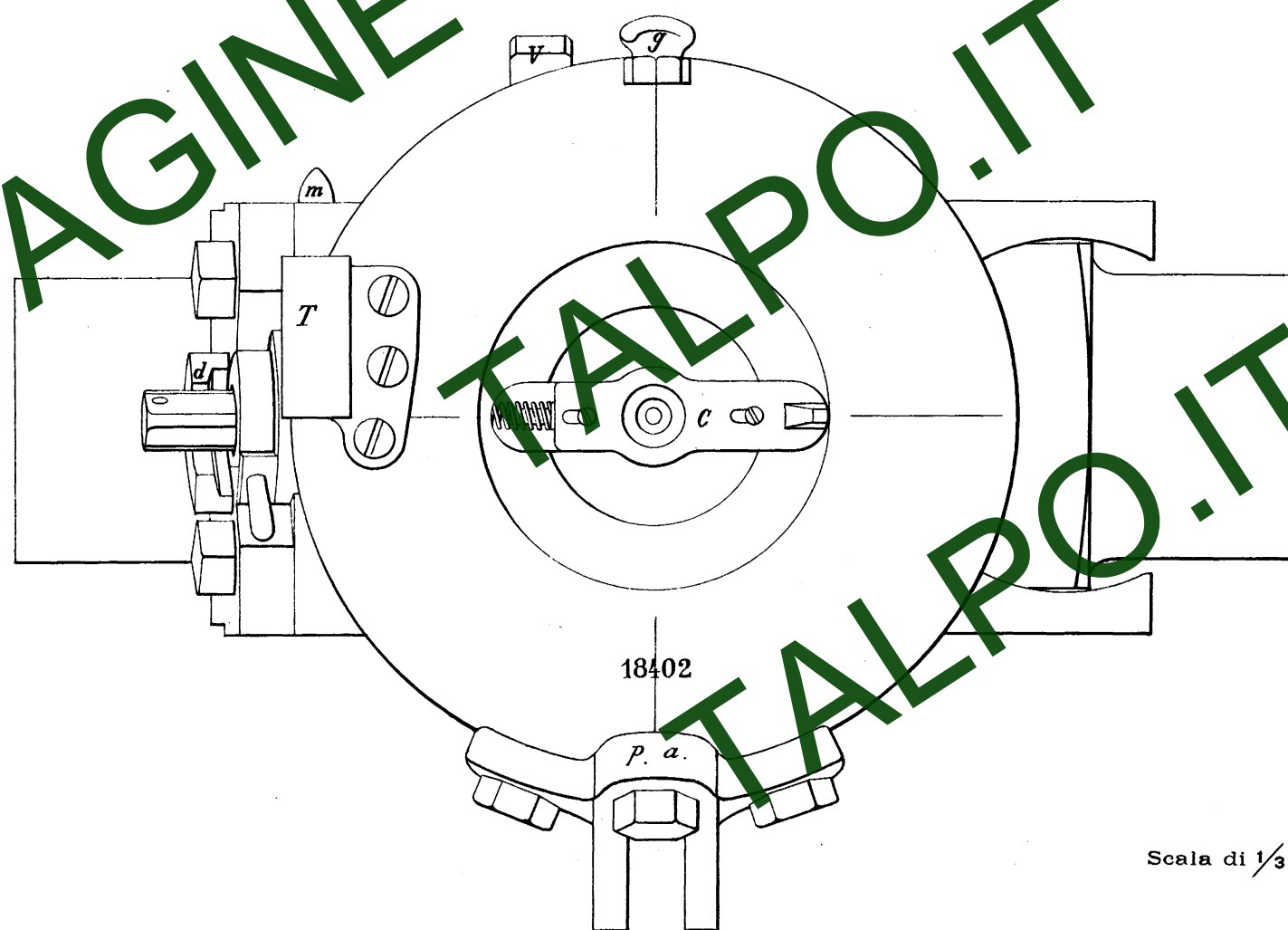

Sezione col piano dell'asse (con otturatore)

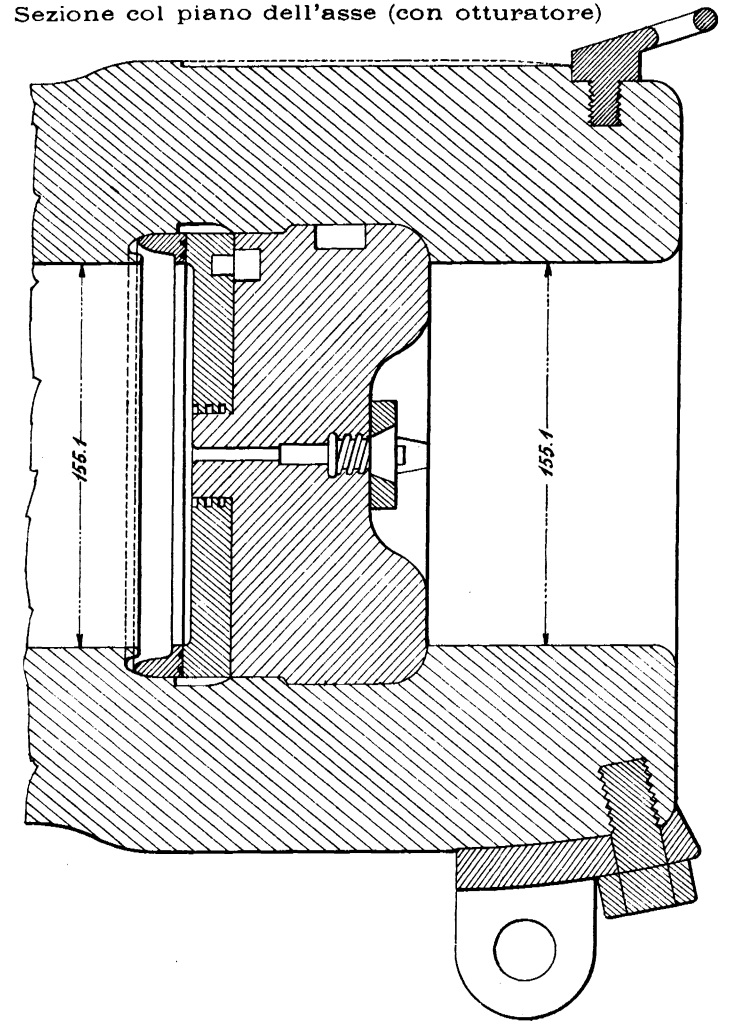

Scala di 1/3



CONGEGNO DI CHIUSURA DEL MORTAIO DA 149.

Sezione col piano degli assi (con otturatore)

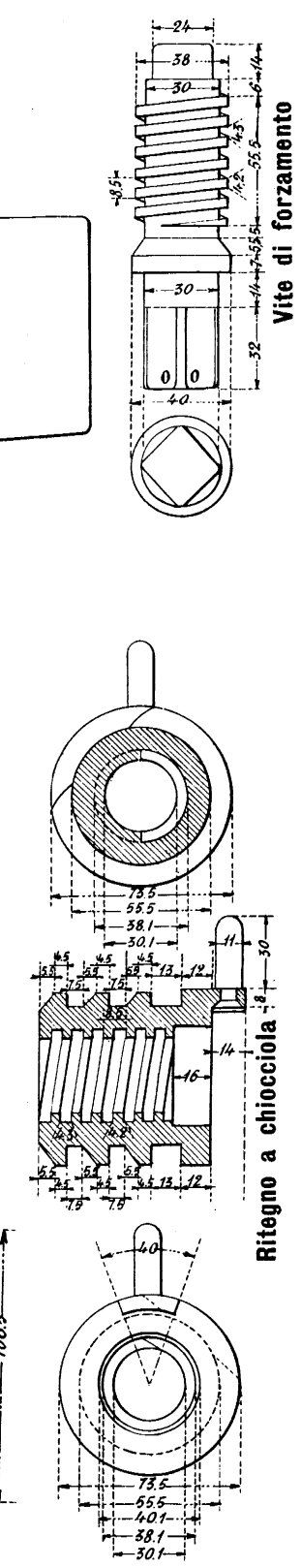
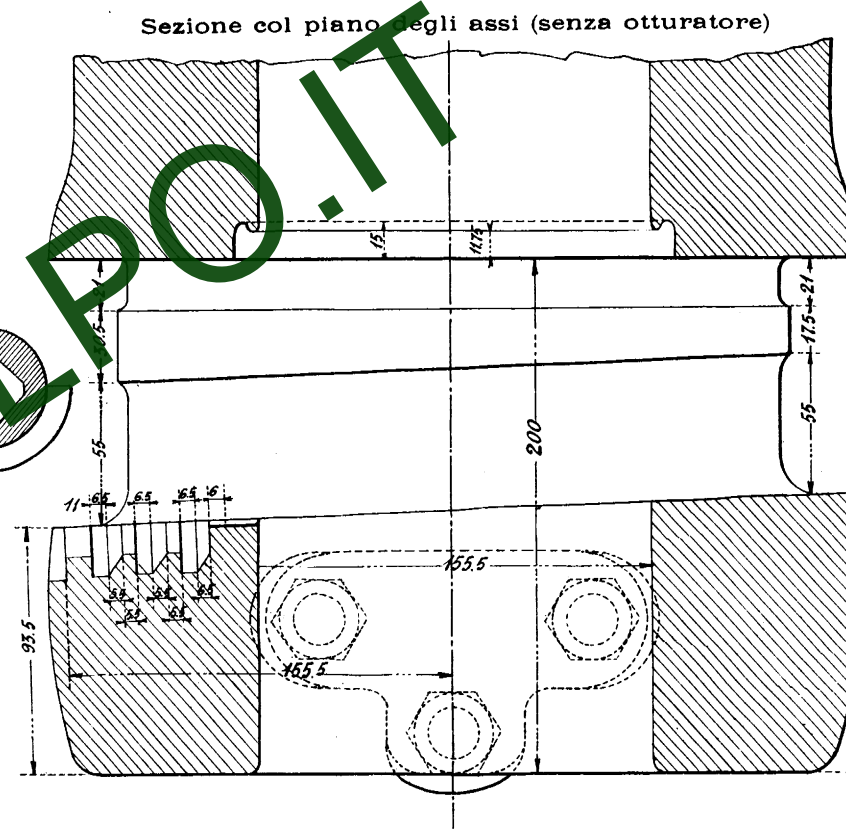
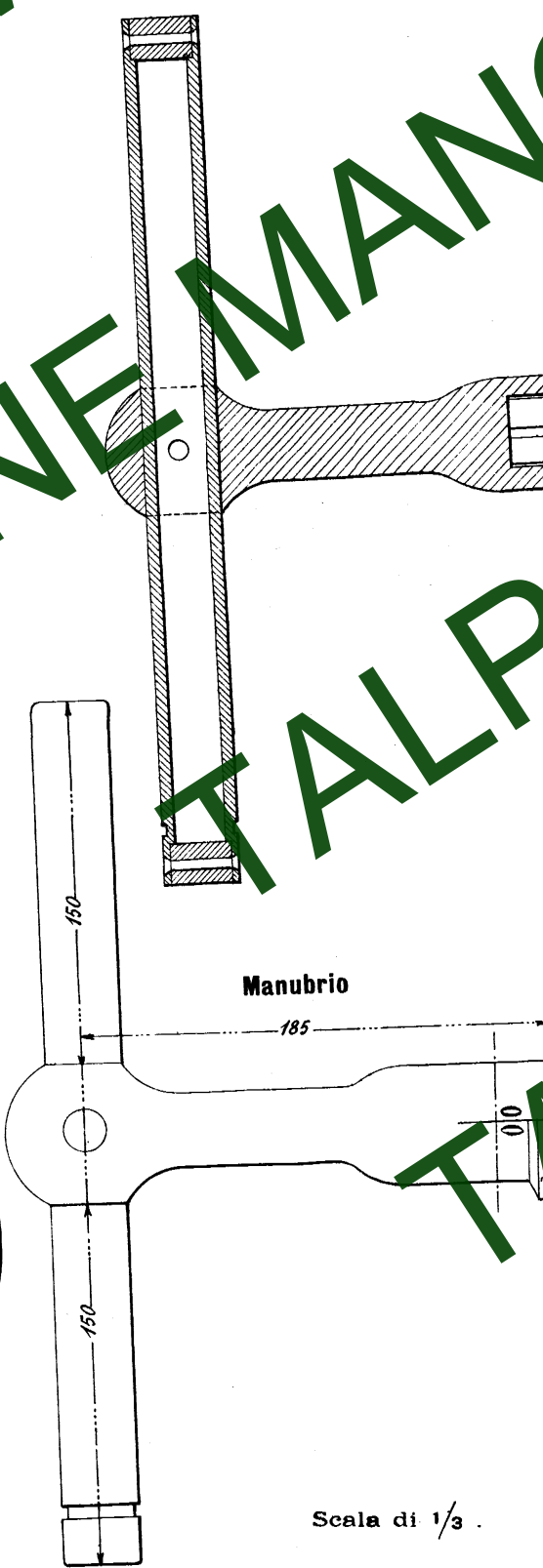
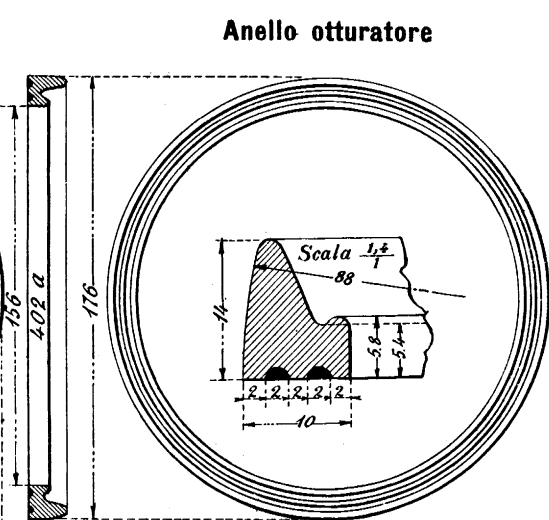
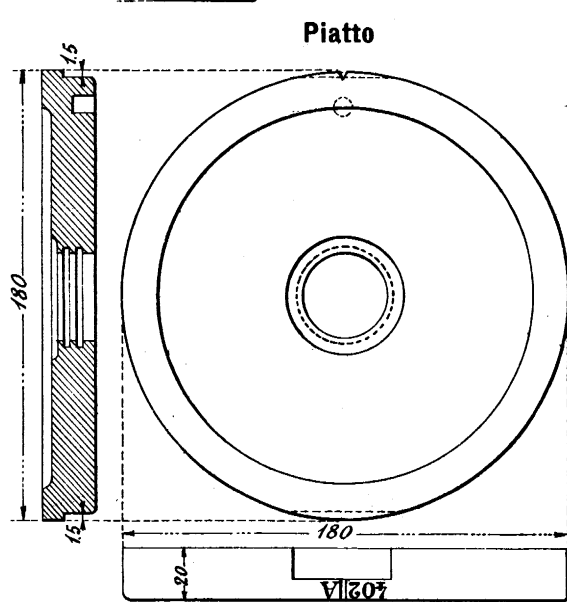
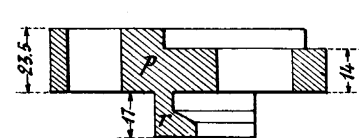
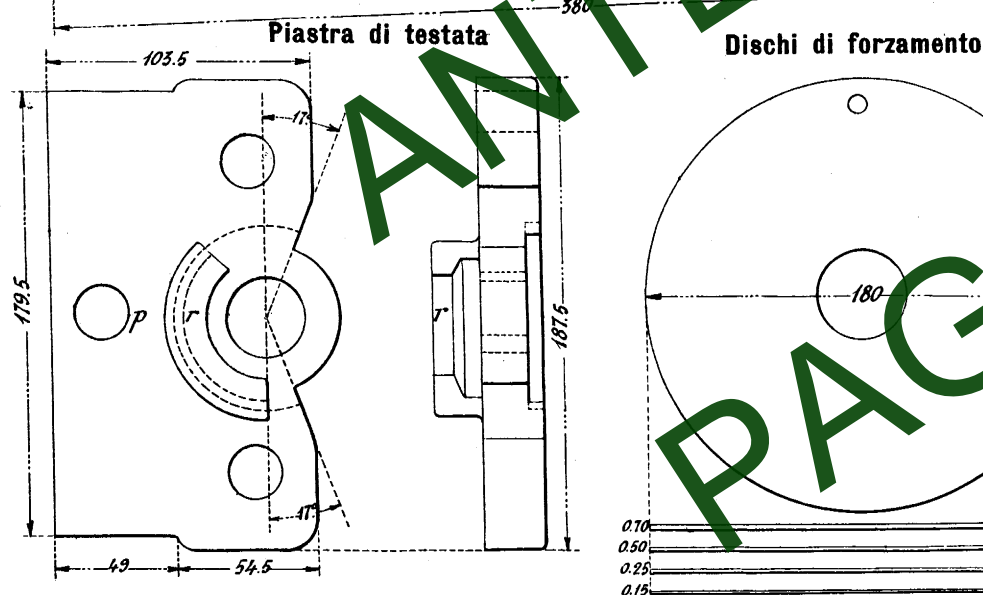
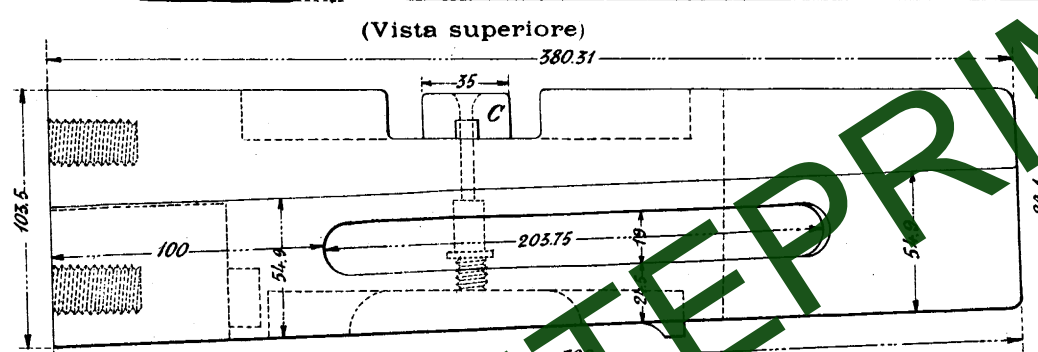
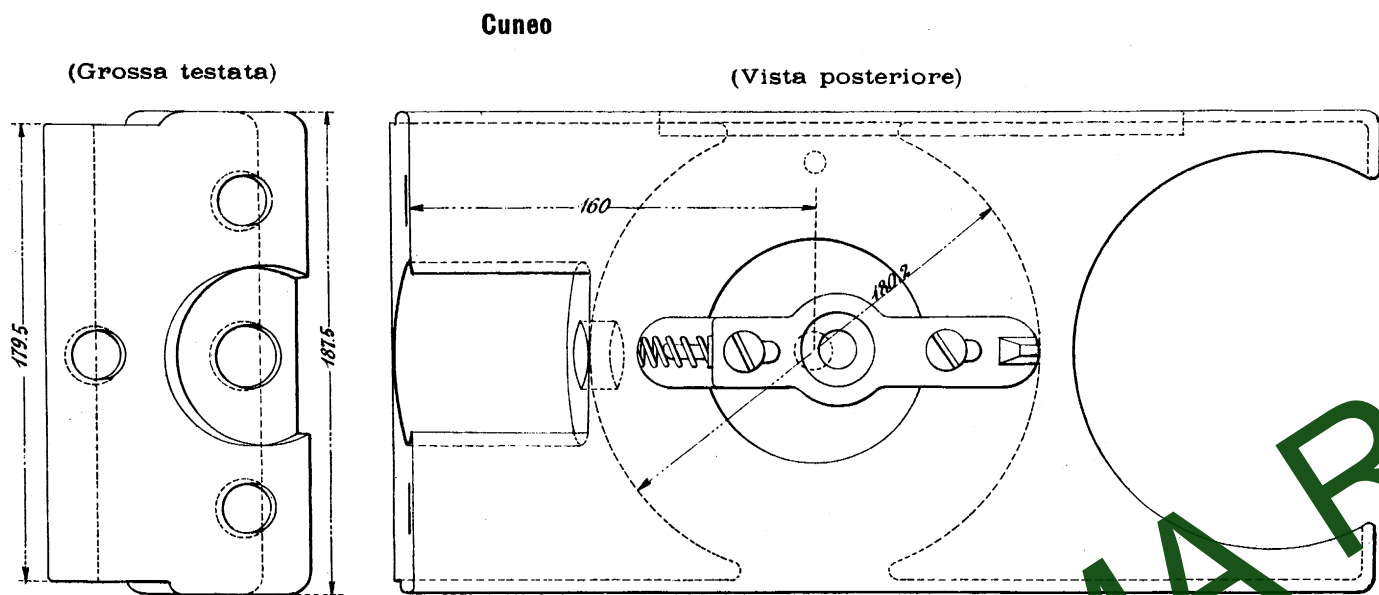

Scala di 1/3



Successive posizioni del ritegno a chiocciola nella chiusura della culatta del mortaio da 149

I Posizione

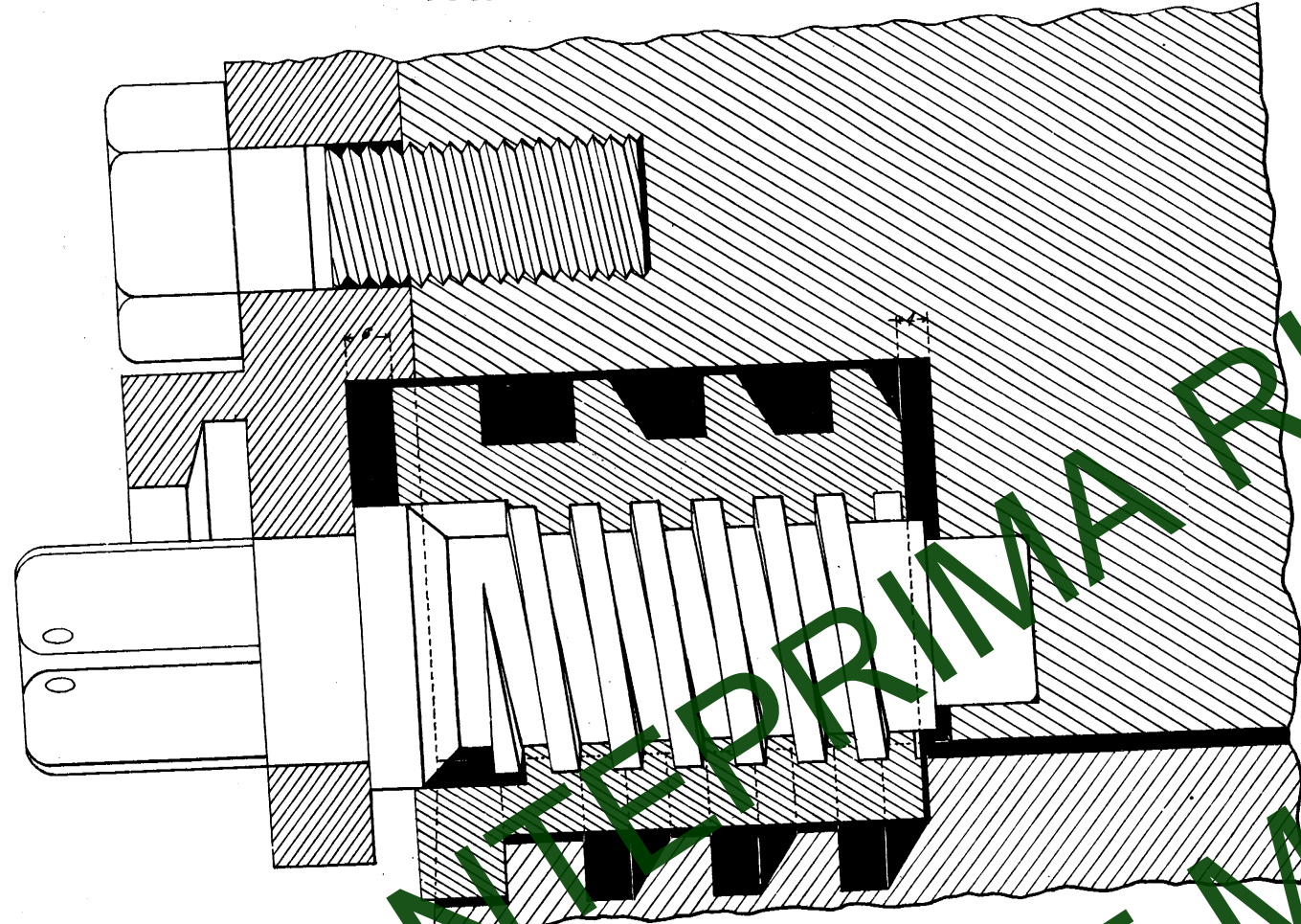

II Posizione

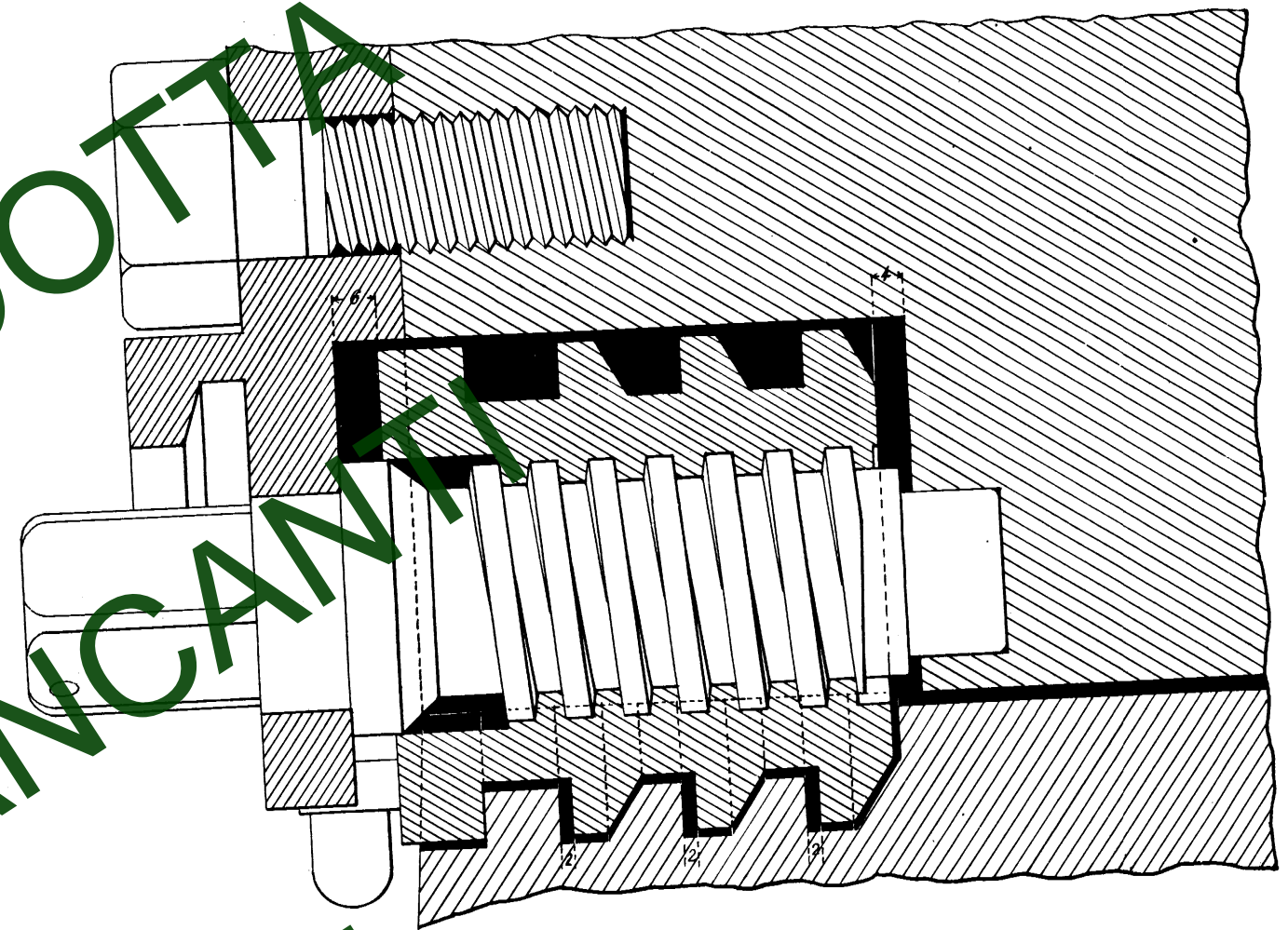

III Posizione

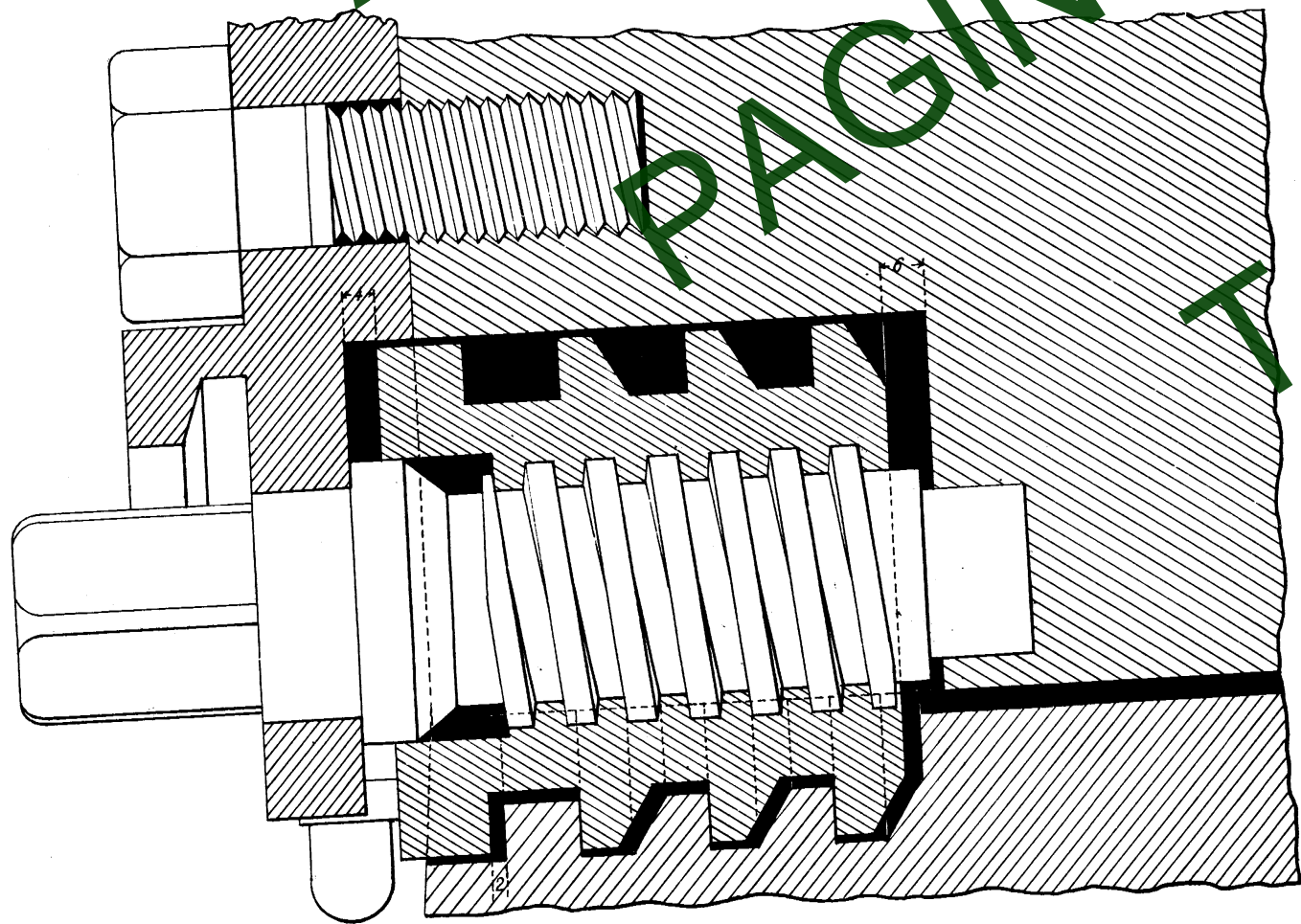

IV Posizione

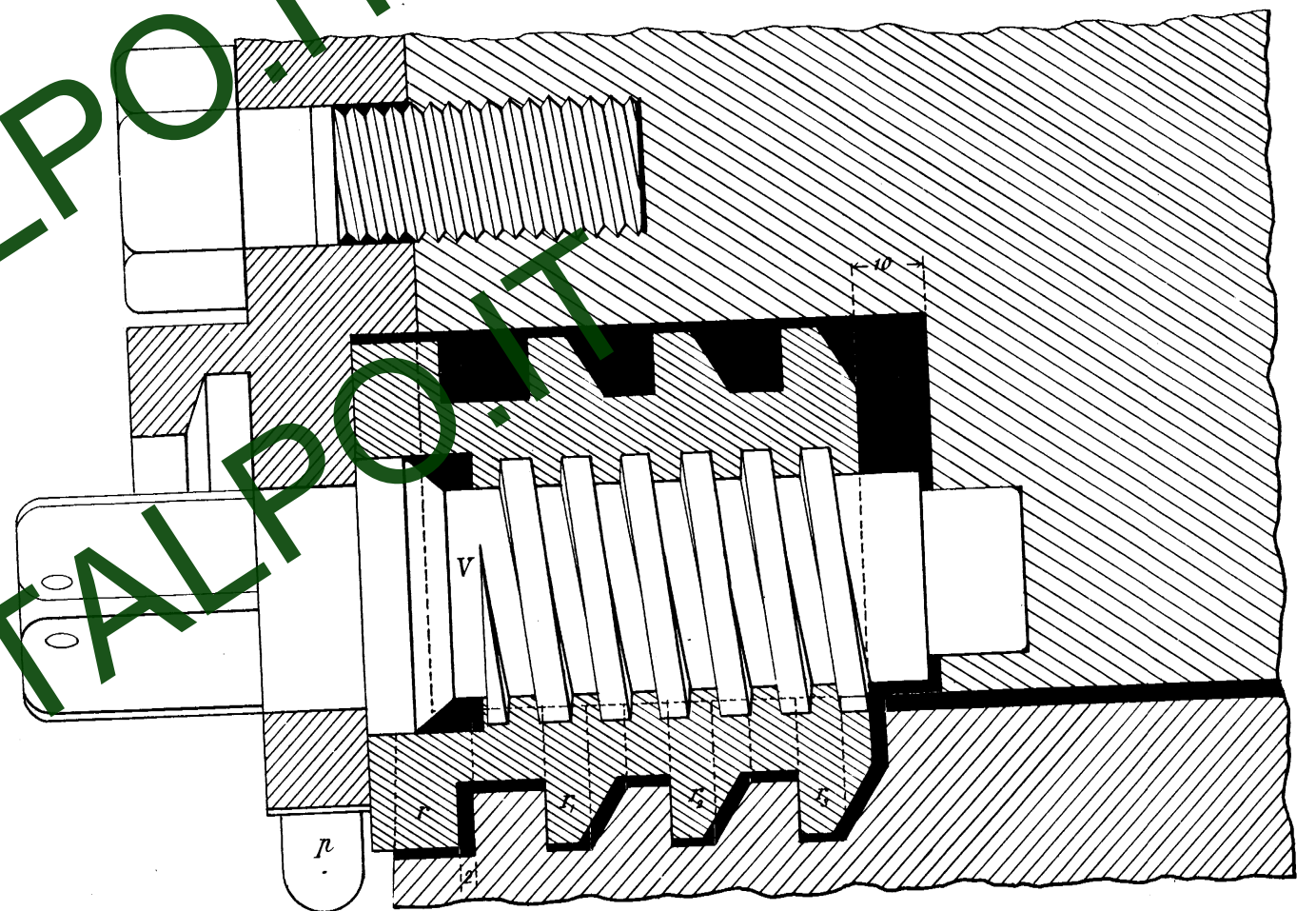

Scala di 1/1

ANTEPRIMA RIDOTTA  
PAGINE MANGANTI  
TALPO.IT



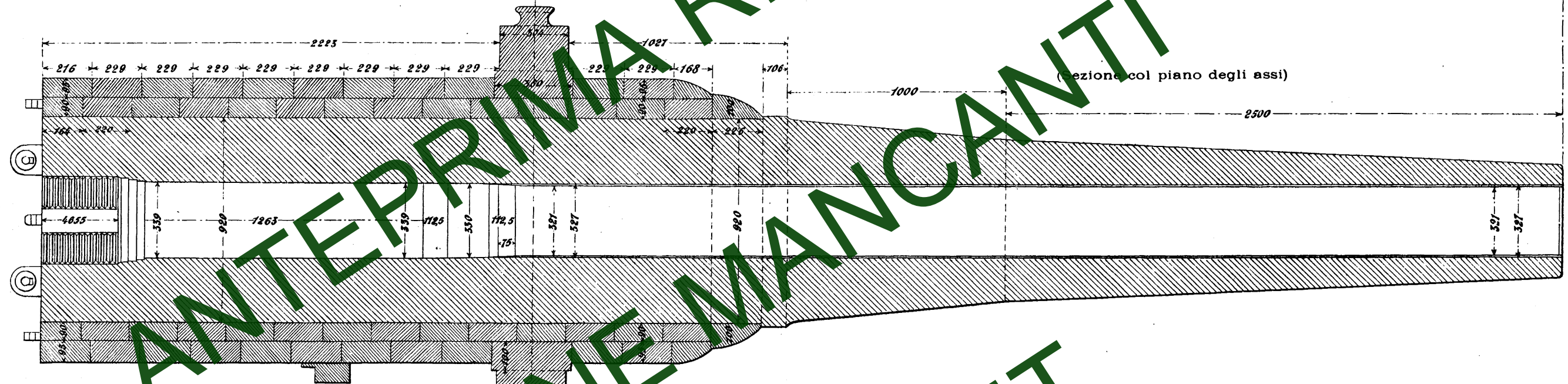
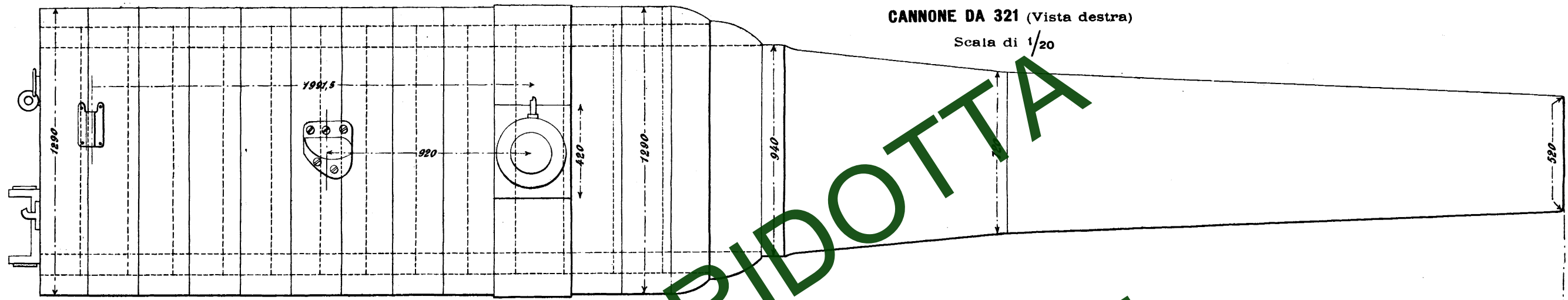

Vitone

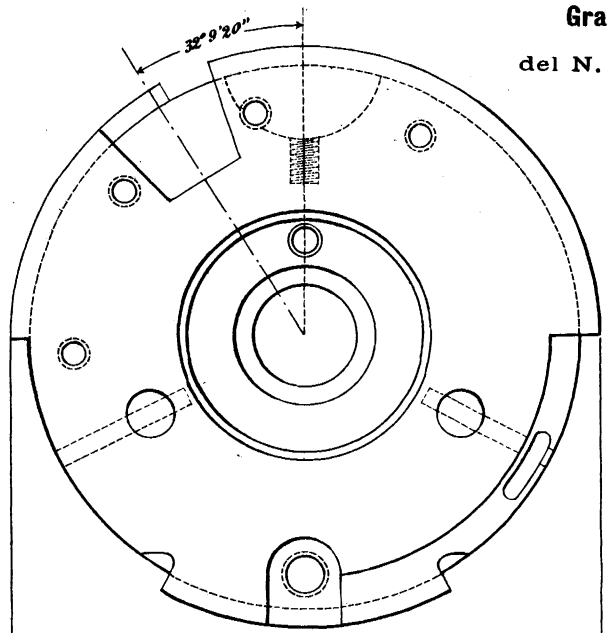

Grano a focone

del N. 14 del N. 15

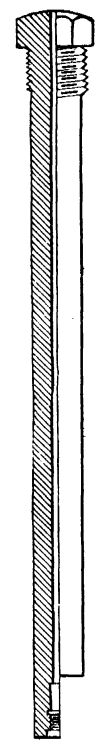

Ritegno di anello

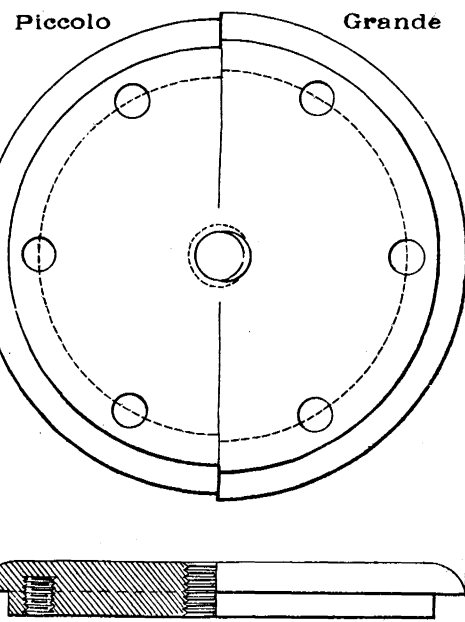

OTTURATORI DA 321

Scala di 1/5

Anello otturatore

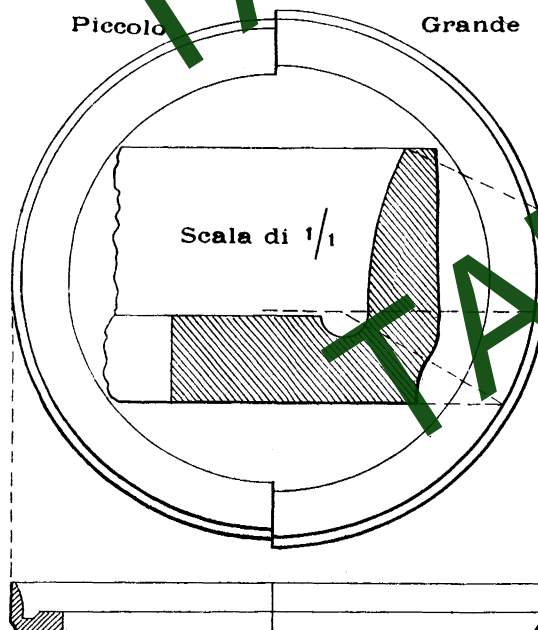

Disco d'acciaio

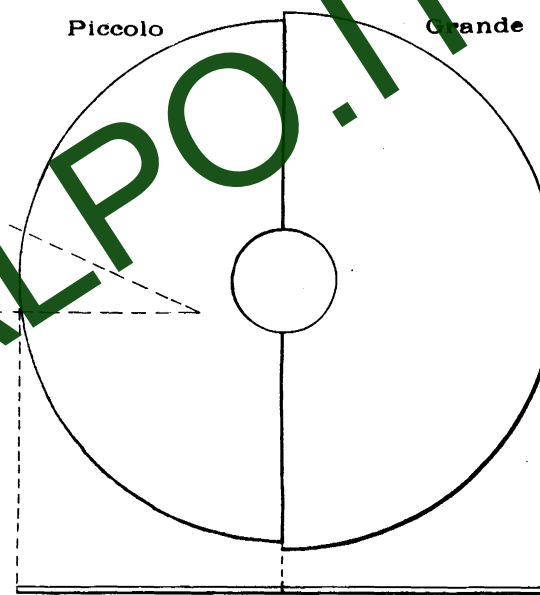

Testa a codolo

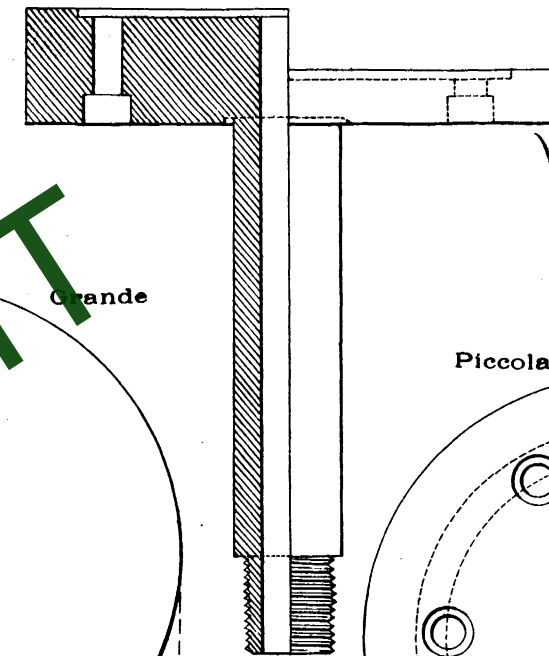

Piccola

Grande

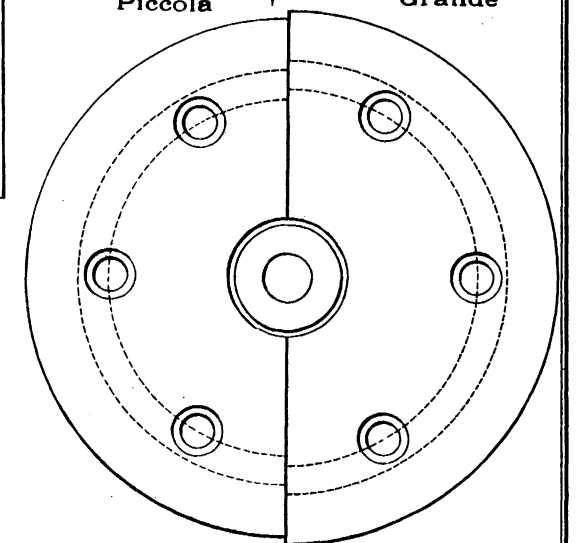



CANNONE DA 321 (Vista di culatta)  
e mensola reggi otturatore

(Vista inferiore)

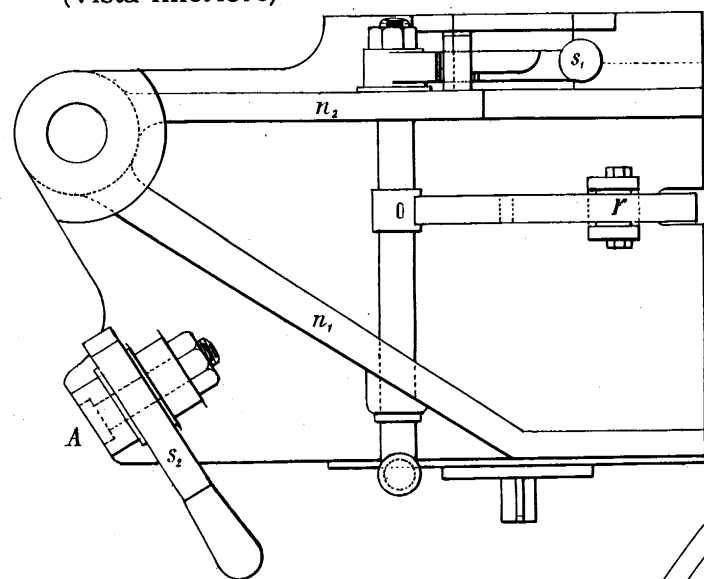

(Vista inferiore)

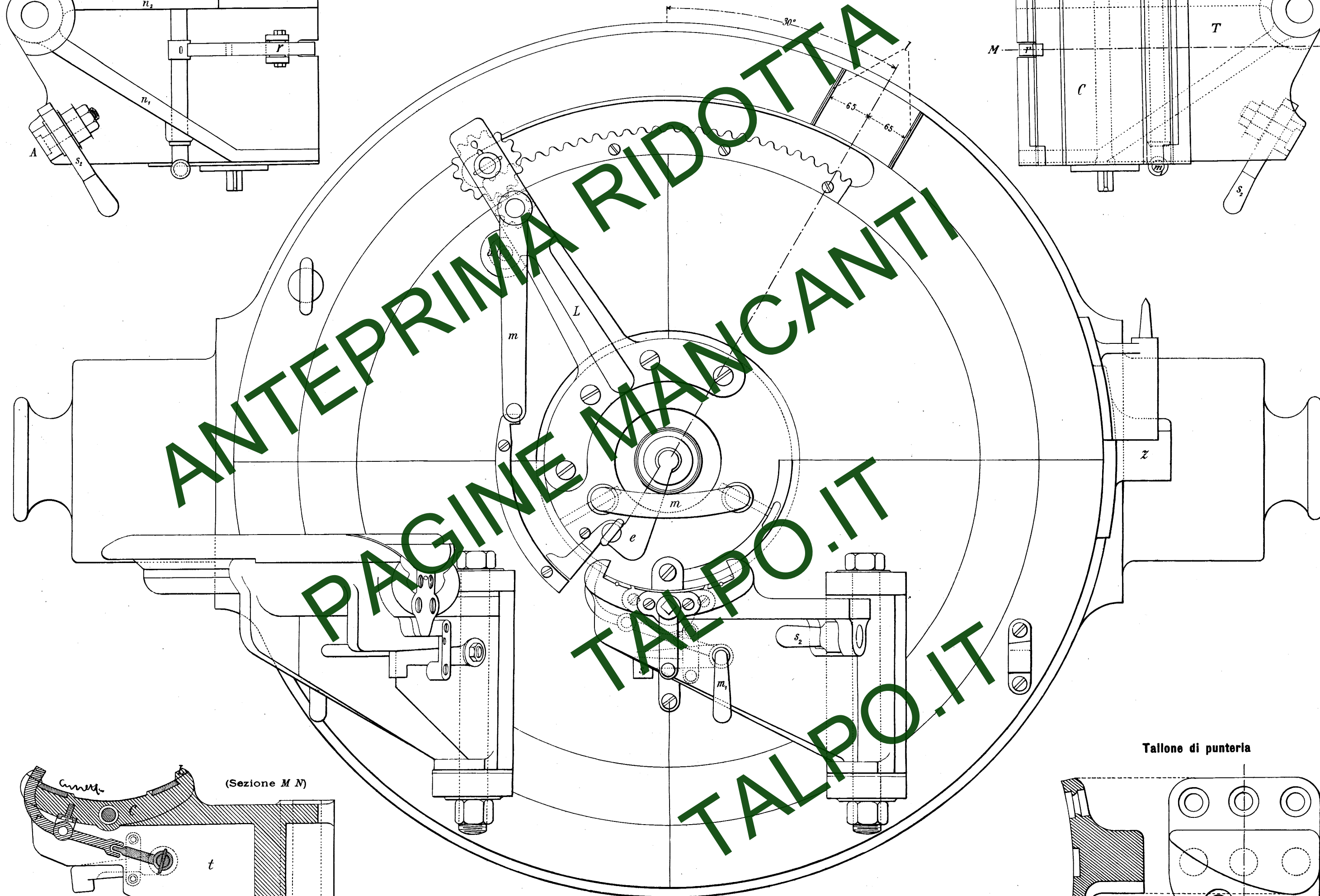
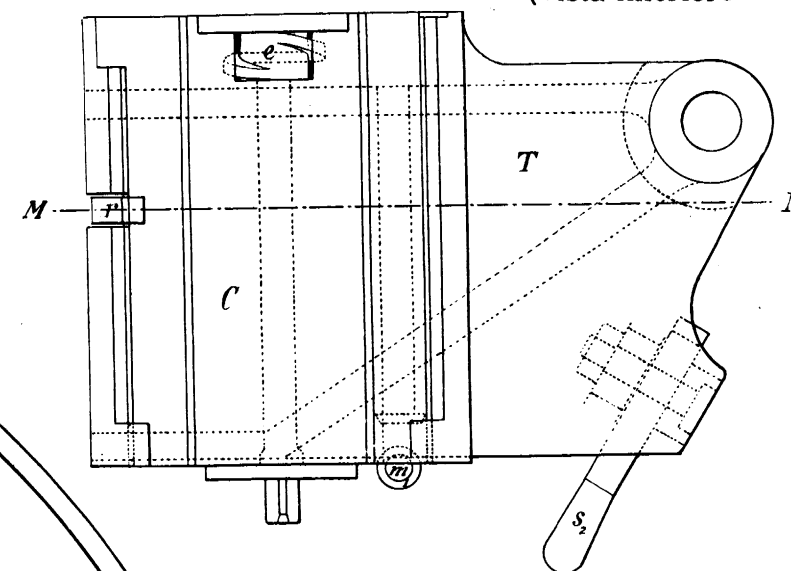

ANTEPRIMA RIDOTTA  
PAGINE MANCANTI  
TALPO.IT

Tallone di punteria

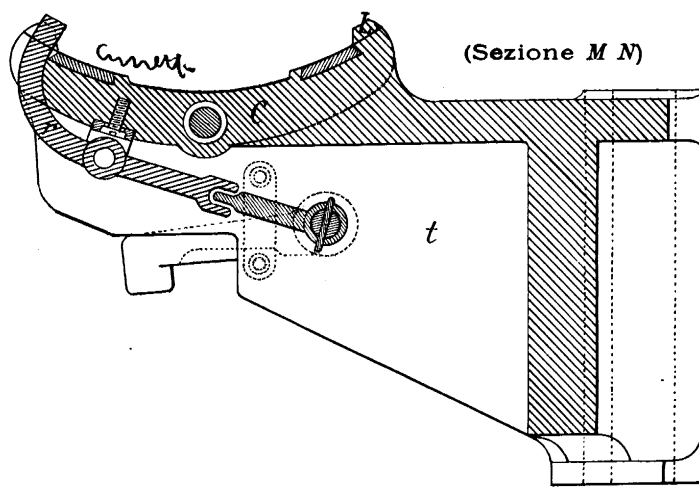
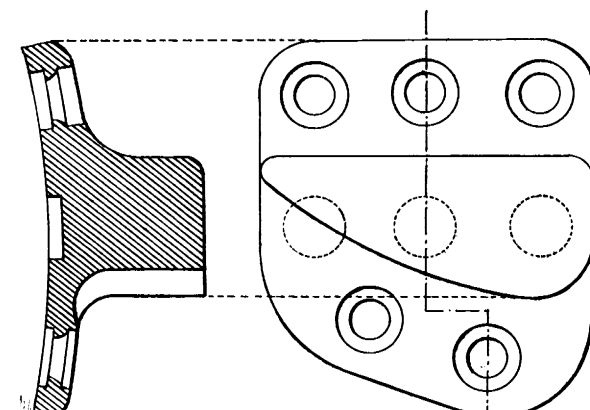

Scala di 1/5



Sezione in culatta con un piano verticale  
(Otturatore sulla mensola reggi-vitone)

CANNONE DA 321

Sezione in culatta con un piano verticale  
(Otturatore svitato)

Scala di 1/5

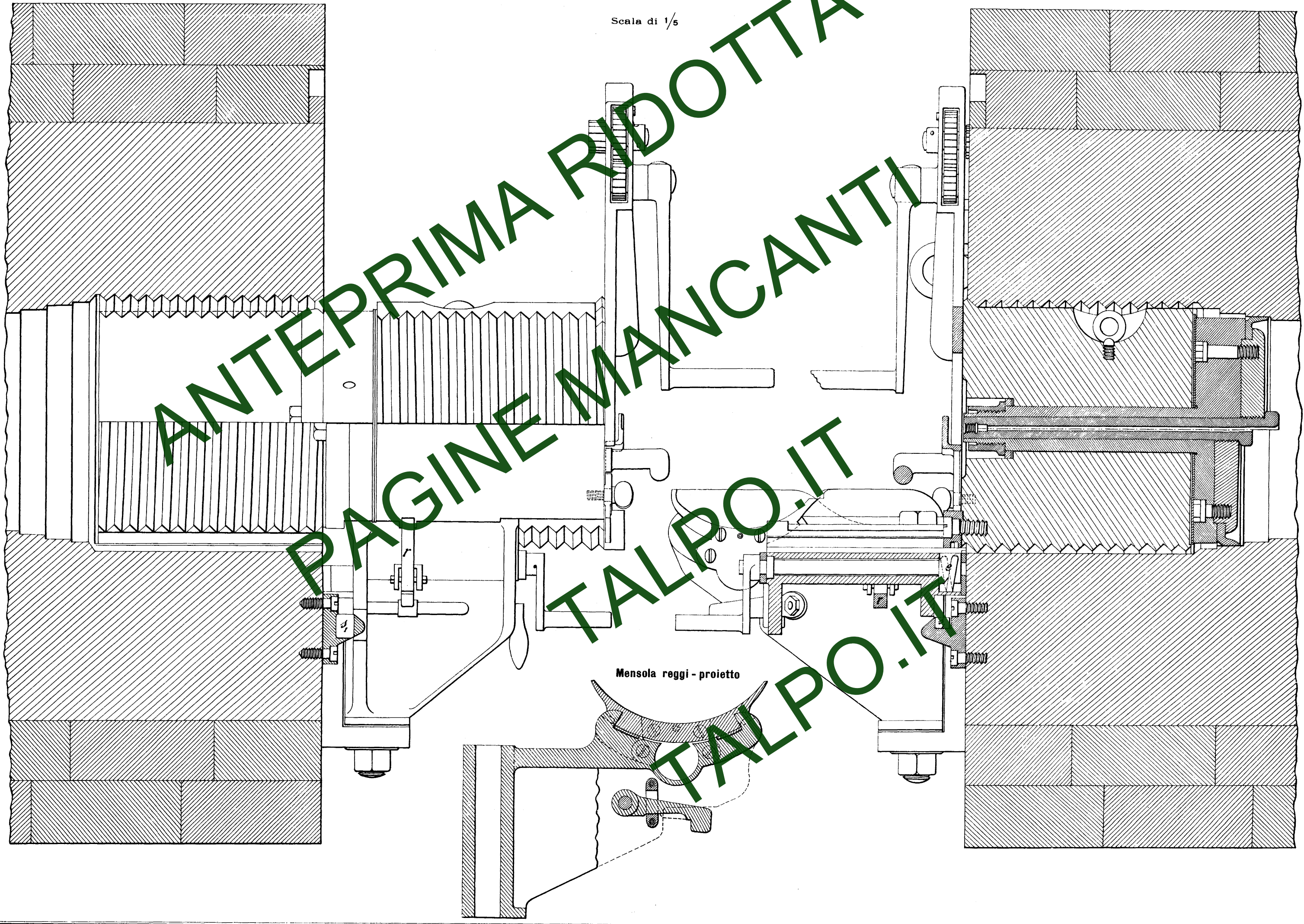

ANTEPRIMA RIDOTTA  
PAGINE MANCANTI  
TALPO.IT



CANNONI DA 240, lungo e corto (Sezione col piano dell'asse)

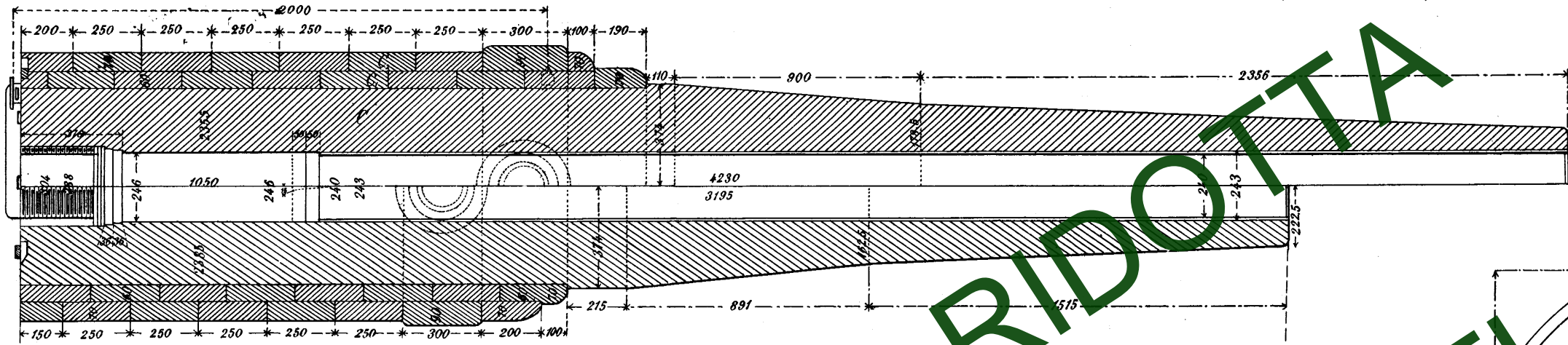

(Vista di culatta)

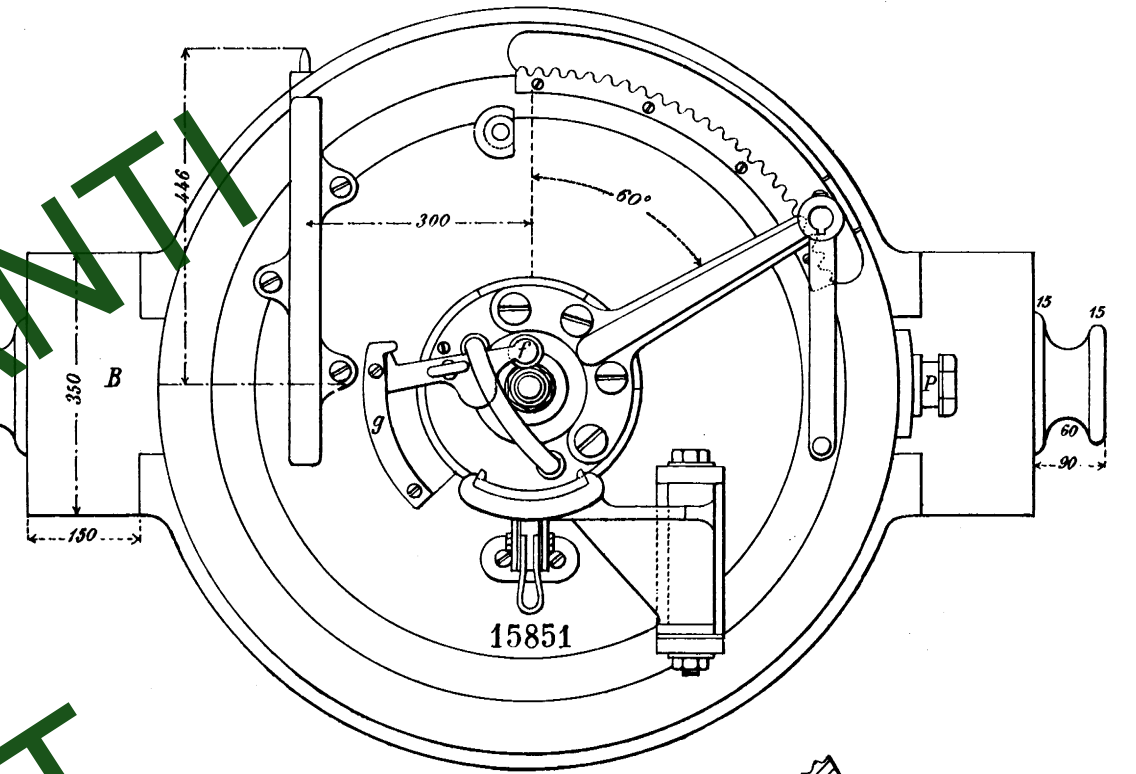

CANNOE DA 240, corto (Vista superiore)

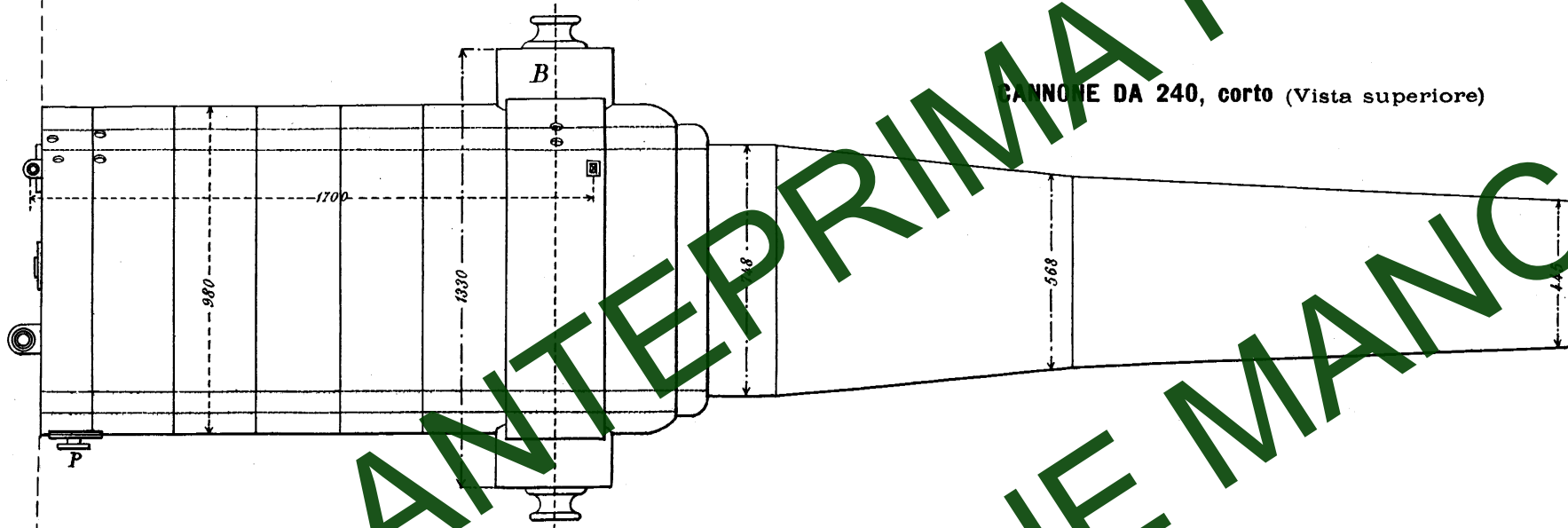

CANNONI DA 240, lungo e corto (Vista destra)

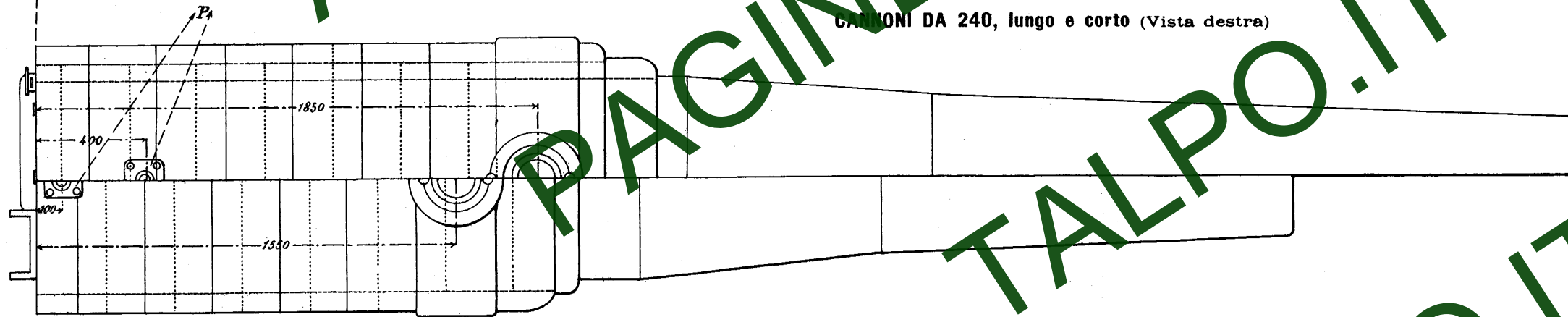

Mensola (Vista di sopra)

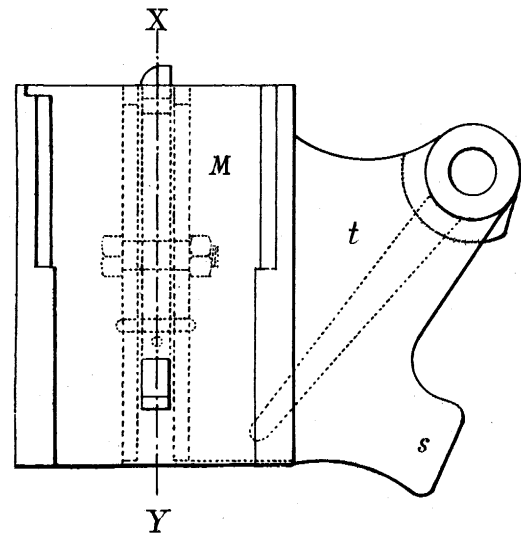

Maglia di scatto

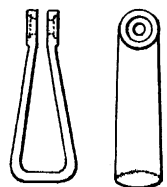

Molla di scatto

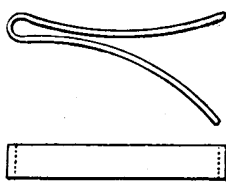

Scatto

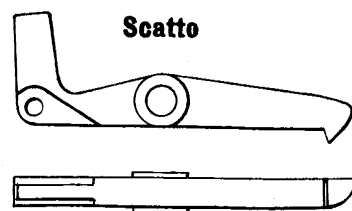

Mensola (Vista di dietro)

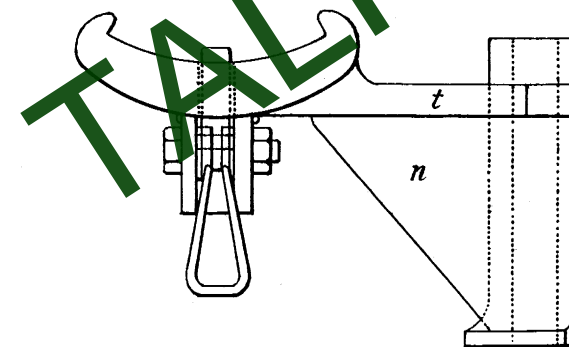

Scala di 1/5

Mensola completa

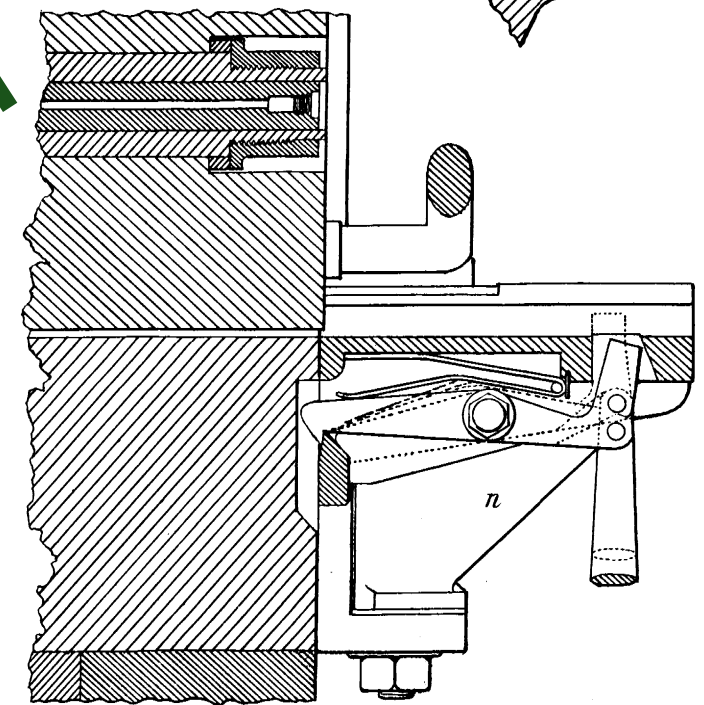

Sezione XY

ANTEPRIMA RIDOTTA  
 PAGINE MANCANTI  
 TALPO.IT



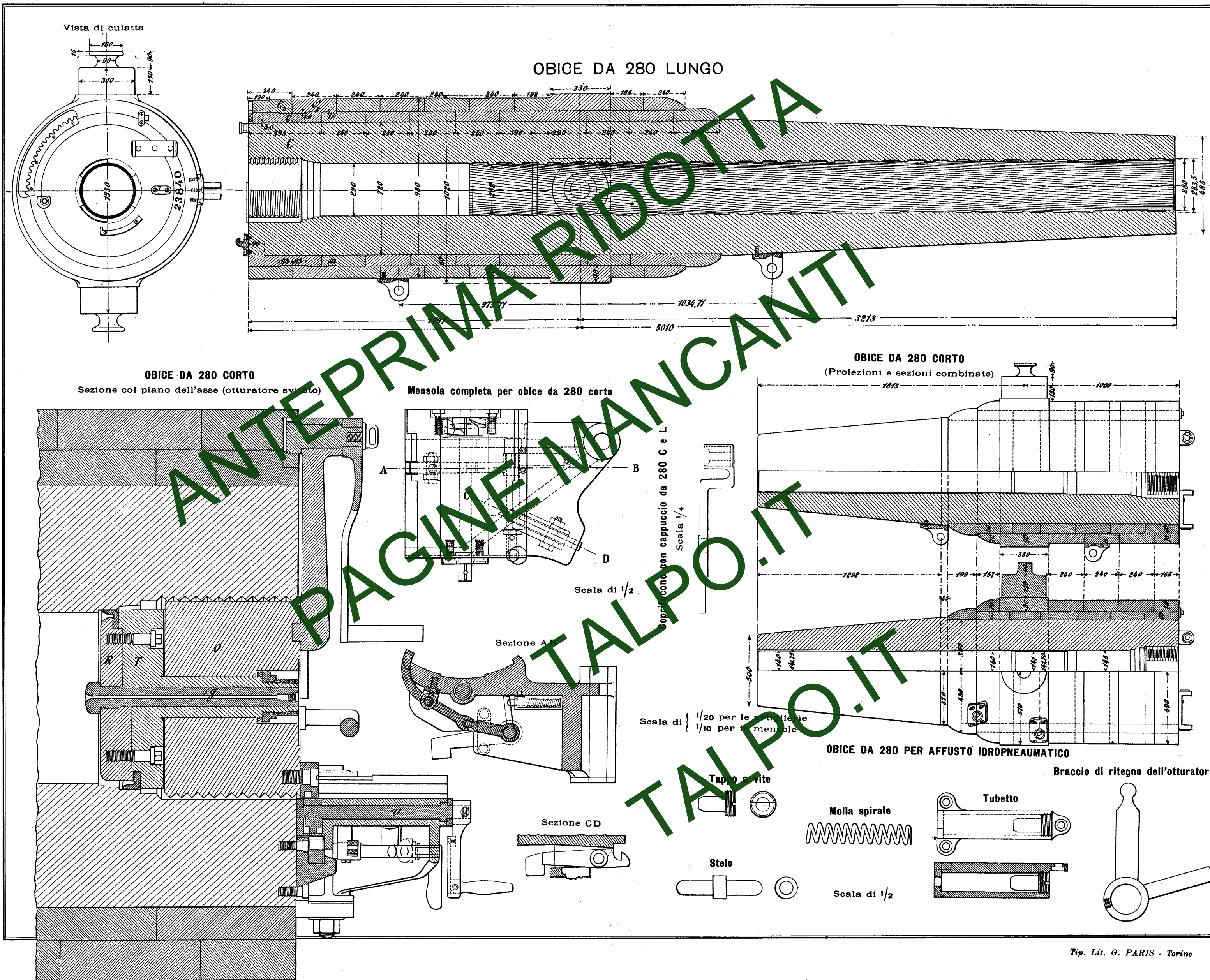

ANTEPRIMA RIDOTTA  
 PAGINE MANCANTI  
 TALPO.IT



Obice 280 A

Obice 280 B

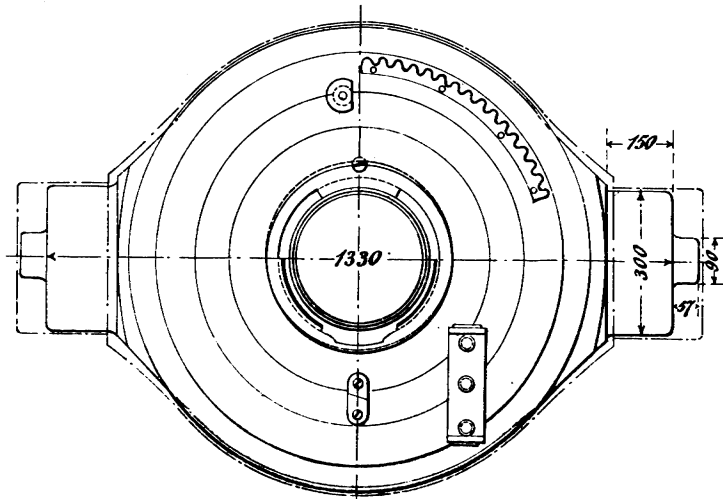
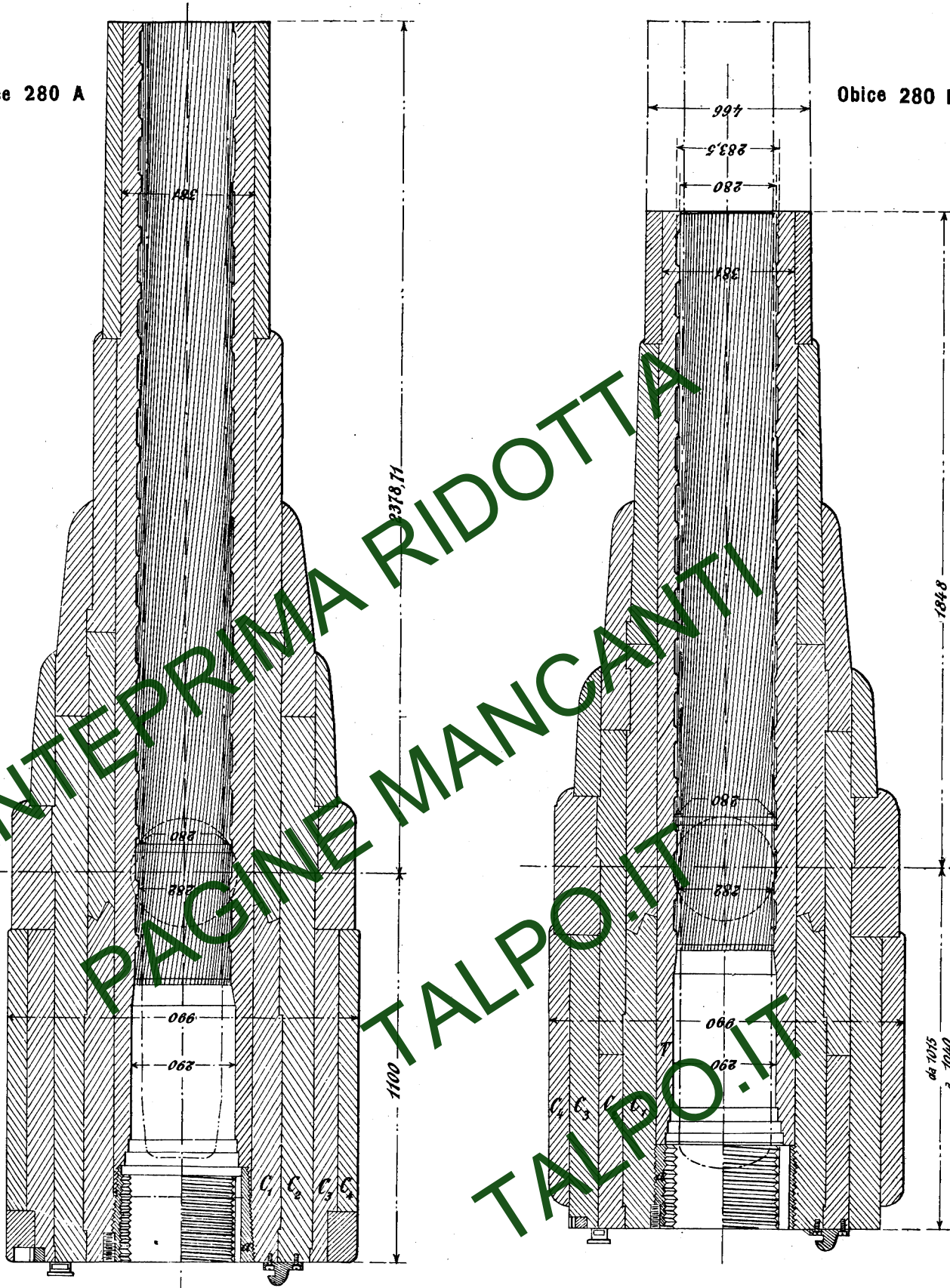

CANNONE DA 400  
Scala di 1/30

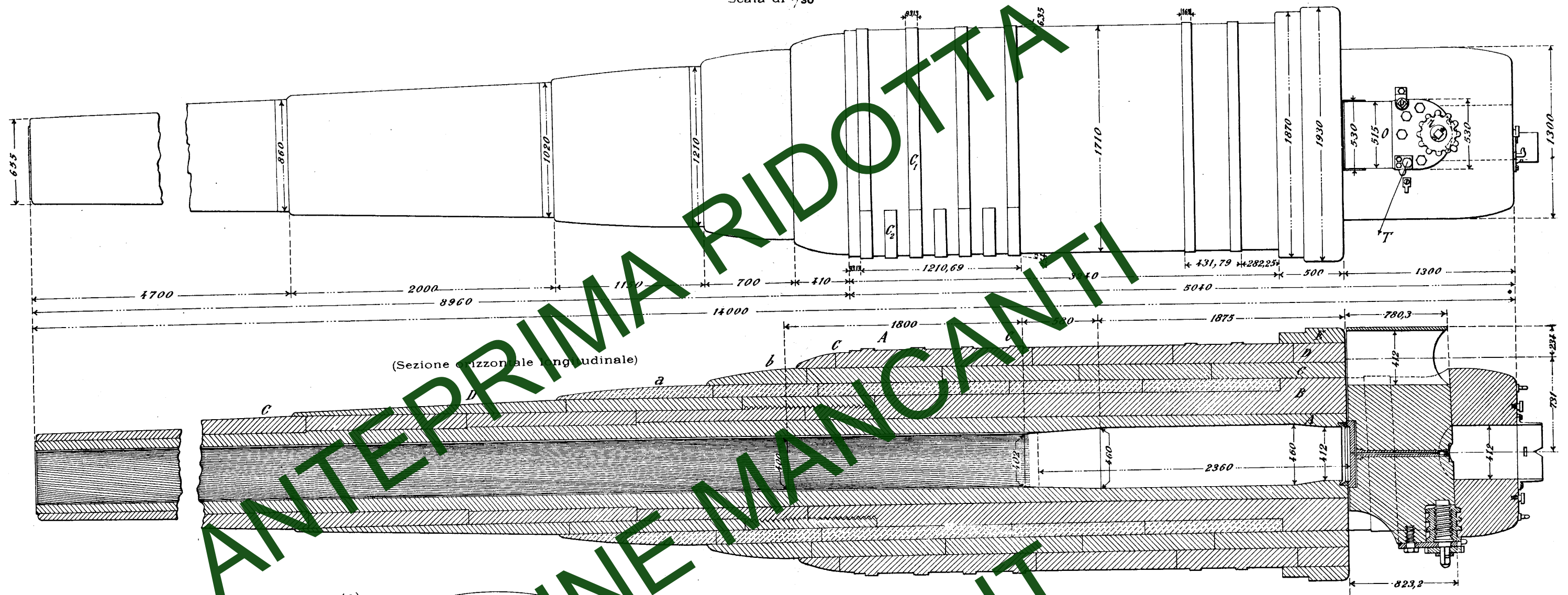

Visto di dietro (con otturatore aperto)

(Sezione verticale longitudinale in culatta)  
Otturatore chiuso

Anello otturatore  
Scala di 1/2

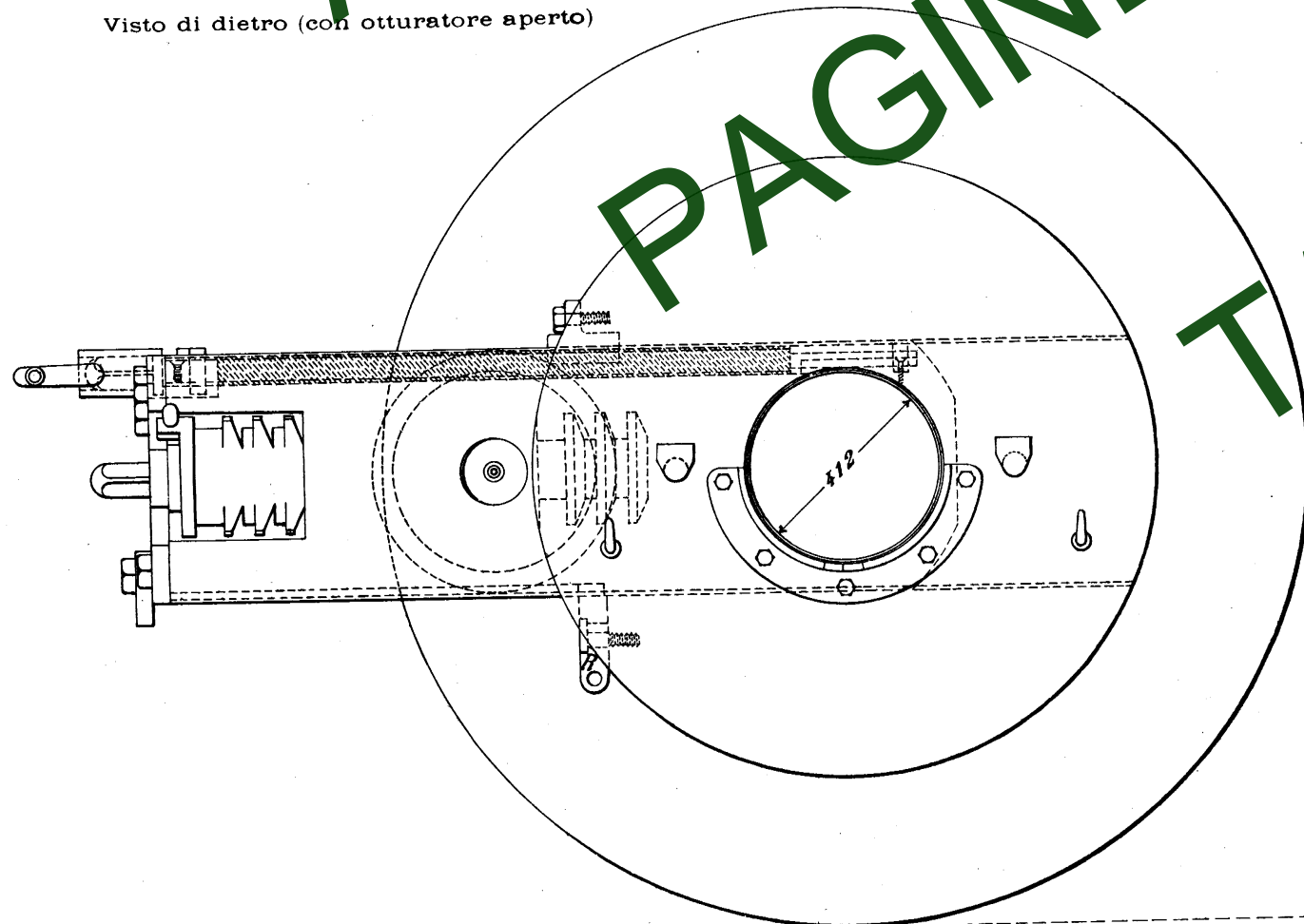

Scala di 1/15

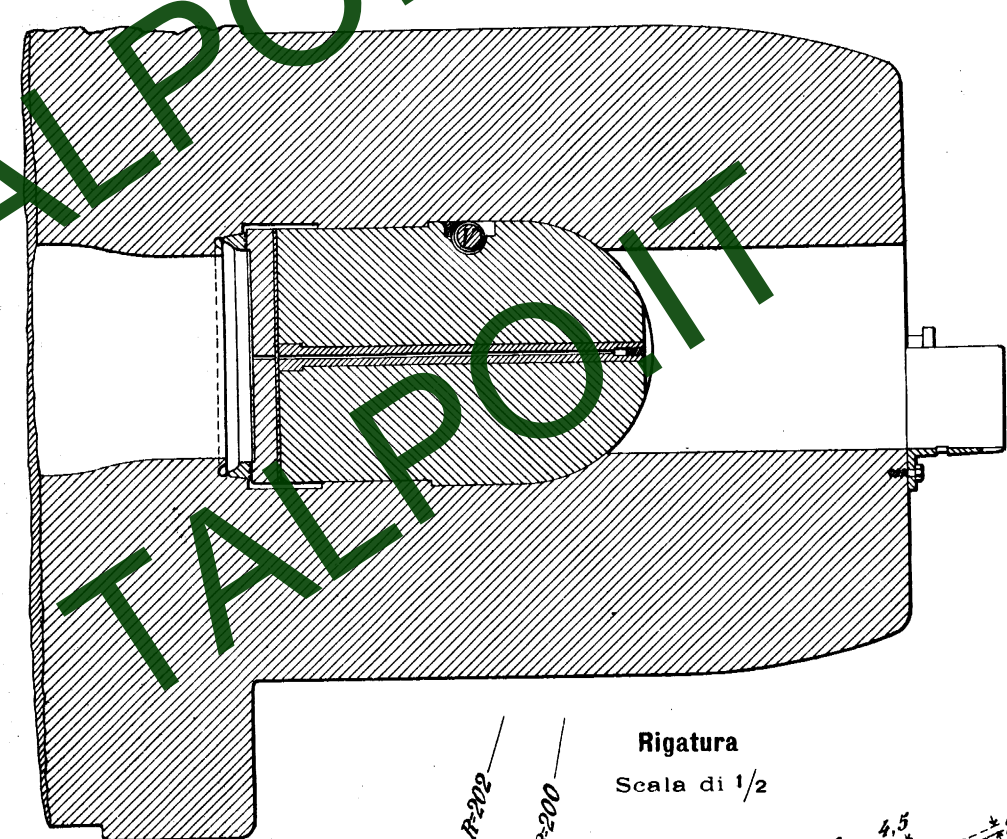

Rigatura  
Scala di 1/2

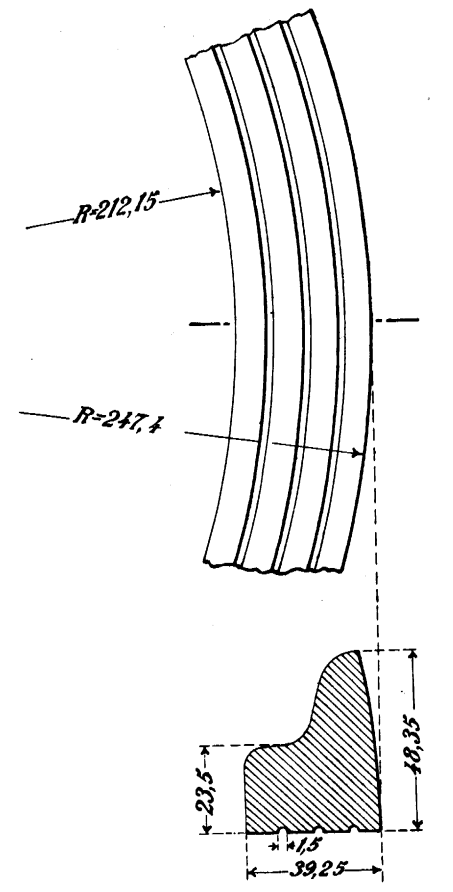
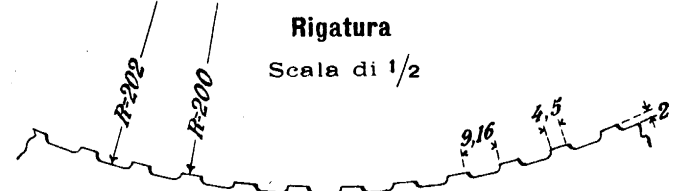

ANTEPRIMA RIDOTTA  
PAGINE MANCANTI  
TALPO.IT



# OBICE DA 280 K

Scala di 1/15

Fianco sinistro

Visto dalla culatta

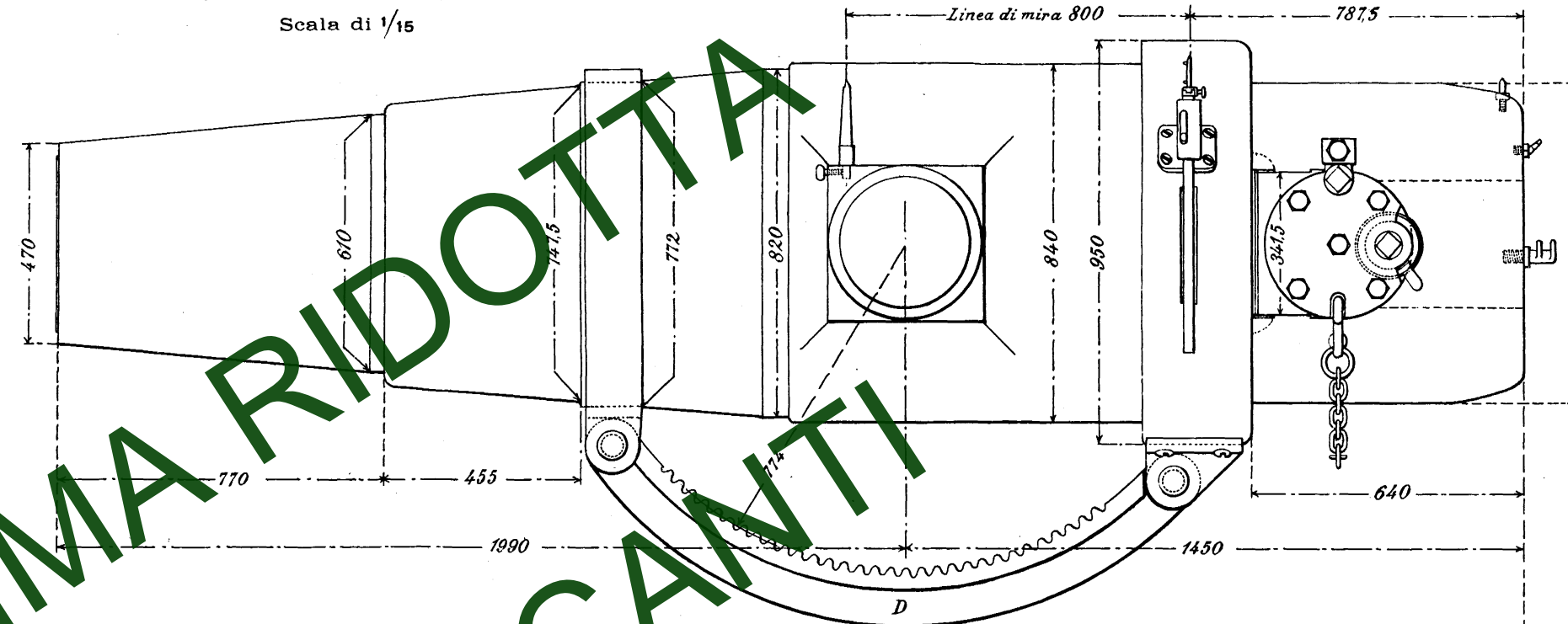
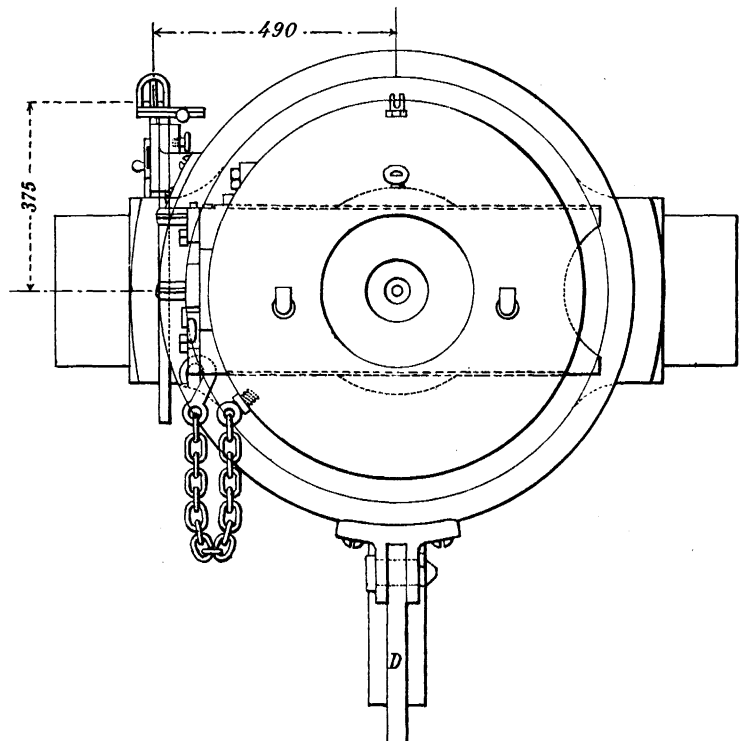

Visto dalla culatta (con otturatore aperto)

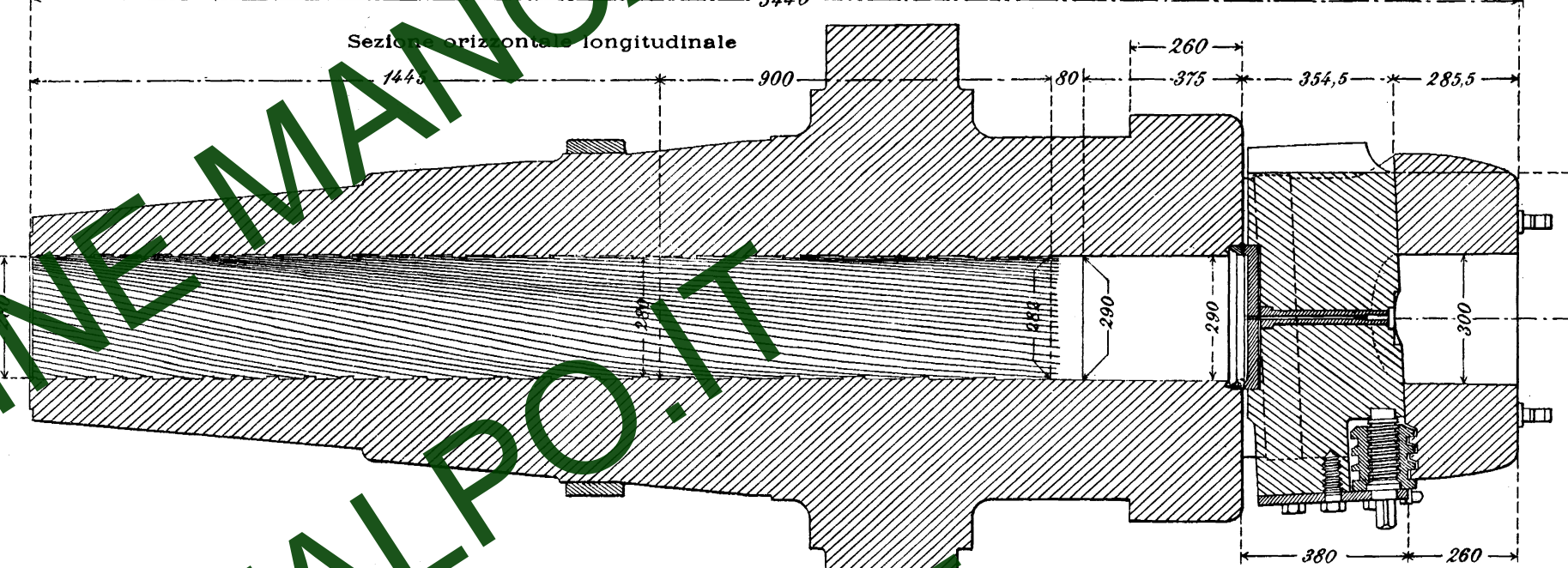
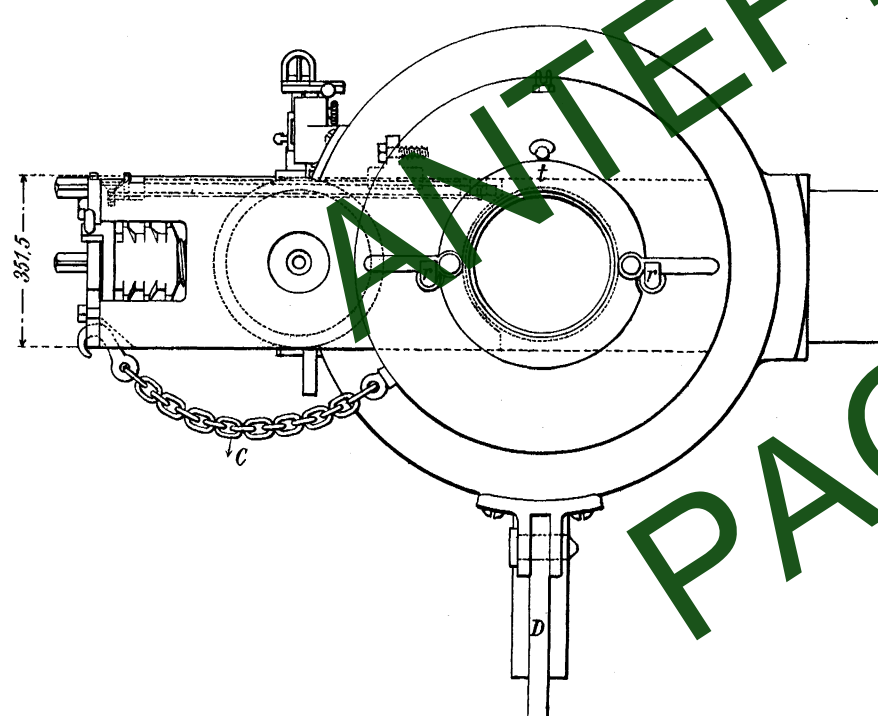

Sezione orizzontale longitudinale

Sezione orizzontale in culatta (con otturatore aperto)

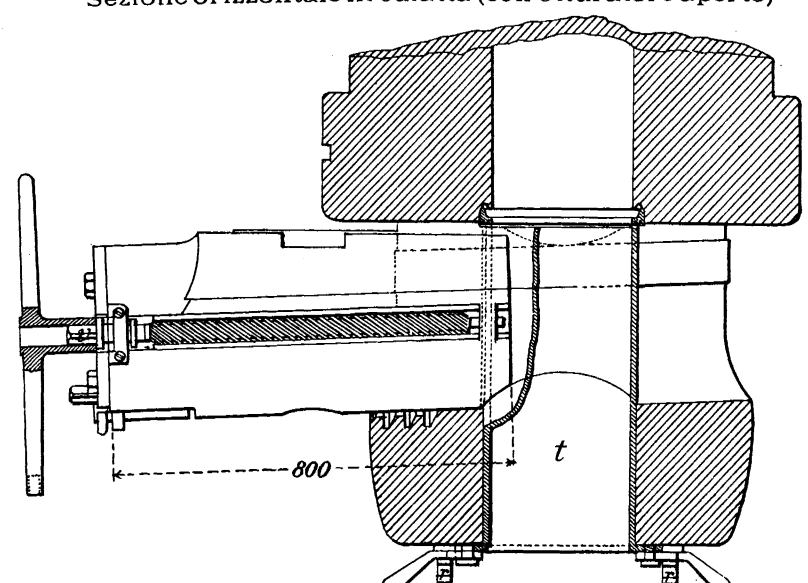

Anello otturatore

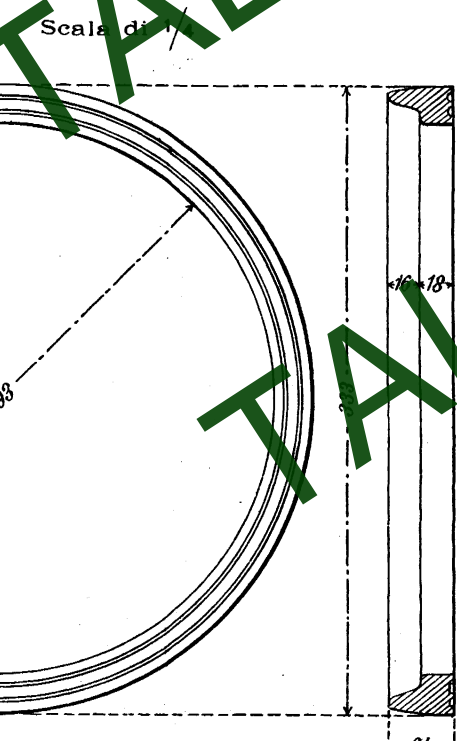

Visto di sopra

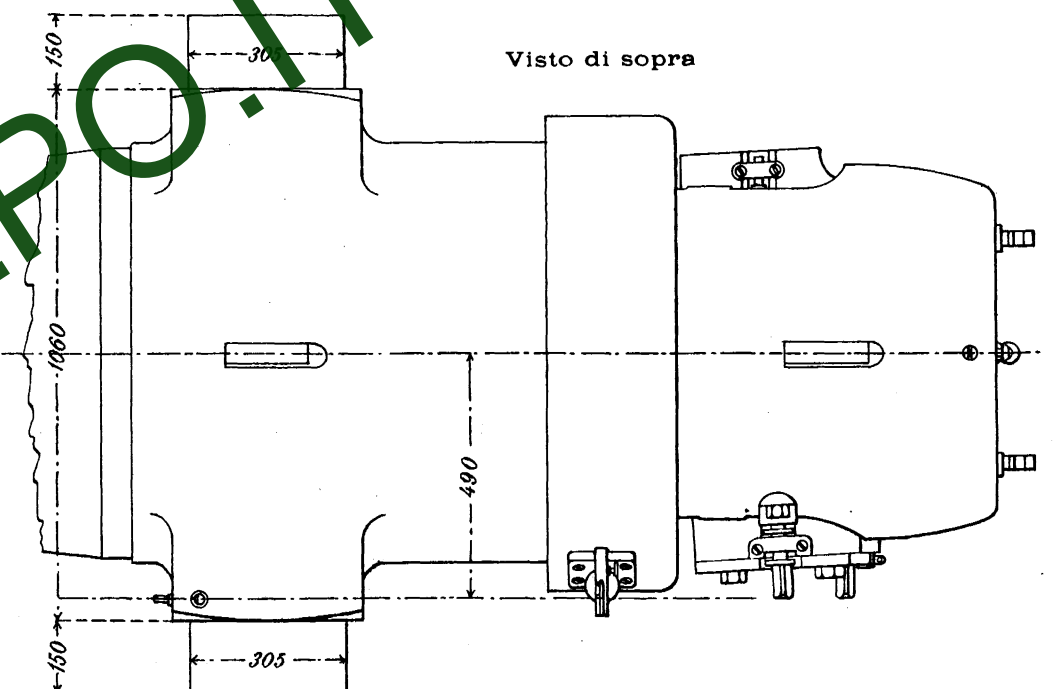

ANTEPRIMA RIDOTTA  
PAGINE MANCANTI  
TALPO.IT



# CANNONE DA 254-B

Vista esterna  
Scala di 1/20

lunghezza totale 8128 = 32 calibri

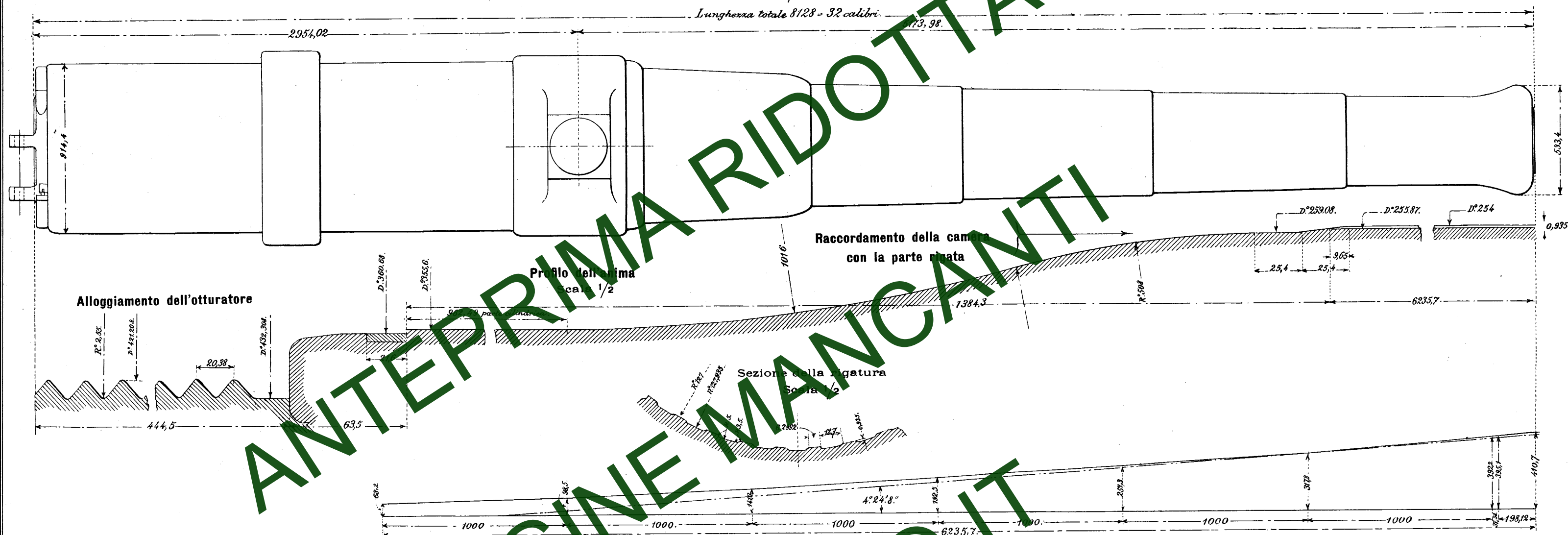

Vista di dietro

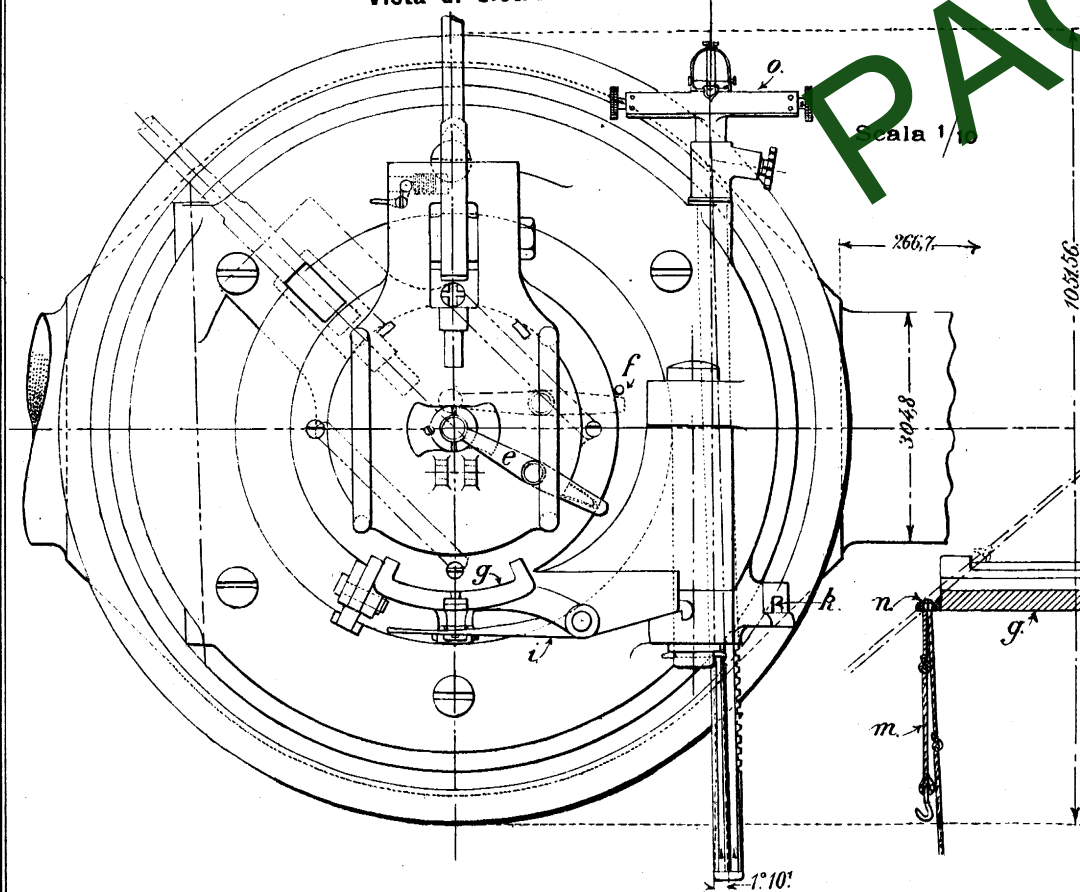

Sezione longitudinale del cannone carico

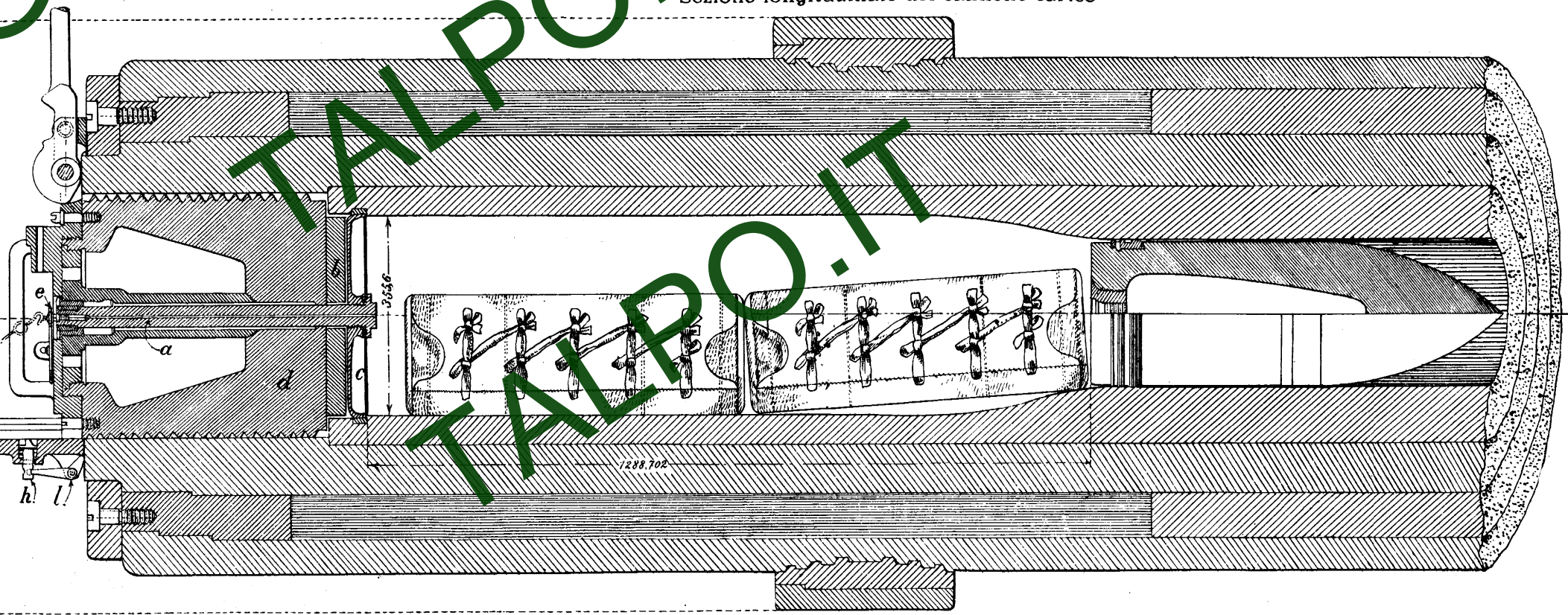

ANTEPRIMA RIDOTTA  
PAGINE MANCANTI  
TALPO.IT



Braccio di destra della suola di mira

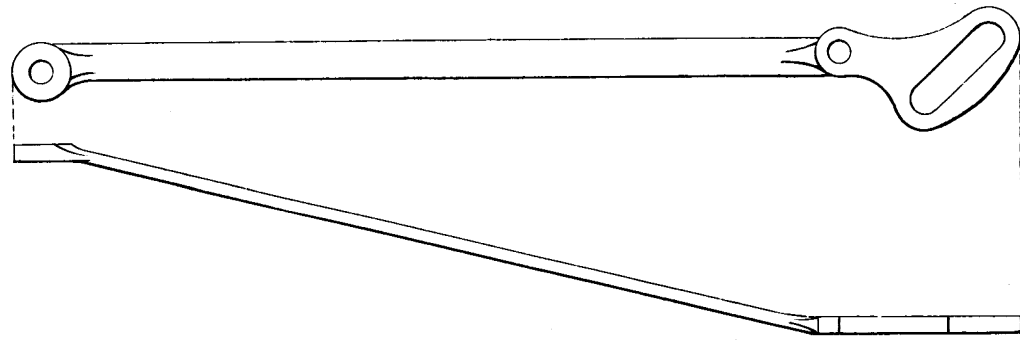

Parti componenti il congegno di punteria

Vite femmina

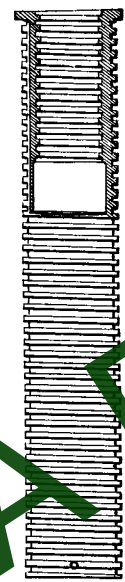

Vite maschia

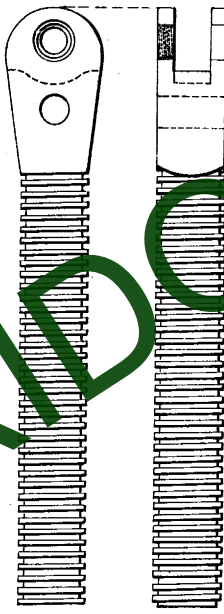

Chiocciola

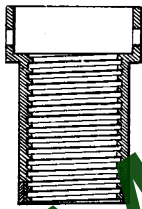

Scala di 1/10

Per i particolari scala di

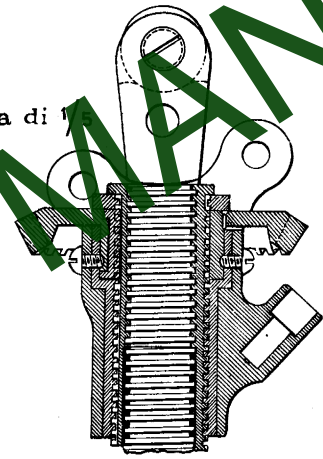

Vista superiore - Coda orizzontale

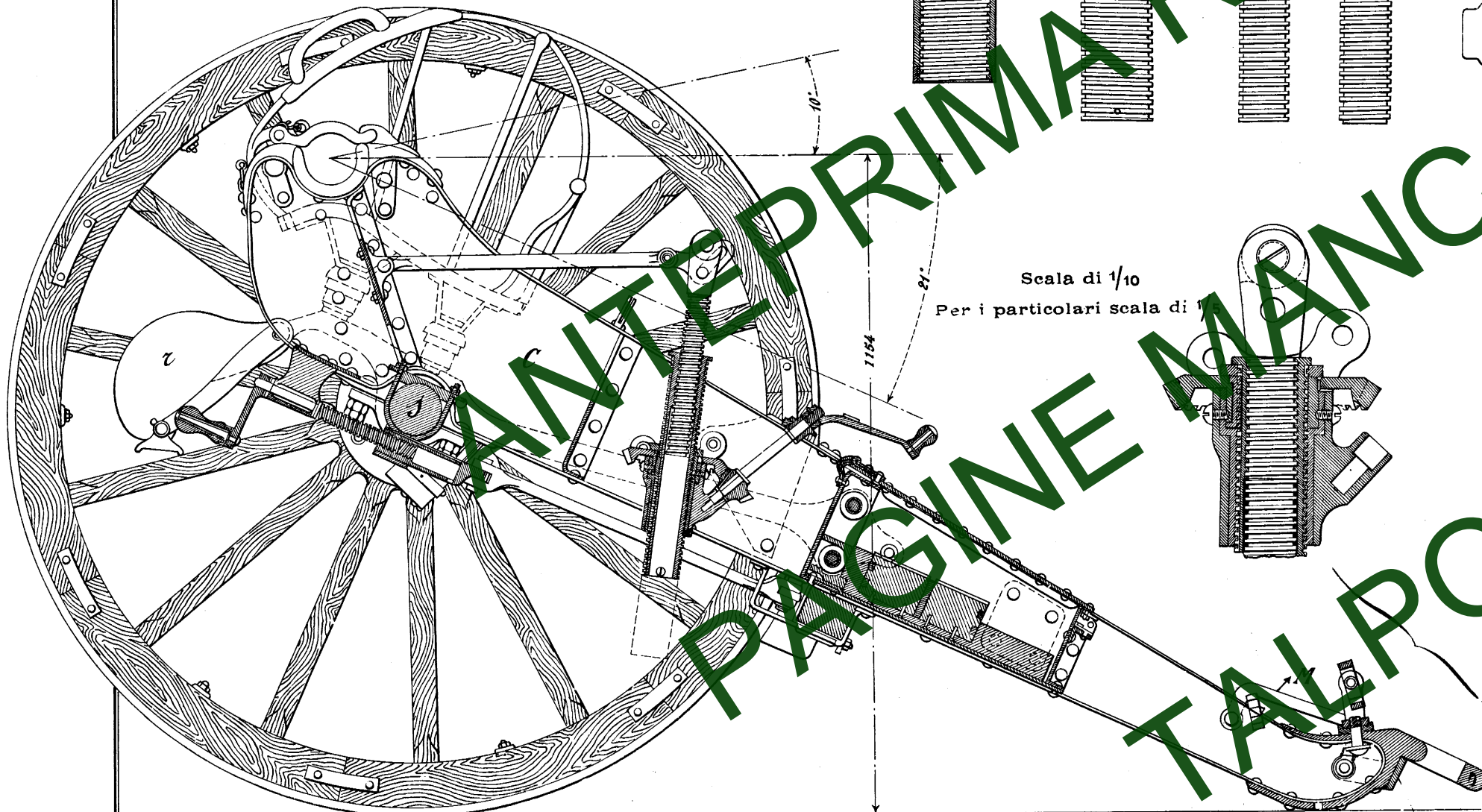
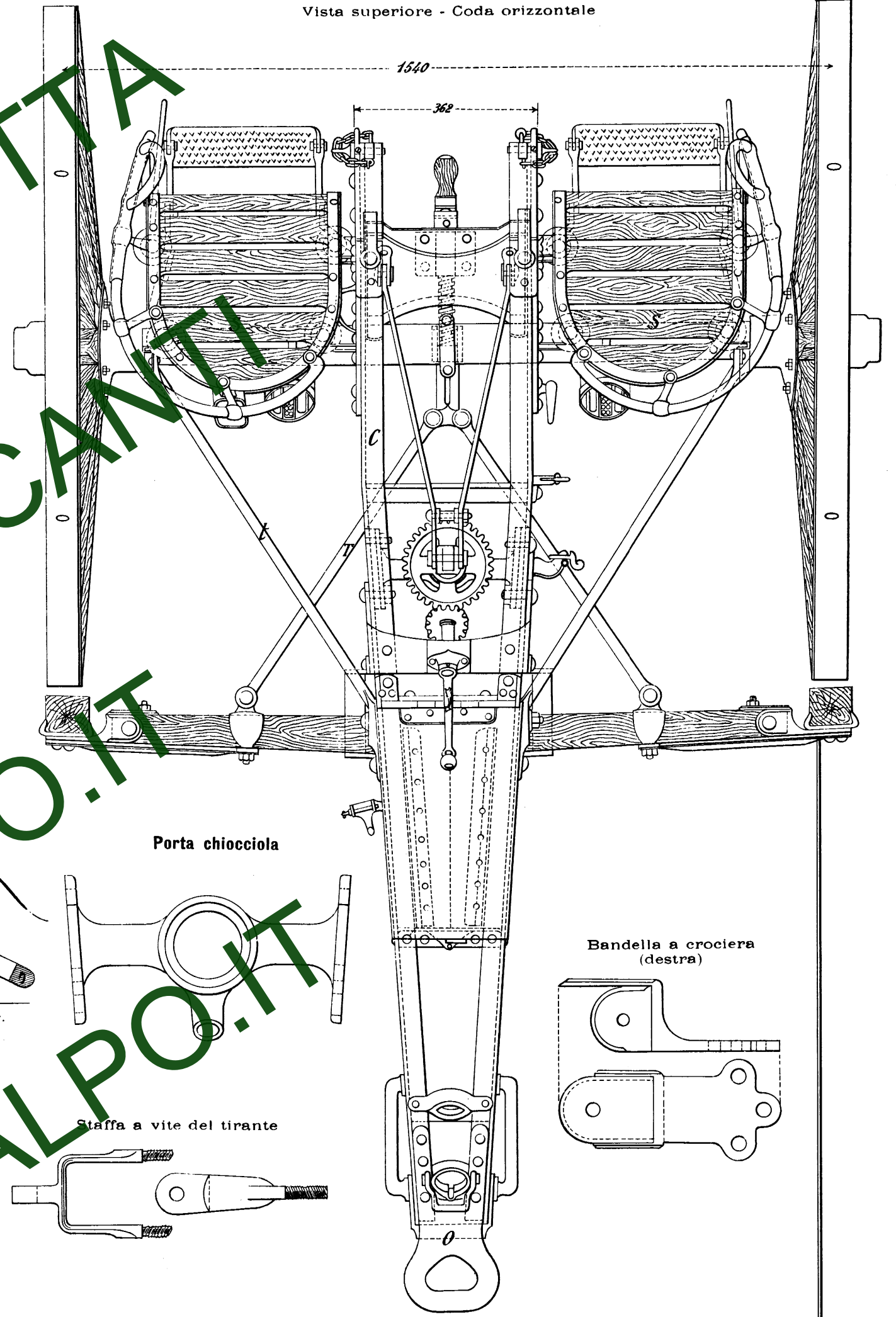

Parti componenti il freno dell'affusto

Vite del freno

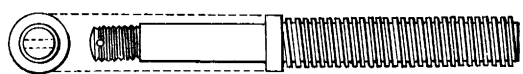

Guida di chiocciola del freno

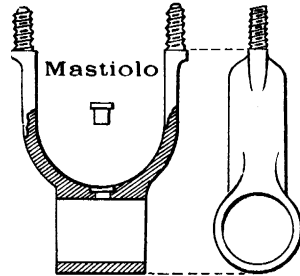

Mensola reggi-vite del freno

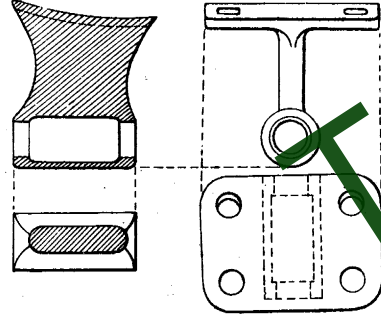

Staffa a vite del tirante

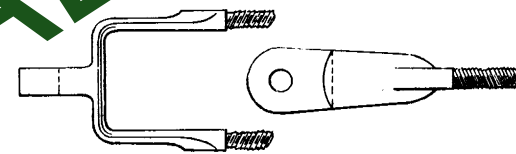

Chiocciola del freno

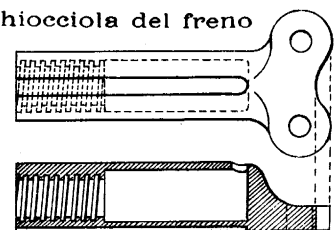

Controstaffa della guida

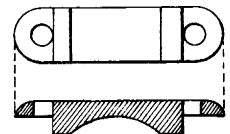

Bandella a crociera (destra)

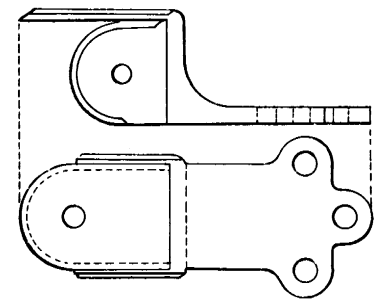



# CANNONE DA 152 C

Sezione longitudinale

Scala di 1/12

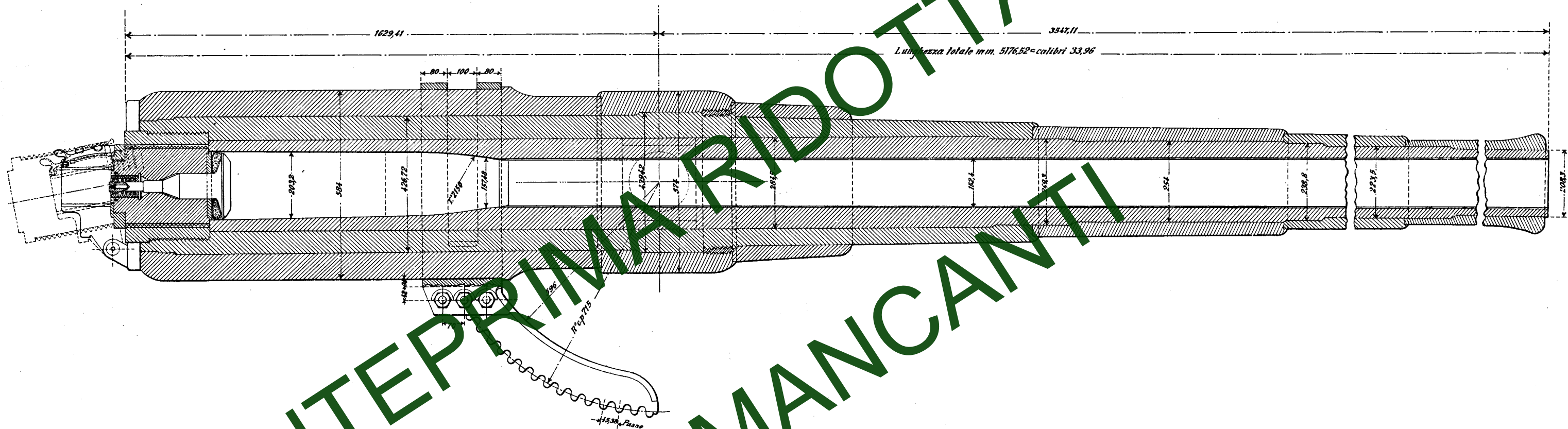

Vista posteriore

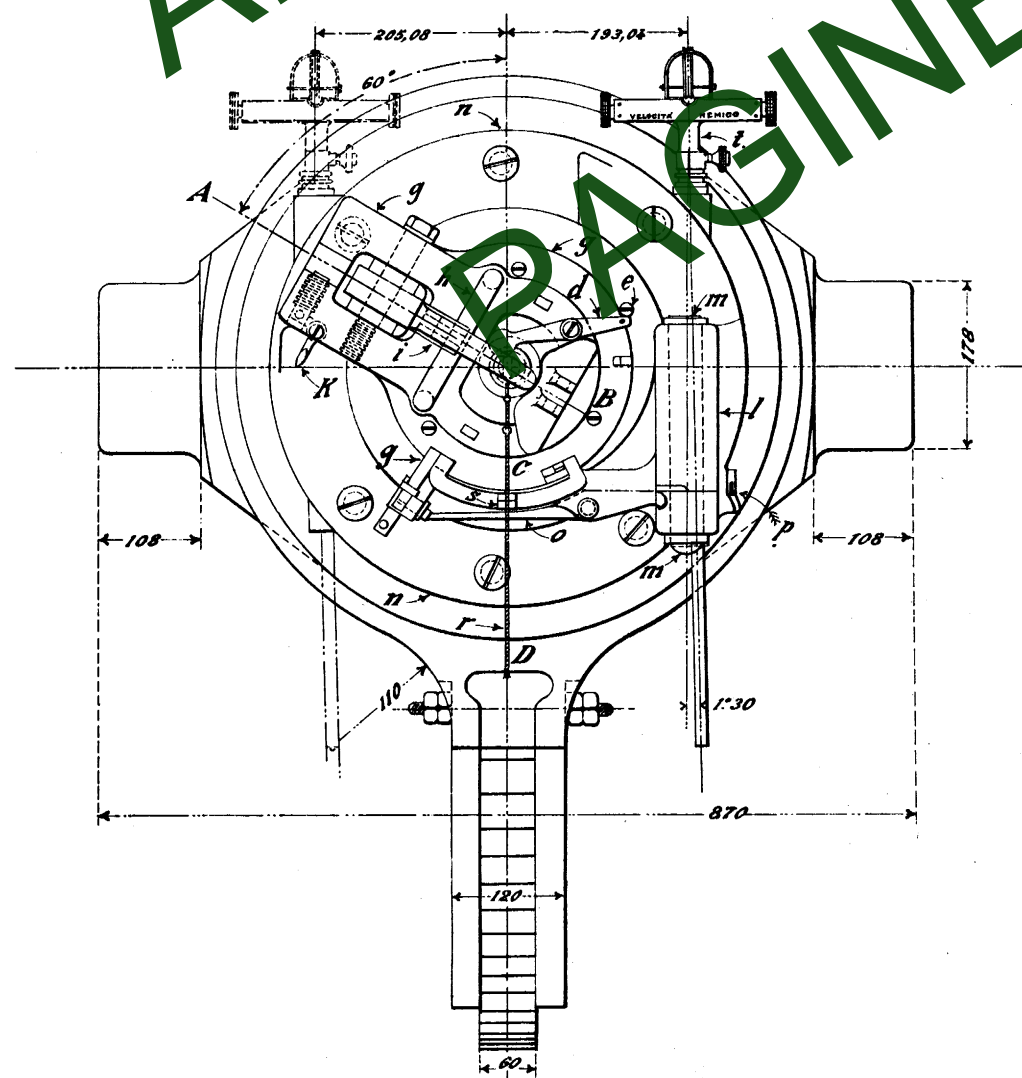

Vista di sopra

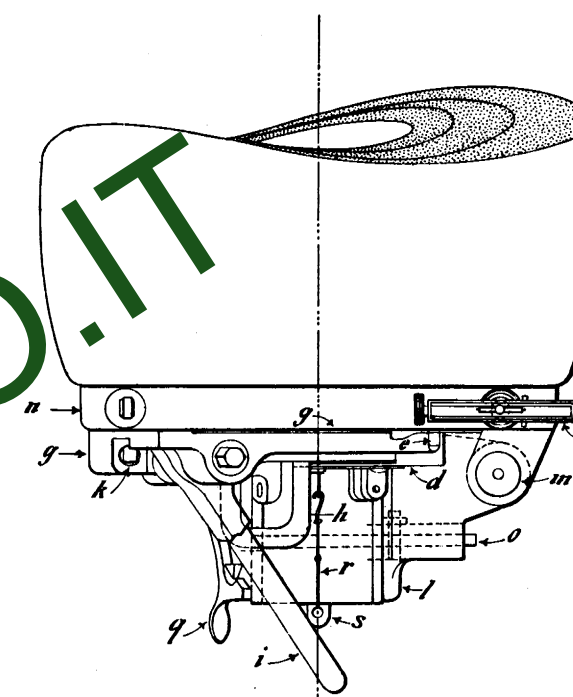

Scala di 1/8

# CANNONE DA 152 (R.M.)

Scala di 1/16

Sezione longitudinale

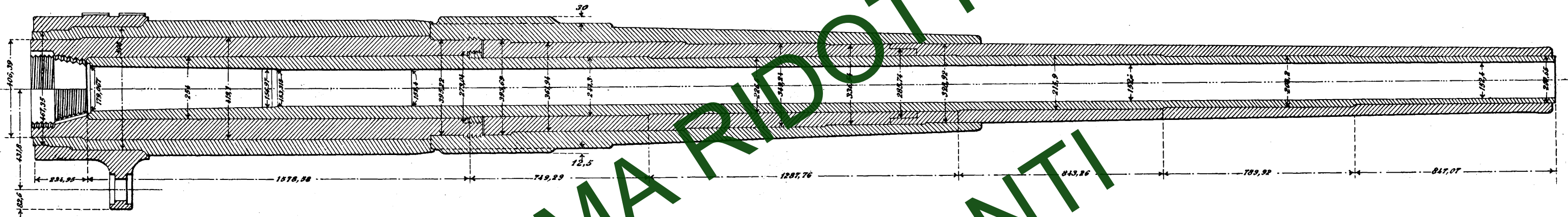

Profilo dell'alloggiamento dell'otturatore, della camera e raccordamento di questa colla parte rigata - Scala 1/2

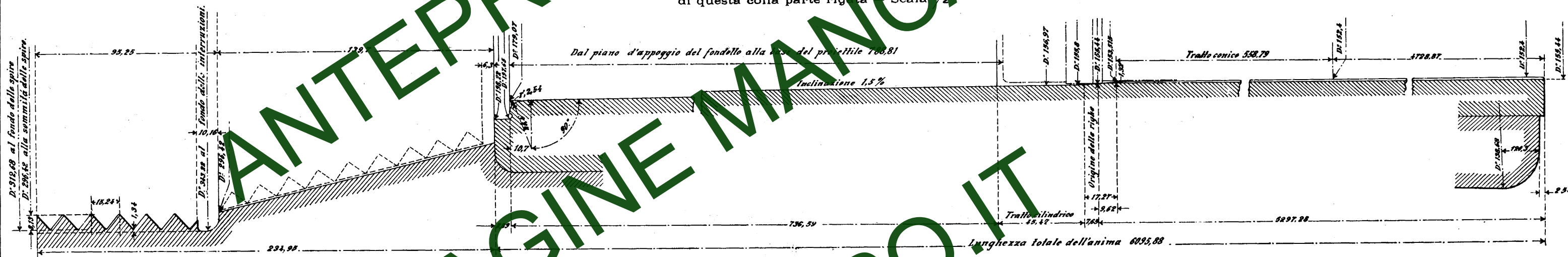

Congegno di otturazione

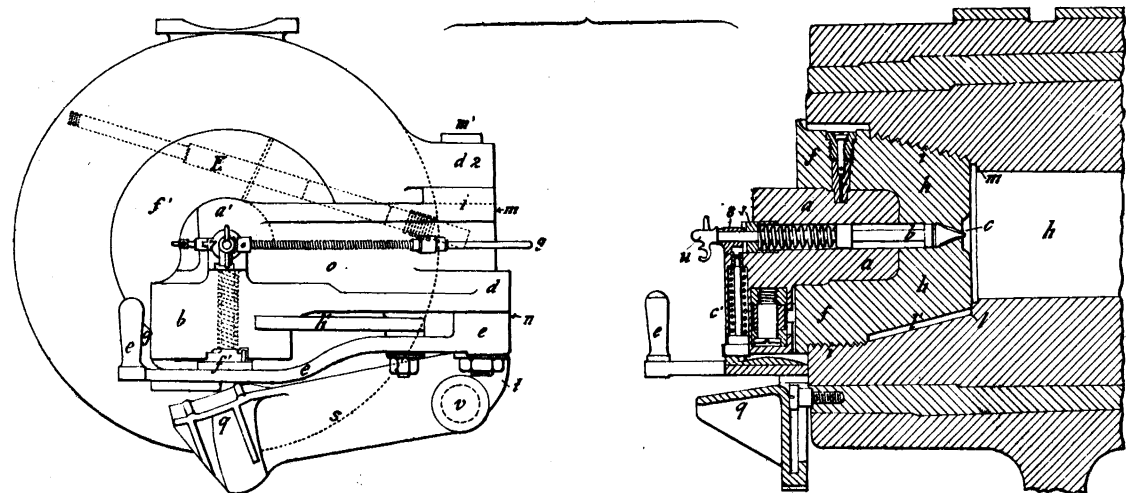

Congegno di percussione

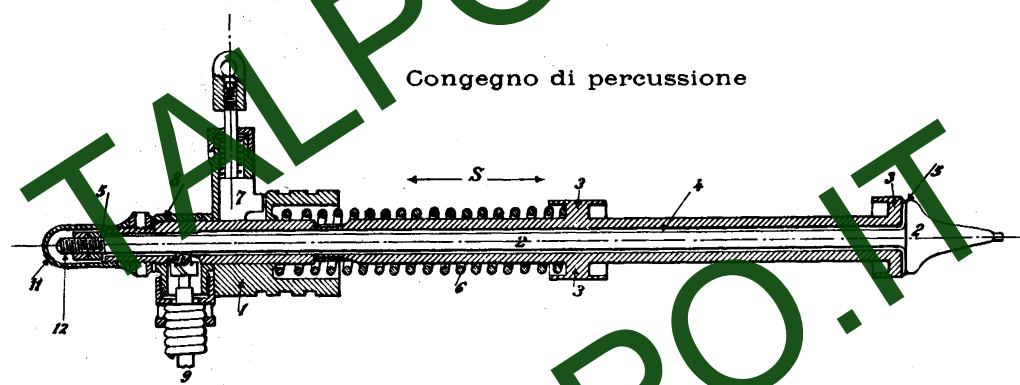

Rappresentazione schematica del funzionamento dell'otturatore - Sezione trasversale della rigatura - Scala 1/1

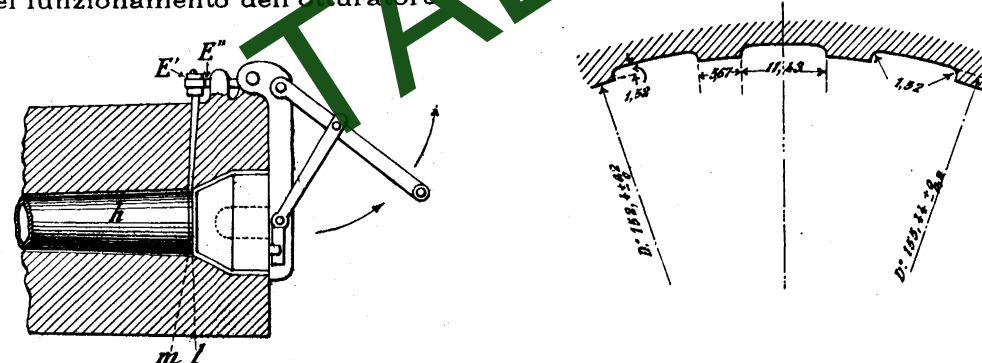

Particolari dei giunti - Scala 1/2

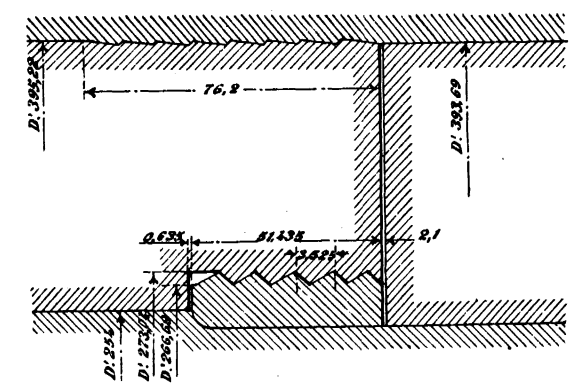



CANNONE da 149 C

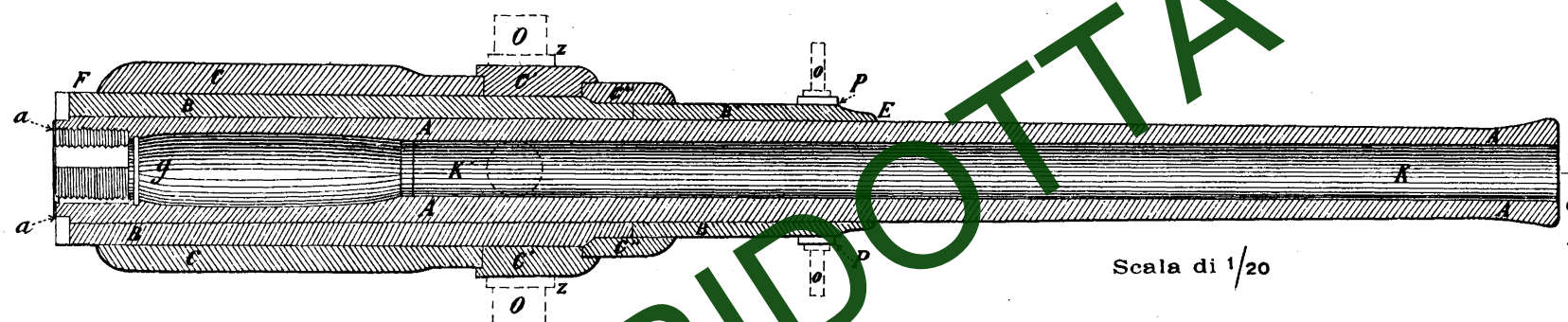

Scala di 1/20

CONGEGNO DI CHIUSURA DEL CANNONE DA 149 C

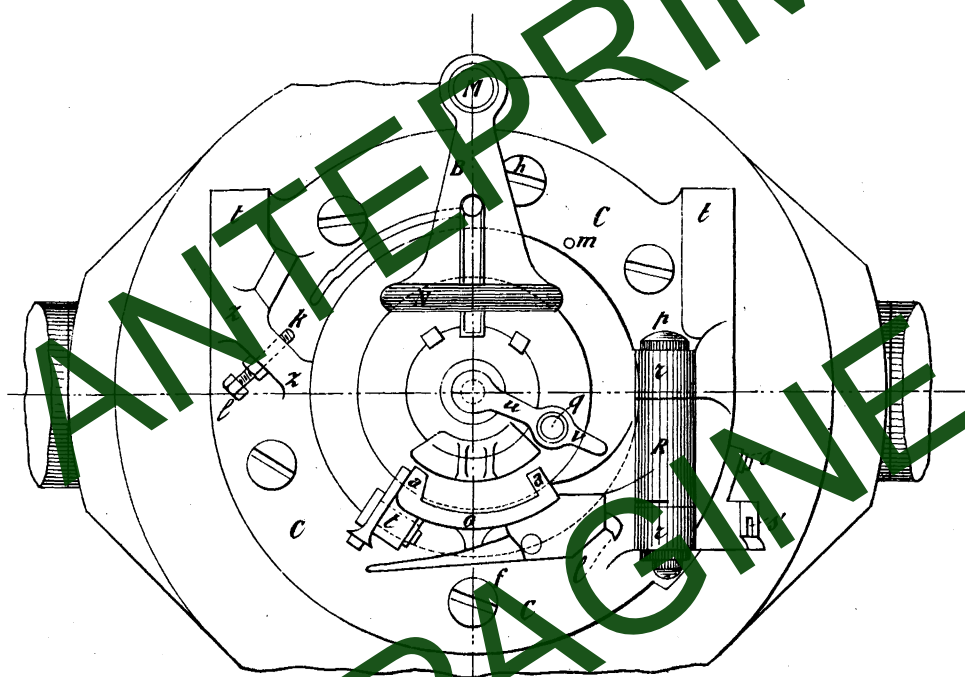

Scala di 1/10

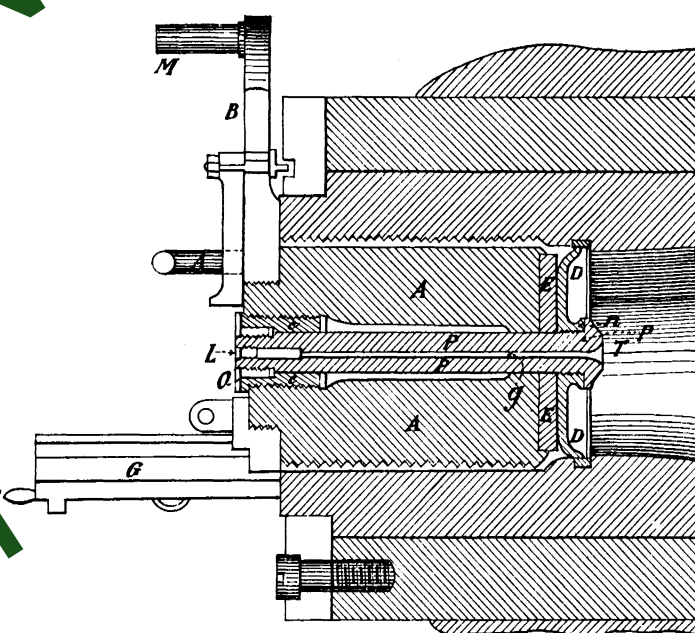

CANNONE da 120 A

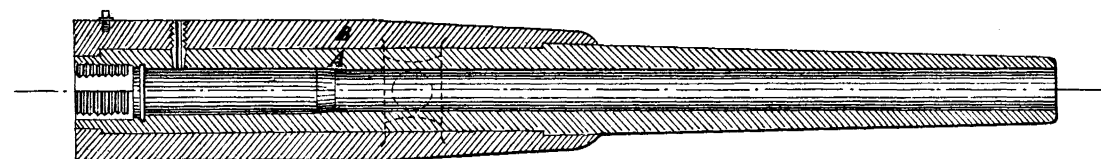

Scala di 1/20

Vista di culatta

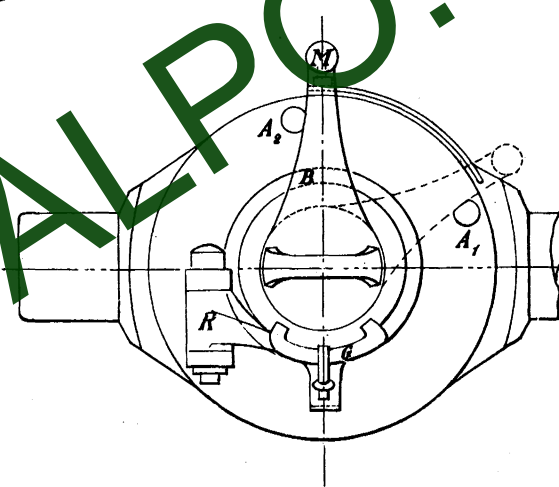

Scala di 1/10

Sezione verticale

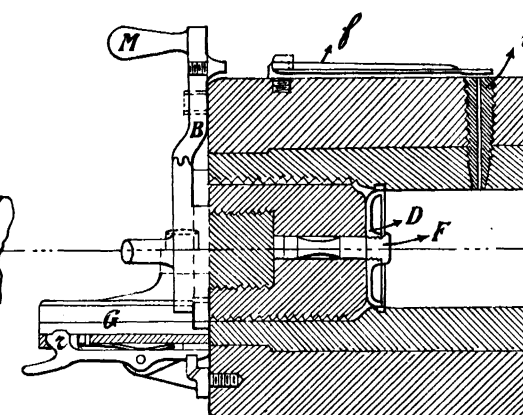

CANNONE da 57 H

Vista esterna con otturatore chiuso

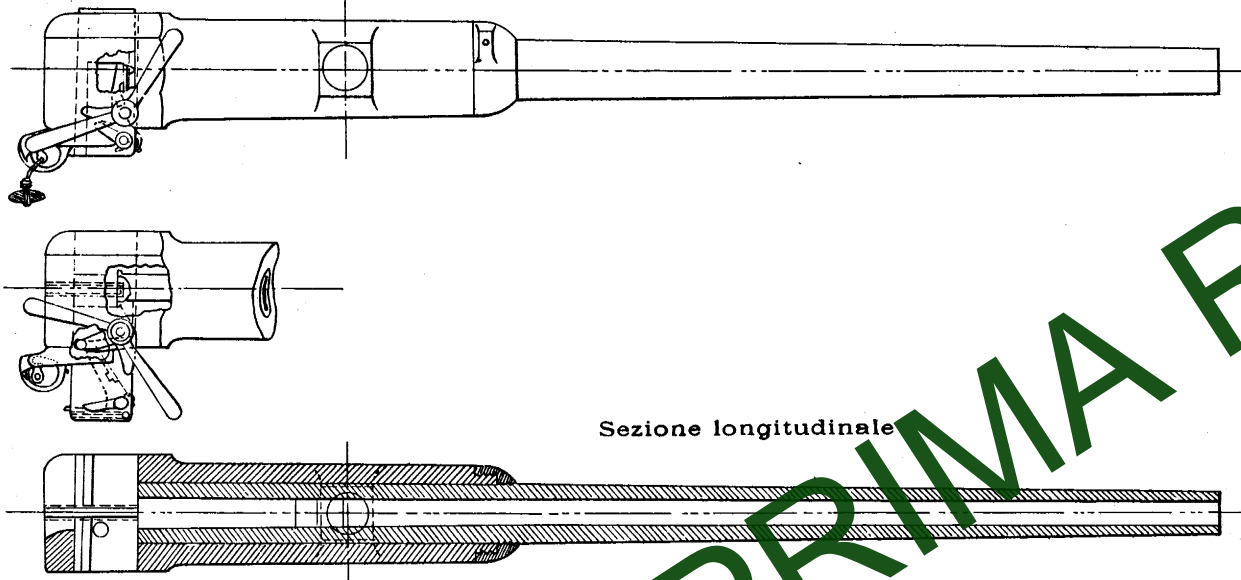

Sezione longitudinale



Scala di 1/16

CANNONE da 57 H

Sezione longitudinale

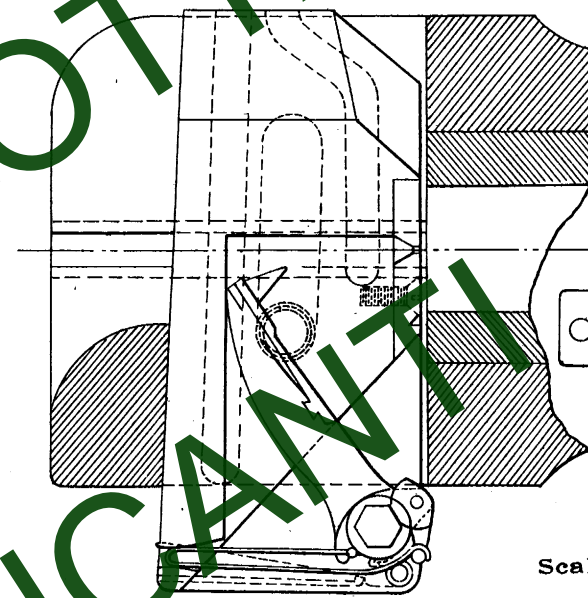

Scala 1/4

Congegno di culatta

Sezione trasversale

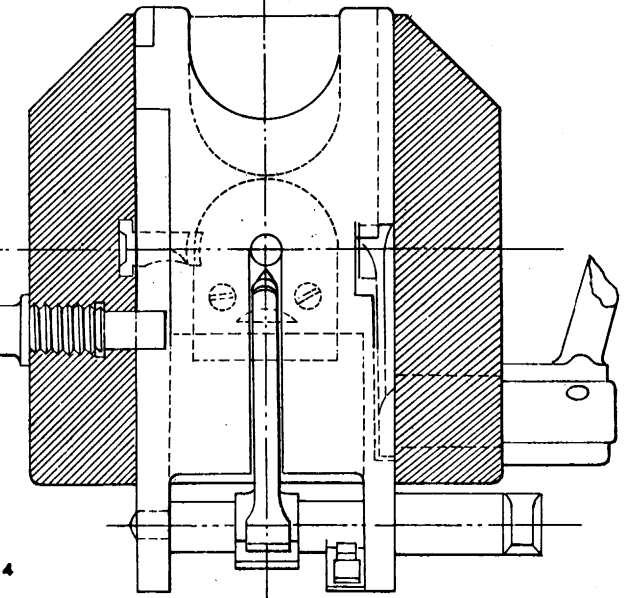

CANNONE da 37 H

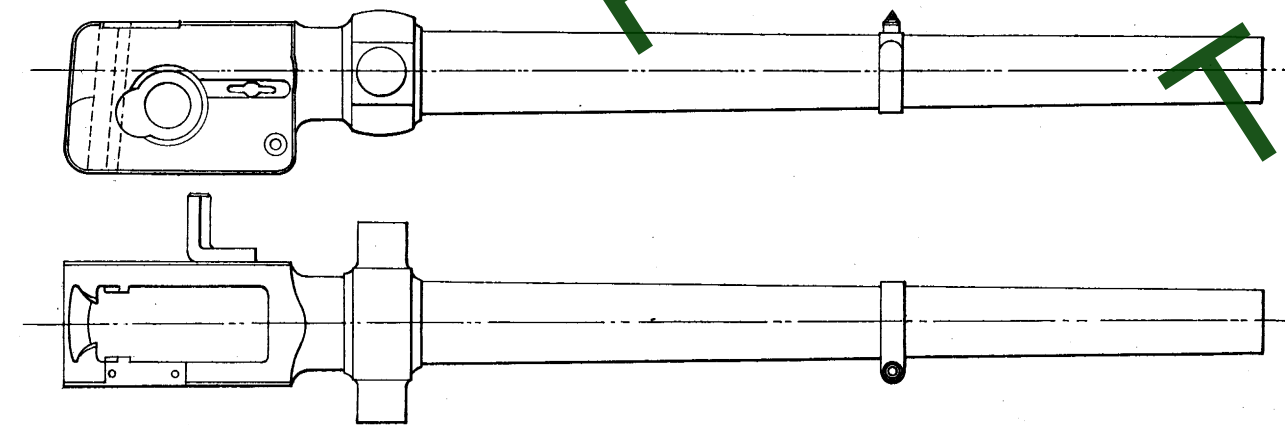

Scala di 1/7

CANNONE da 37 H - Vista di fianco

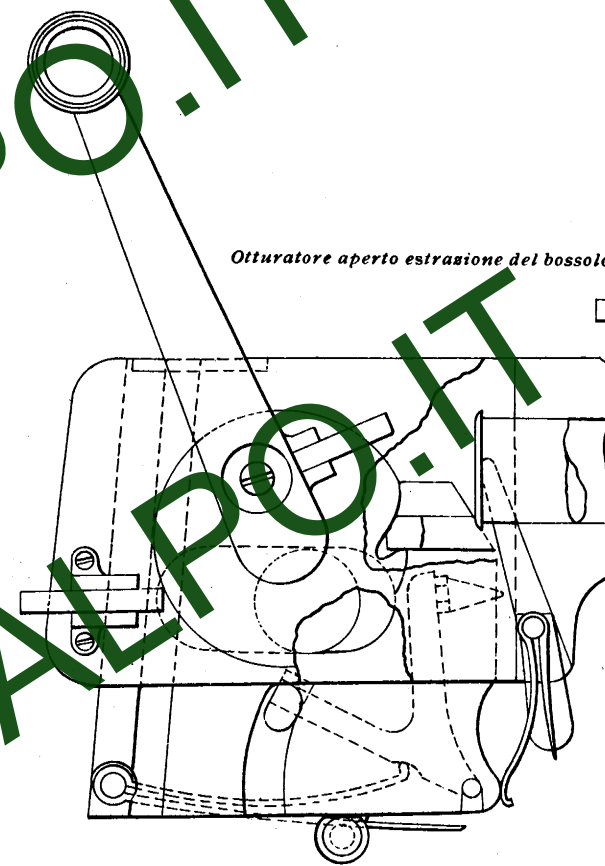

Otturatore chiuso pronto allo sparo

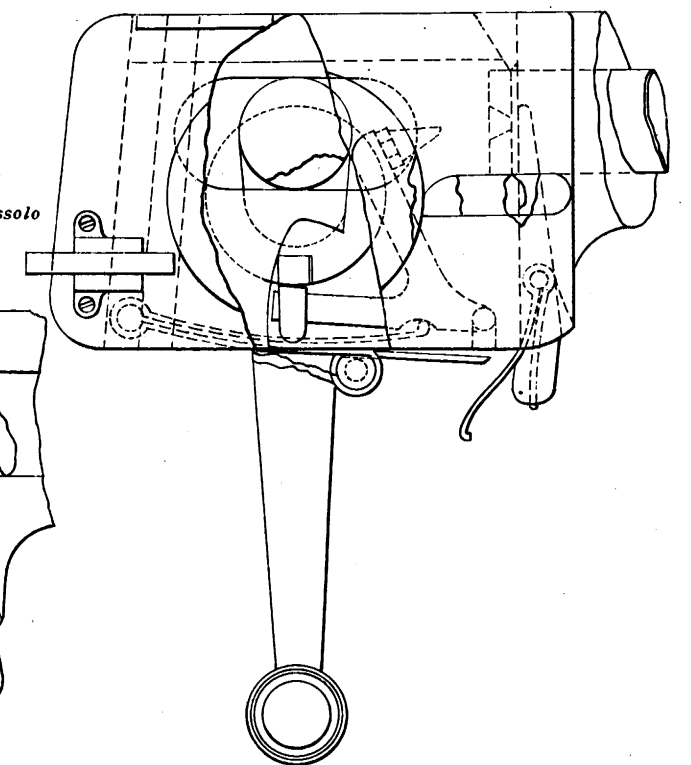

Otturatore aperto estrazione del bossolo

Scala 1/3

ANTEPRIMA RIDOTTA  
PAGINE MANCANTI  
TALPO.IT



# CANNONE DA 152 B

Sezione longitudinale

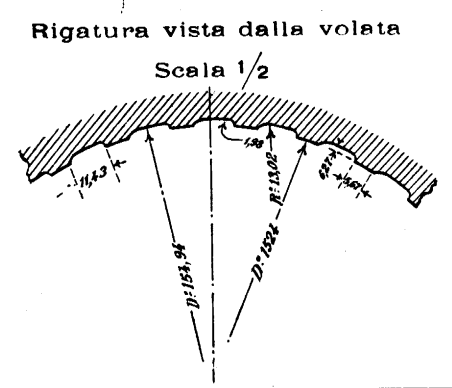
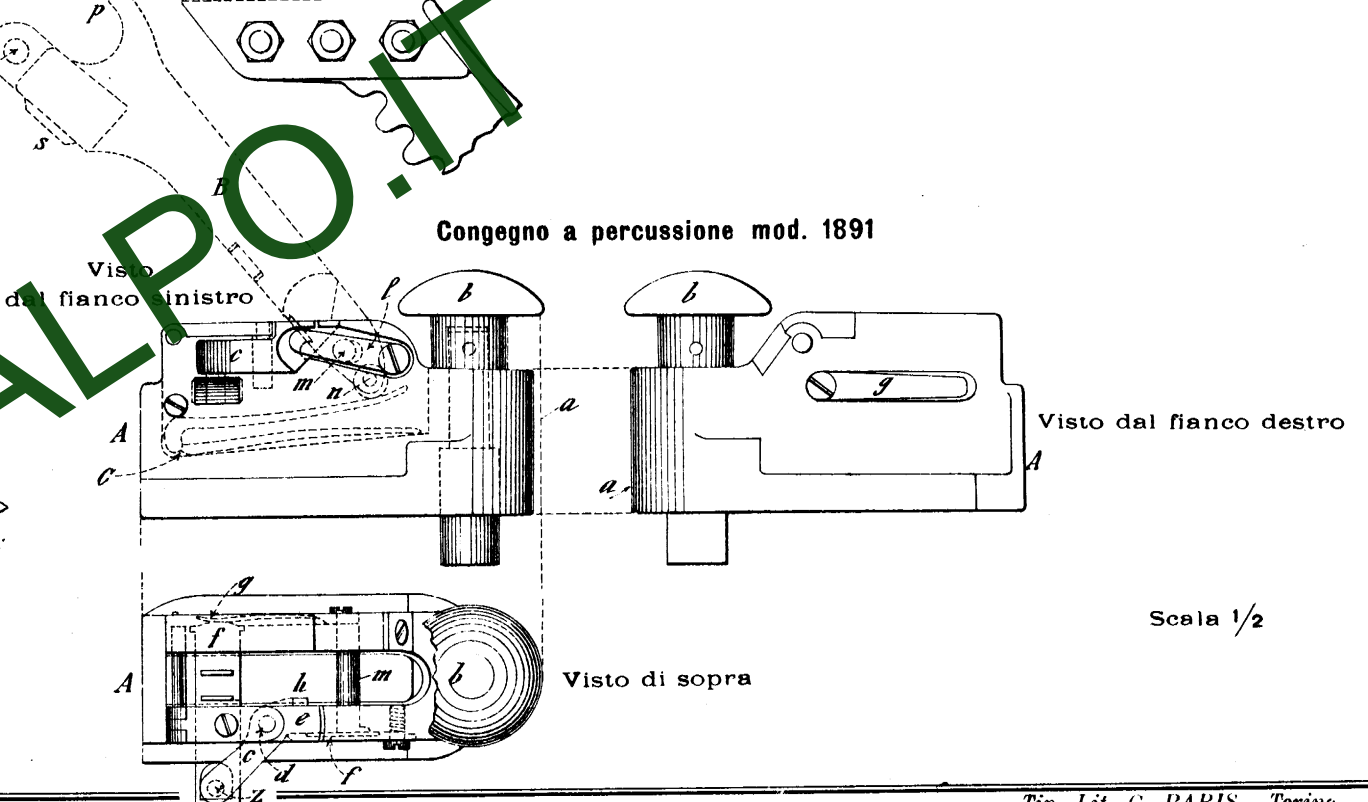
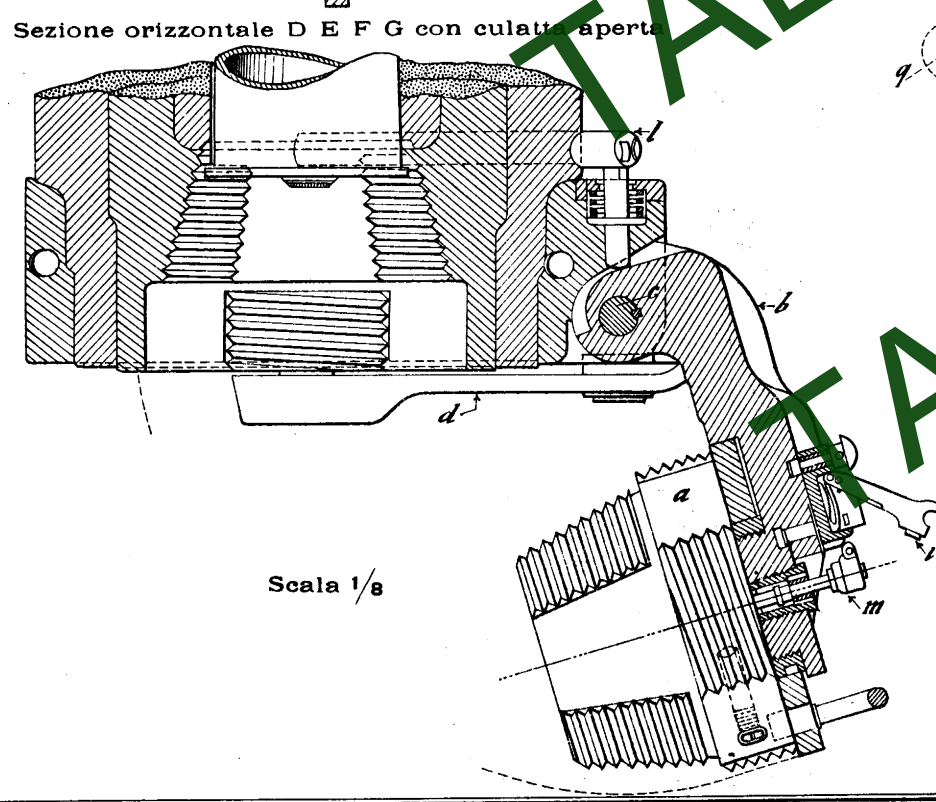
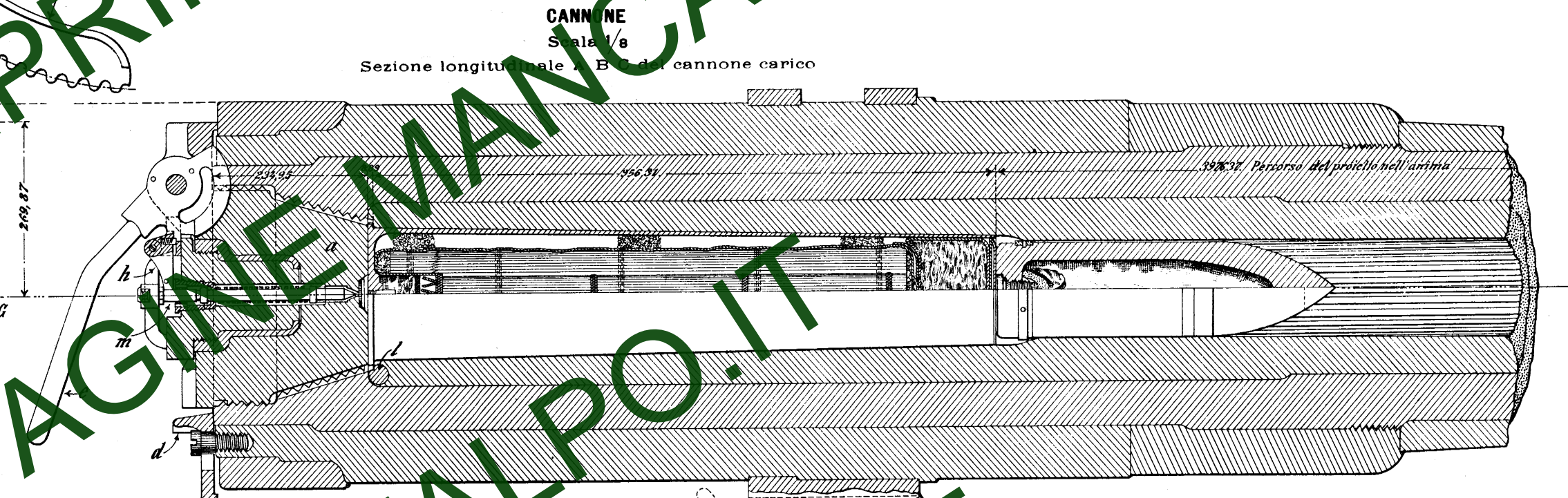
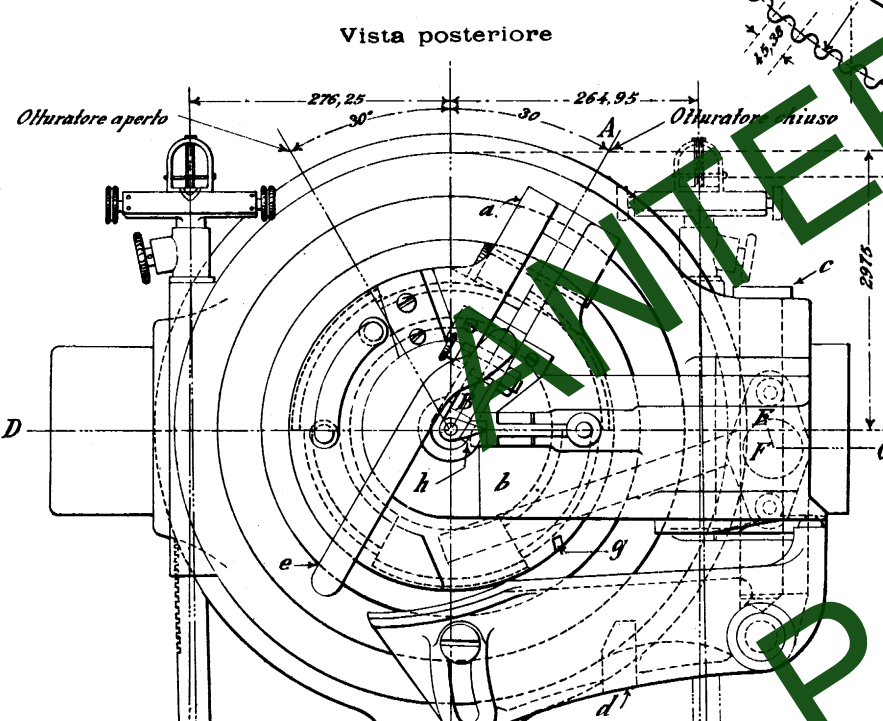
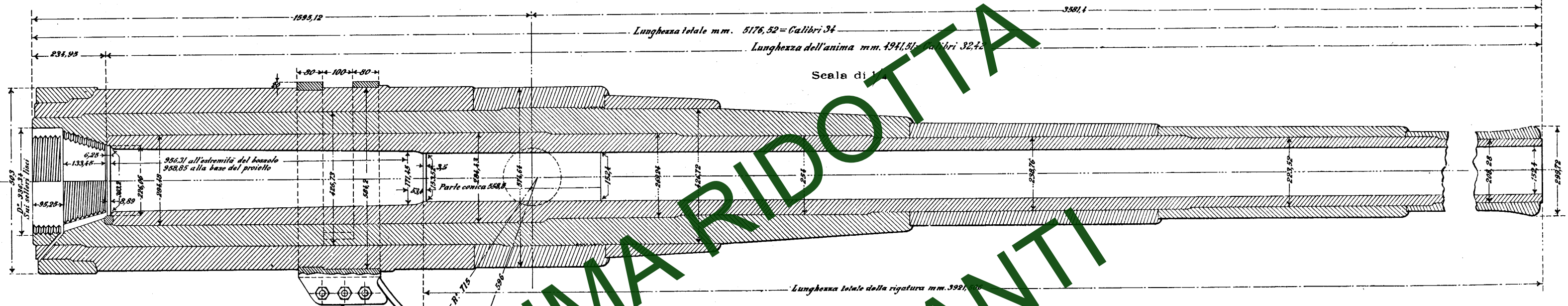



AFFUSTO DA CAMPAGNA MOD. 98 DA 87 B/98  
CON PIASTRA ALLARGATA DI CODA

AFFUSTO DA CAMPAGNA MOD. 98 DA 87 B/98  
CON OCCHIONE A PIASTRA ALLARGATA

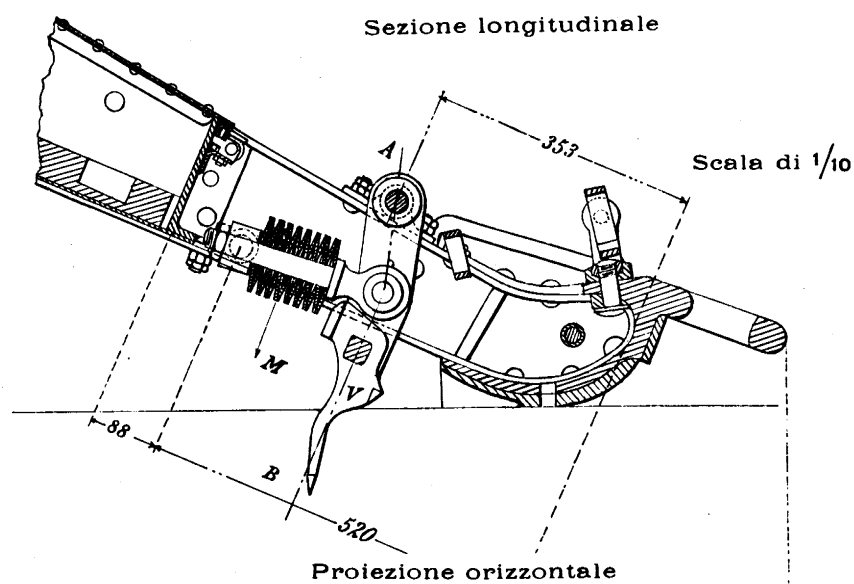

Sezione longitudinale

Scala di 1/10

(Sezione A B)

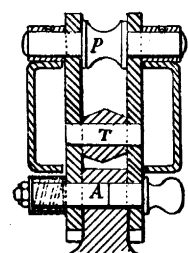

Piastra allargata di coda

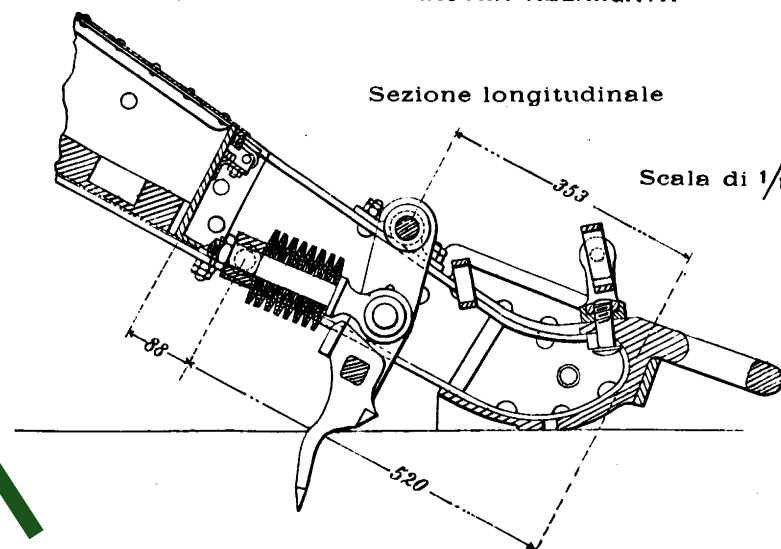
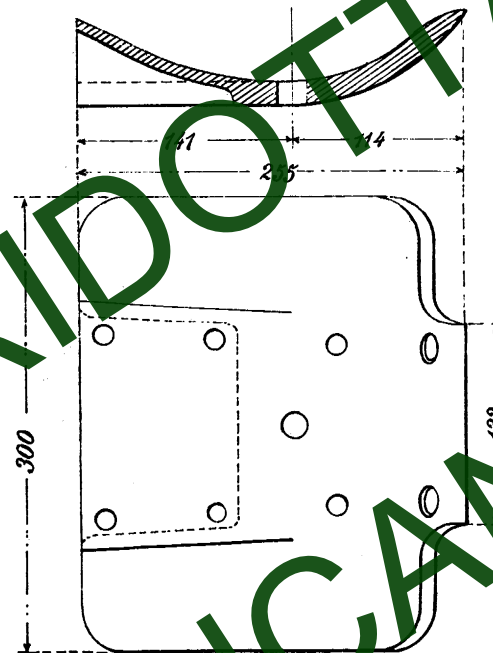

Sezione longitudinale

Scala di 1/10

Occhione a piastra allargata

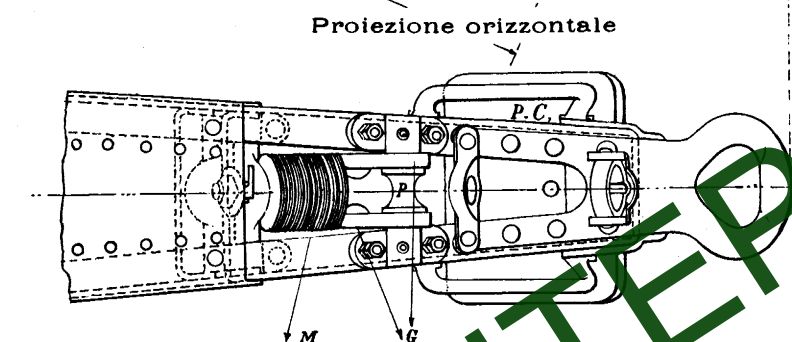
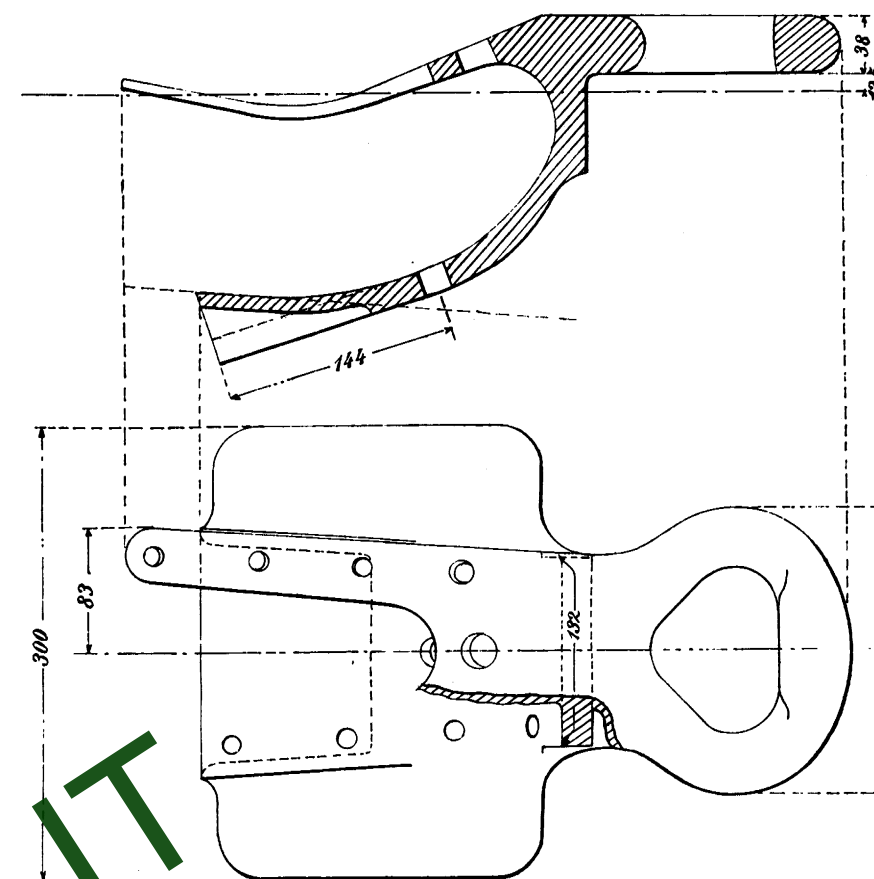

Proiezione orizzontale

Guance



di destra

di sinistra

Piastra a vomero

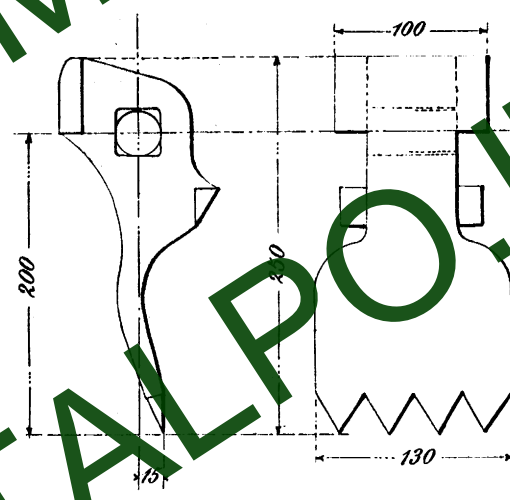

Ralla superiore di destra

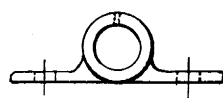

Chiavarda delle ralle



Ralla inferiore di destra



Sotto orecchioni ad alie di sinistra

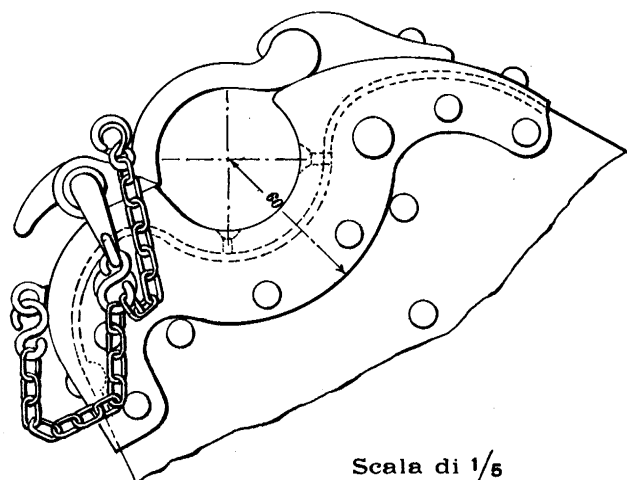

Scala di 1/5

Traversa

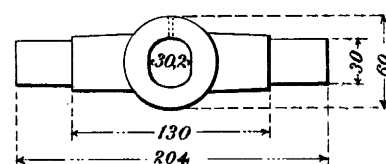

Perno

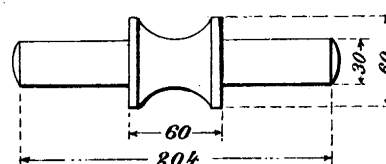

Tirante con dado e copiglia

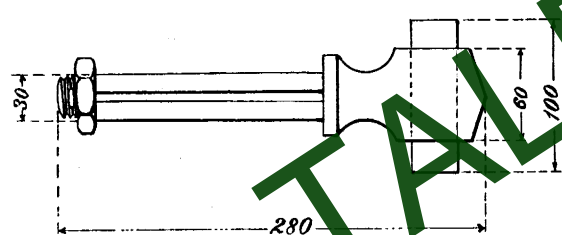

Asticolo con rosetta, dado e copiglia

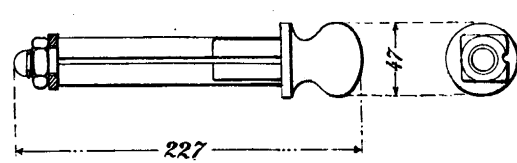

Molla a calotta

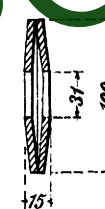

Astuccio e molla spirale

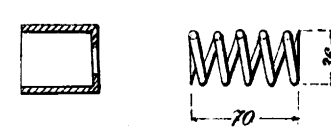

Piastra a vomero

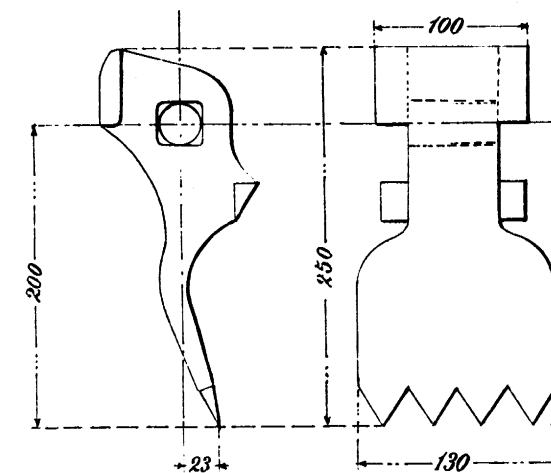

ANTEPRIMA RIDOTTA  
PAGINE MANCANTI  
TALPO.IT

Ritegno a snodo di ruota di ricambio



Figura d'insieme

RETROTRENO PER MUNIZIONI DA 87 B

AVANTRENO PER MUNIZIONI DA 87 B  
Proiezione orizzontale

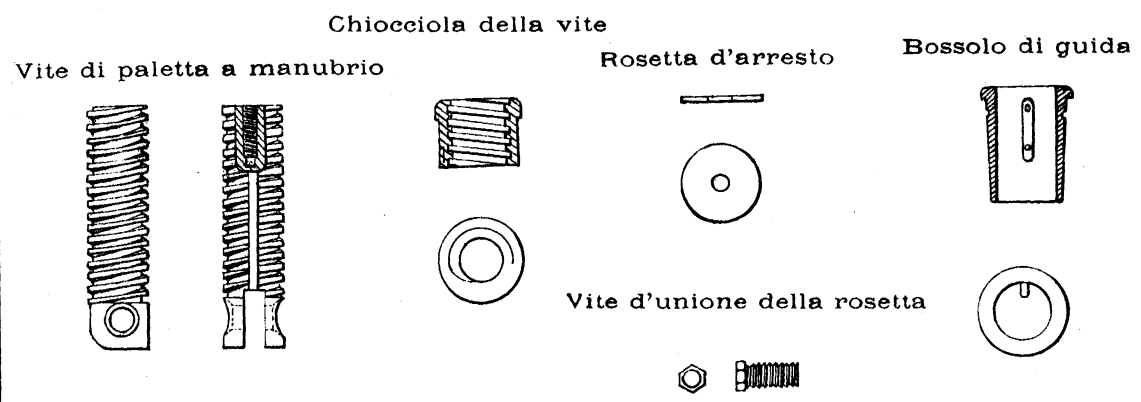
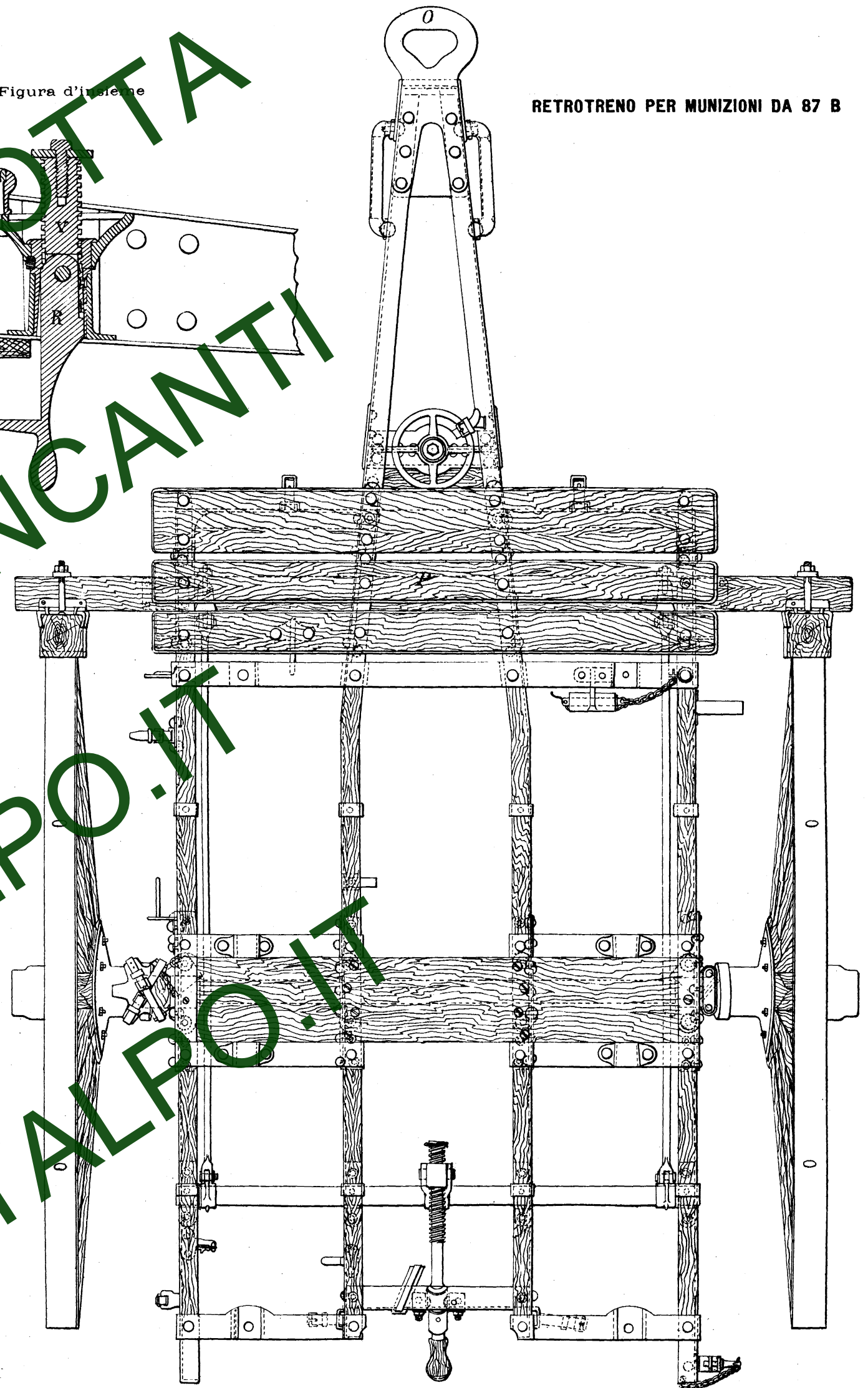
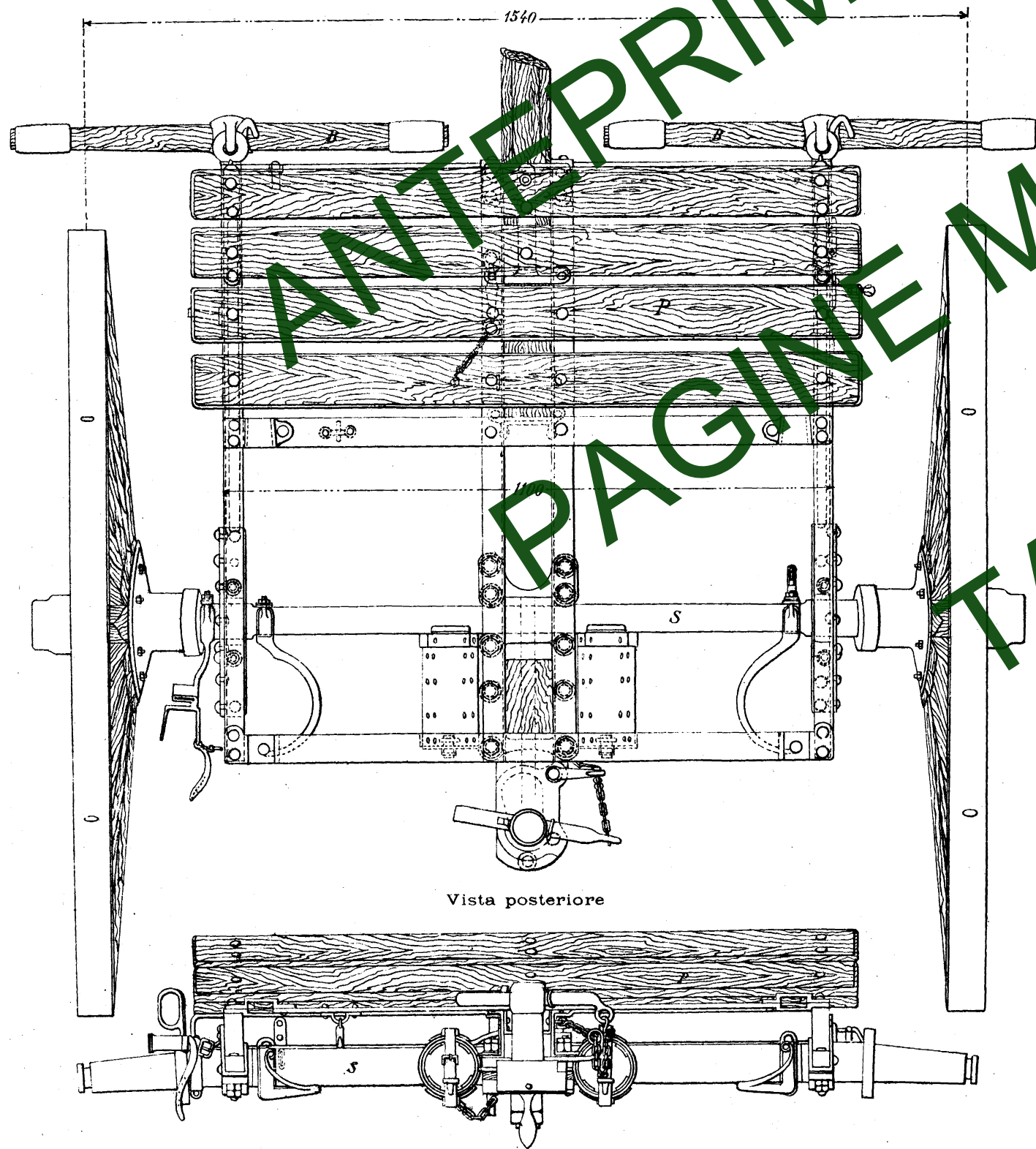

Scala di 1/10



AVANTRENO PER MUNIZIONI DA 87 B  
Scala di 1/10

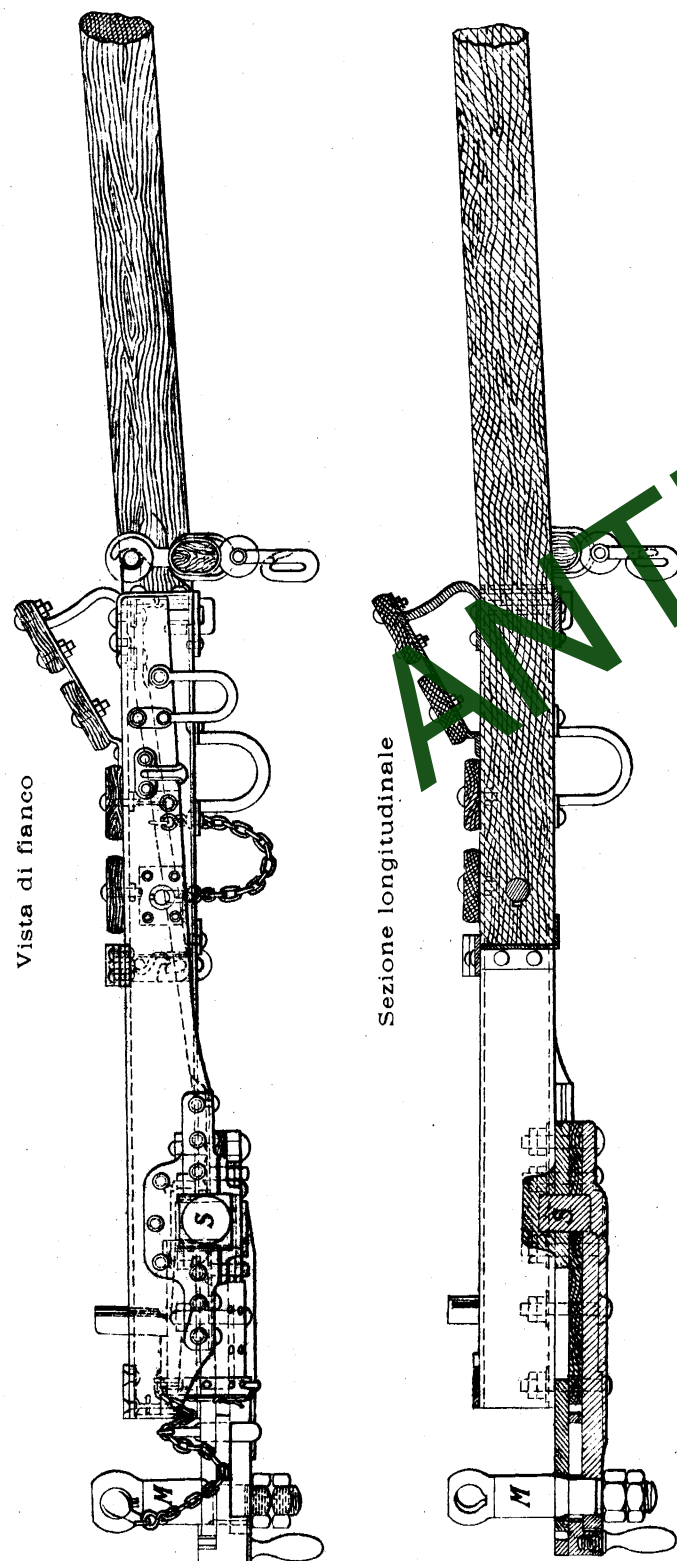

RETROTRENO PER  
MUNIZIONI DA 87 B

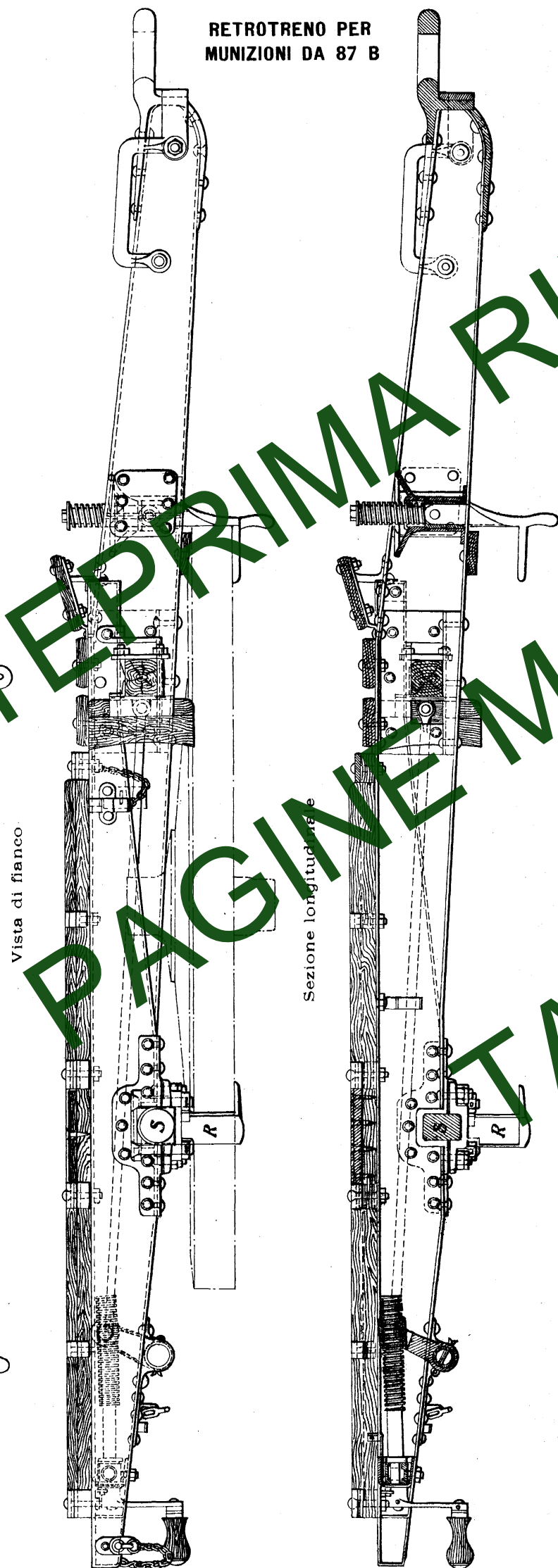

Unione dei due treni da 87 B  
Scala 1/5

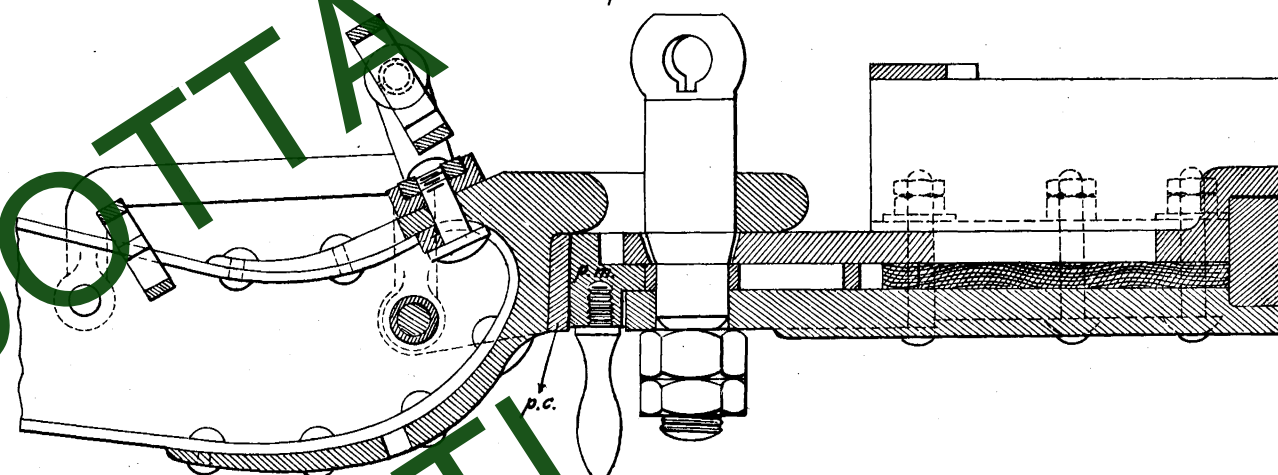

Maschio

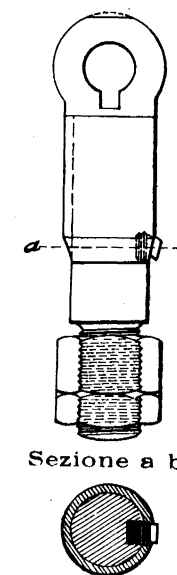

Chiavistello di maschio

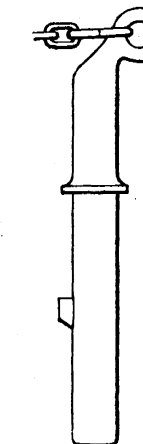

Piastre mobile

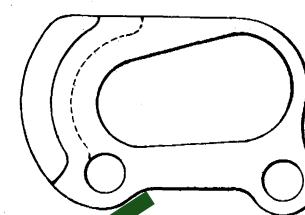

Piastrone superiore di reggi maschio

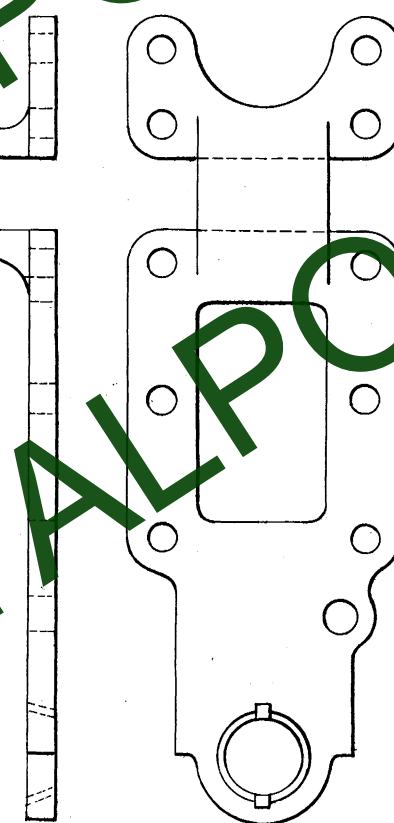

Piastrone inferiore di reggi maschio

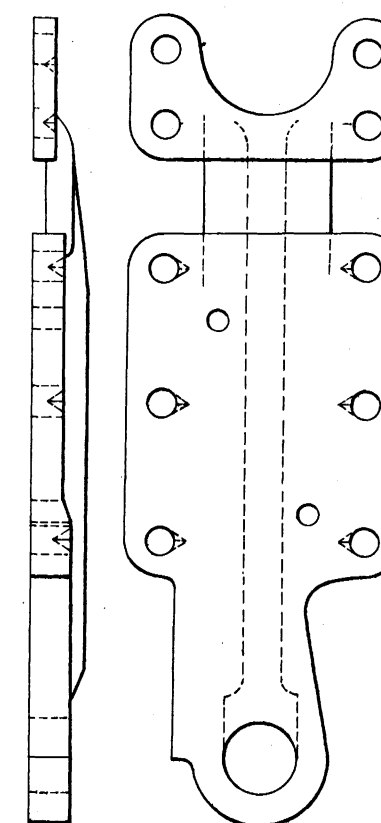



AFFUSTO DA CAMPAGNA DA 75 A

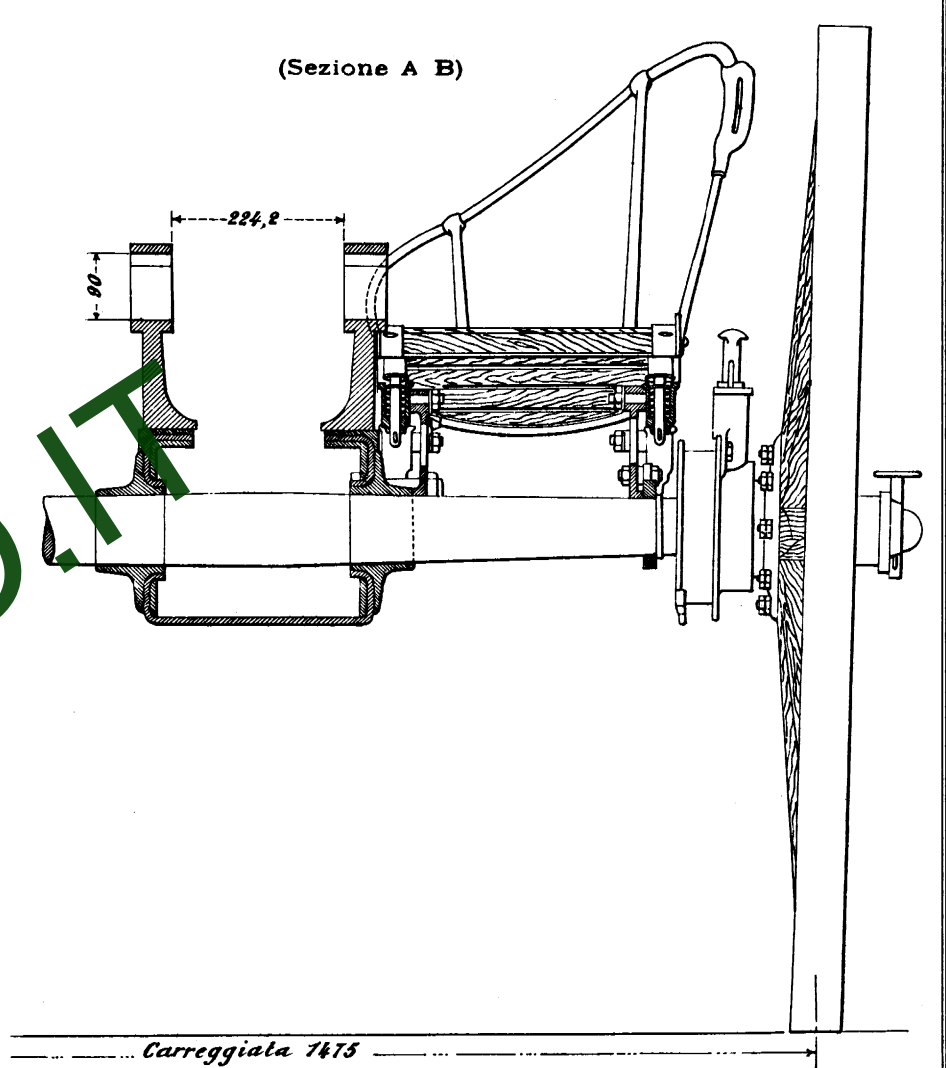
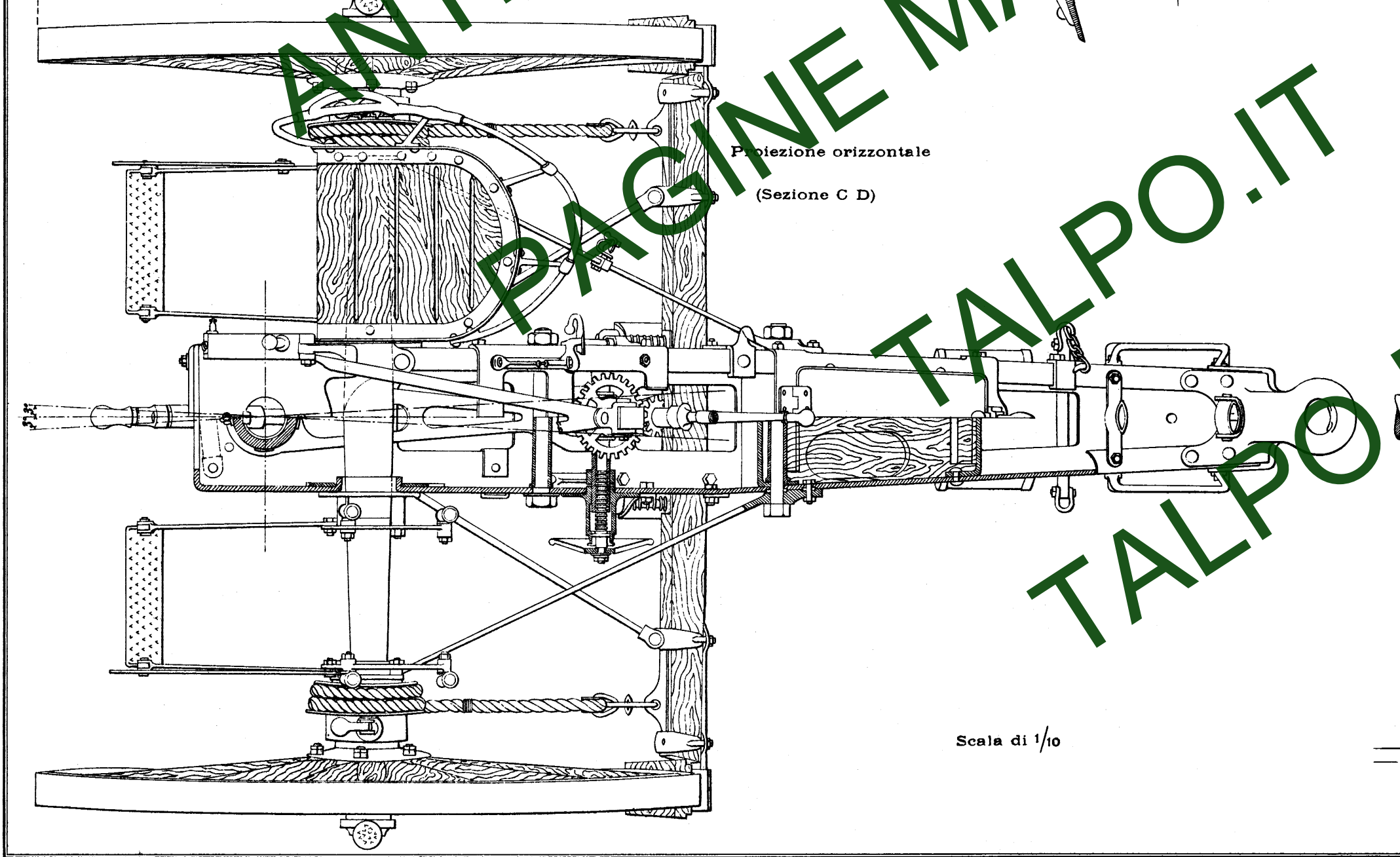
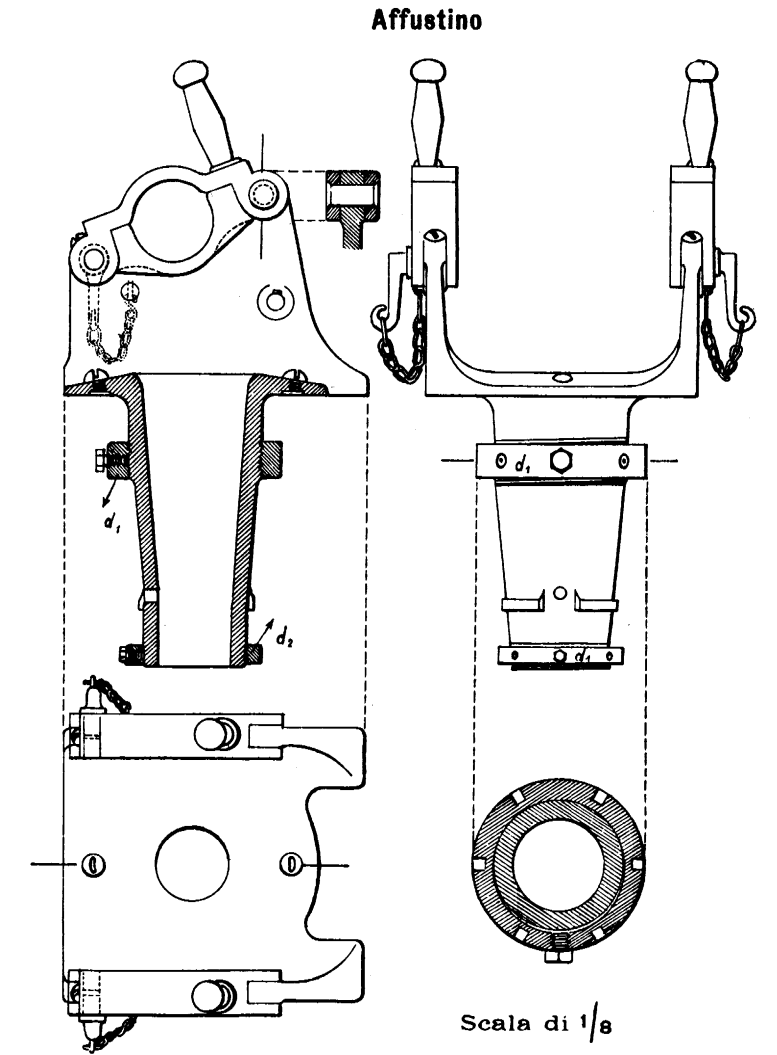
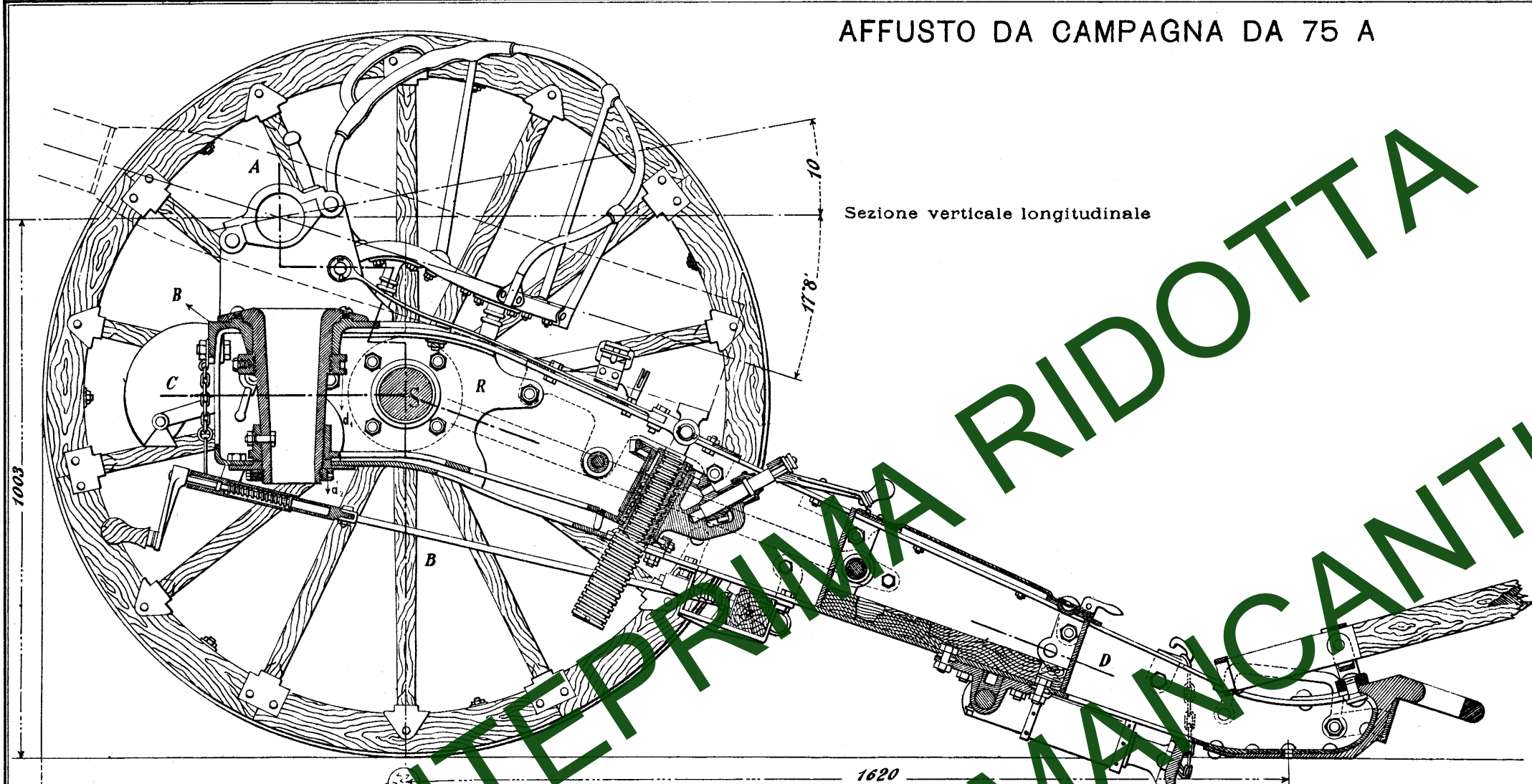



Congegno di punteria

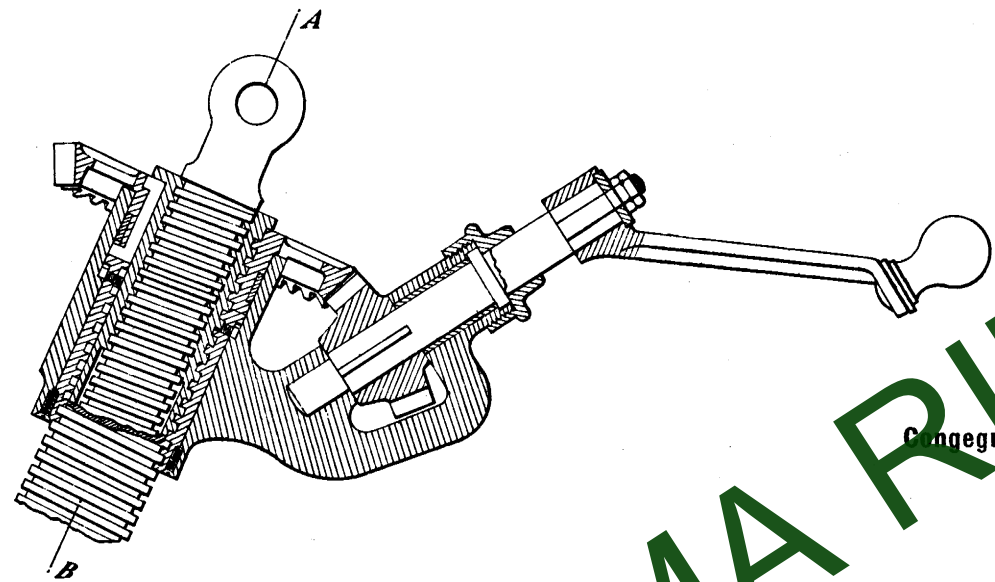

Freno di via

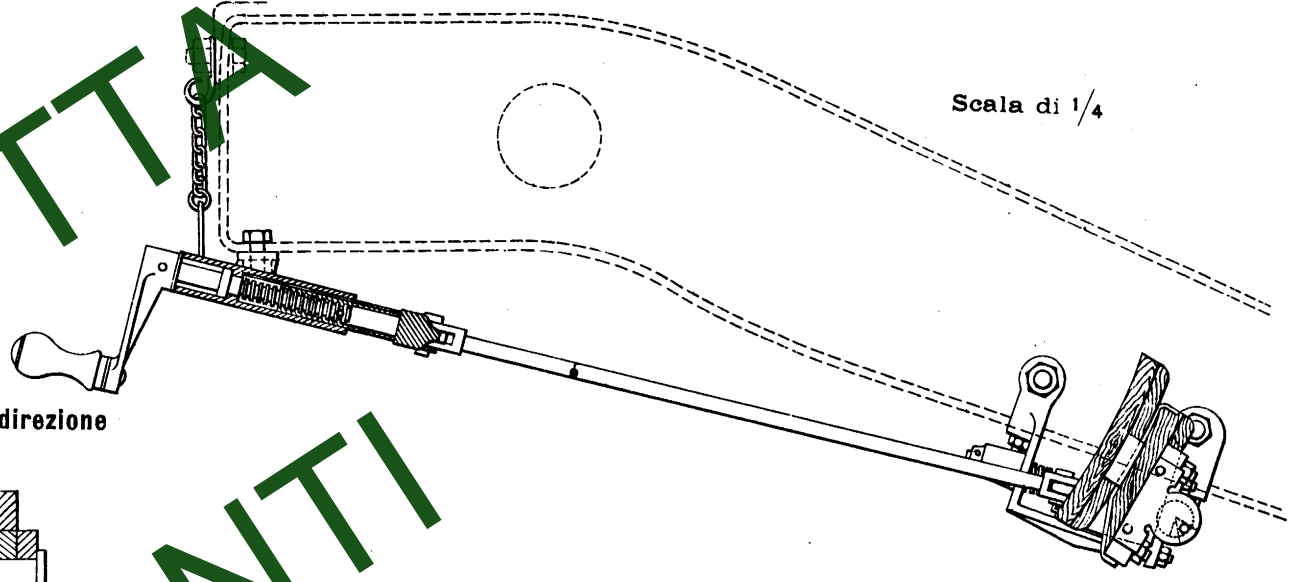

Scala di 1/4

Congegno di punteria e di direzione  
(Sezione A B)

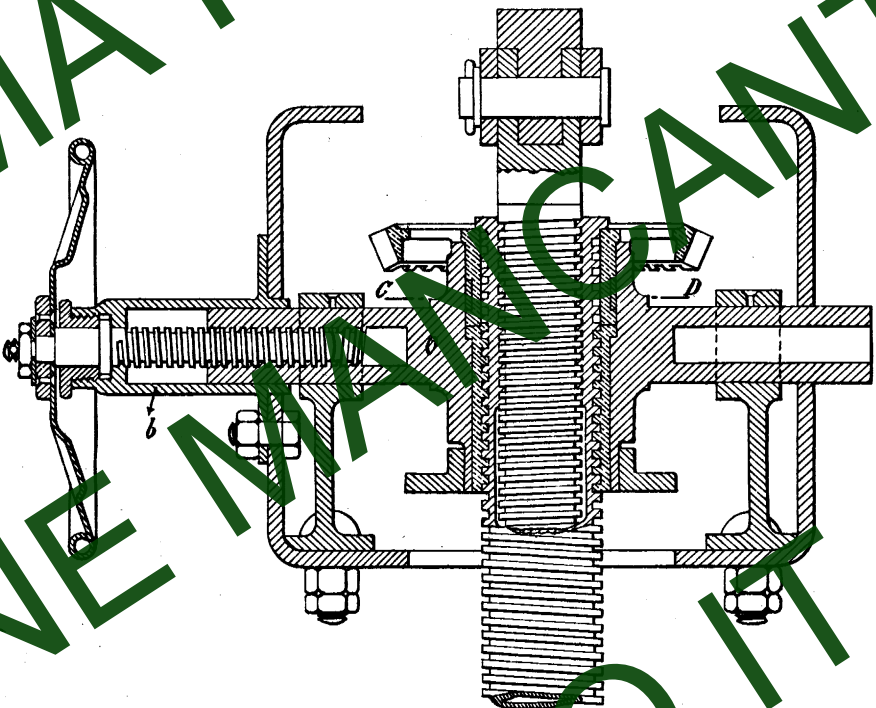

Applicazione del congegno di punteria  
Scala di 1/8

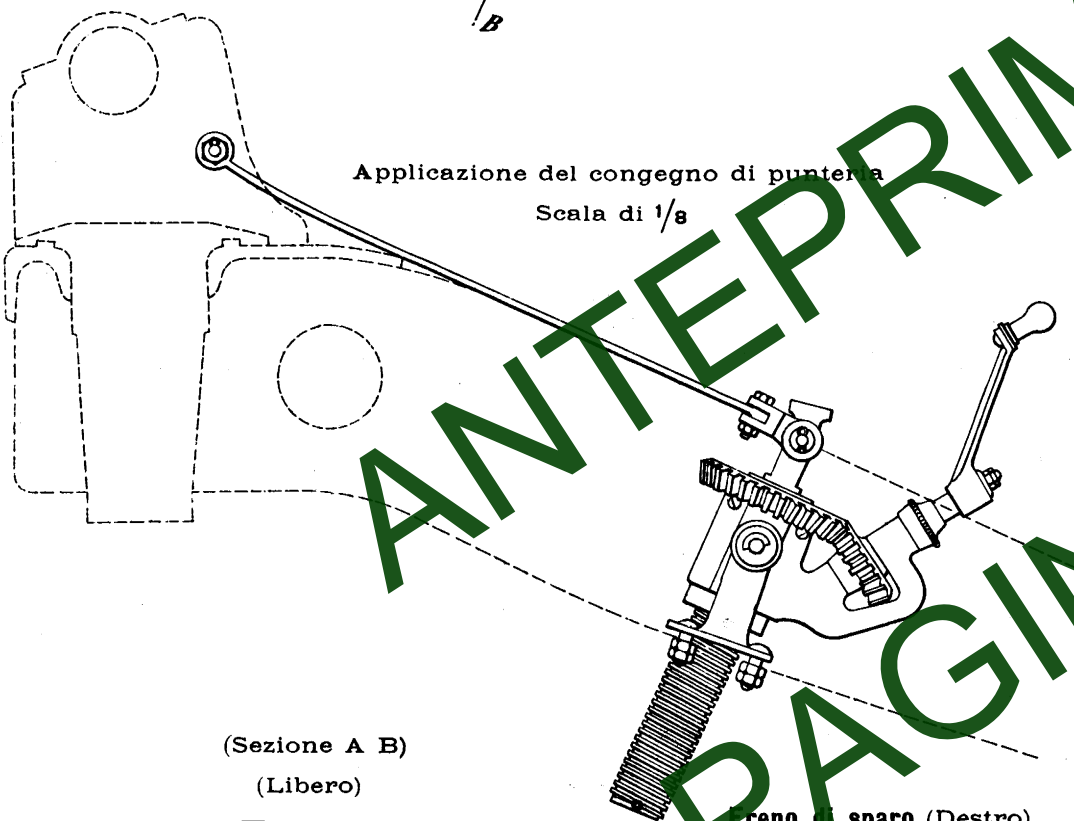

(Sezione C D)



(Sezione A B)  
(Libero)

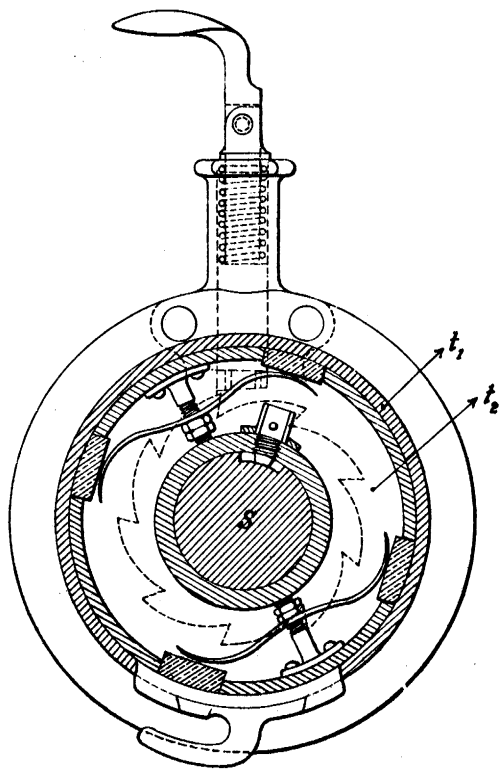

Freno di sparo (Destro)  
(Sezione C D)  
(In posizione di sparo)

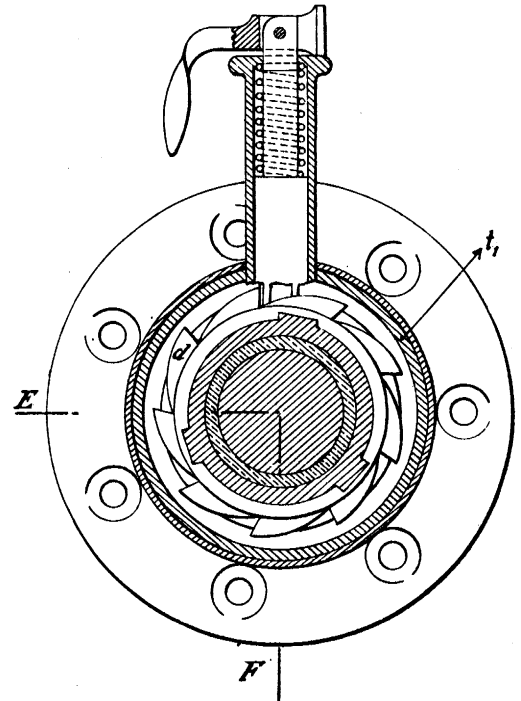

(Sezione E F)

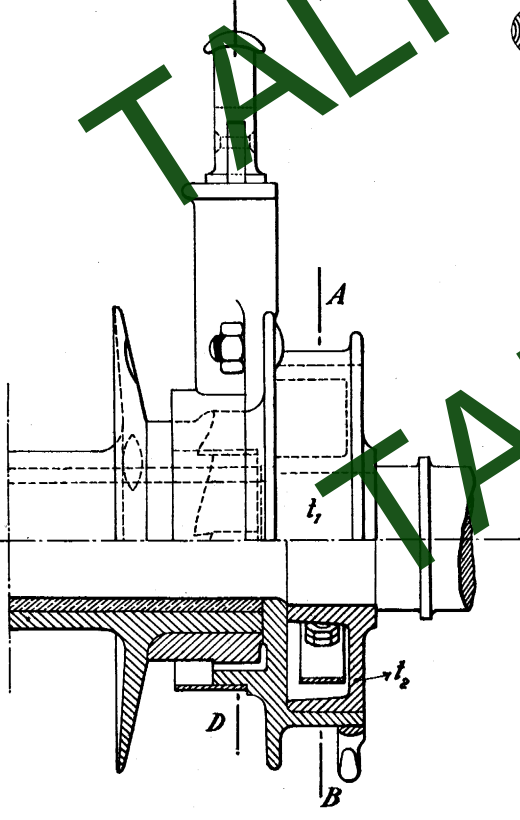

Scala di 1/4

Sospensione dei seggioli

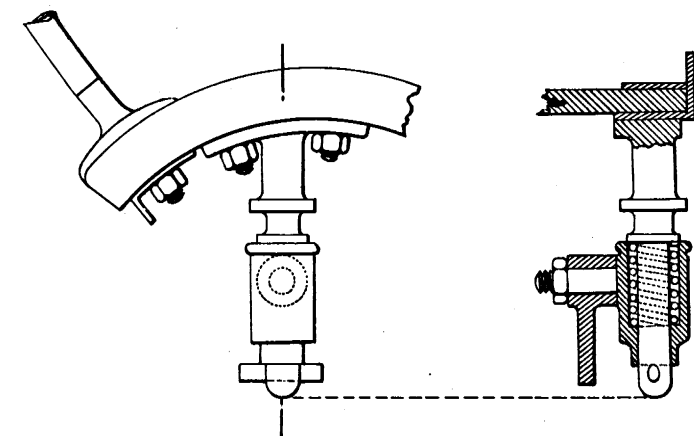

ANTEPRIMA RIDOTTA  
PAGINE MANCANTI  
TALPO.IT

Vomero Scala di 1/5

Avantreno da 75 A

Scala di 1/10

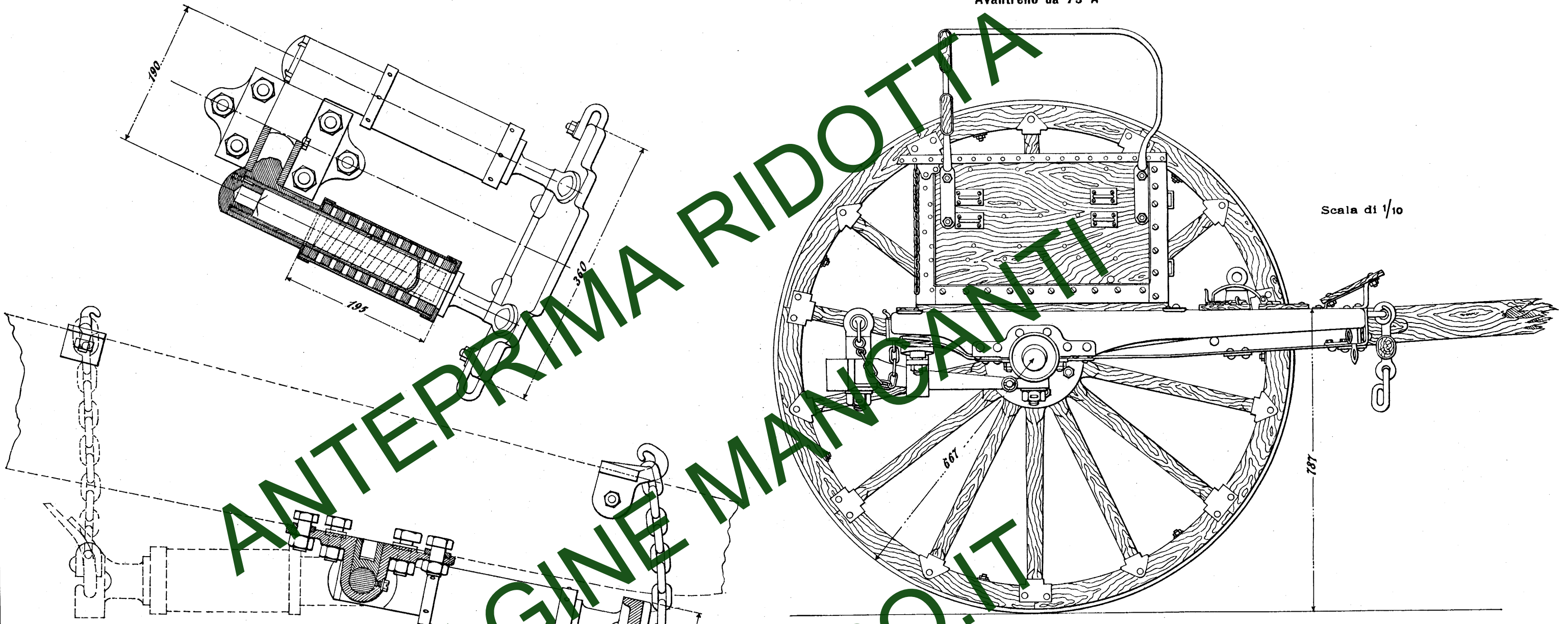

Avantreno da 75 A

Sezione longitudinale

Visto di dietro

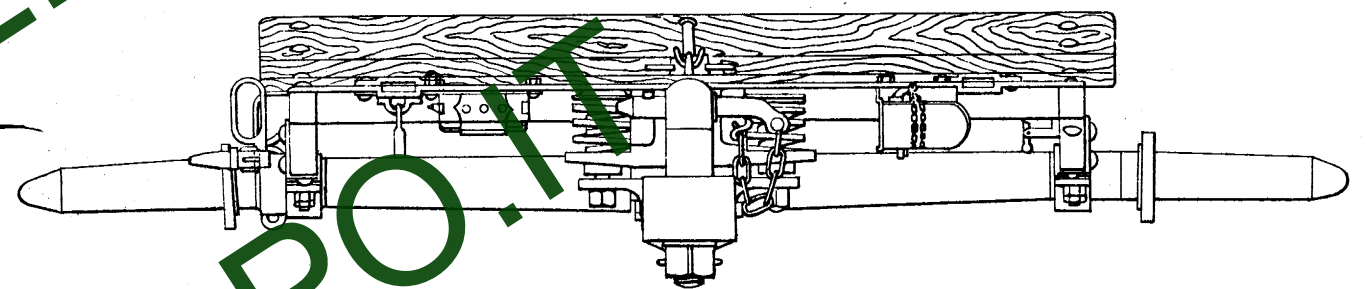
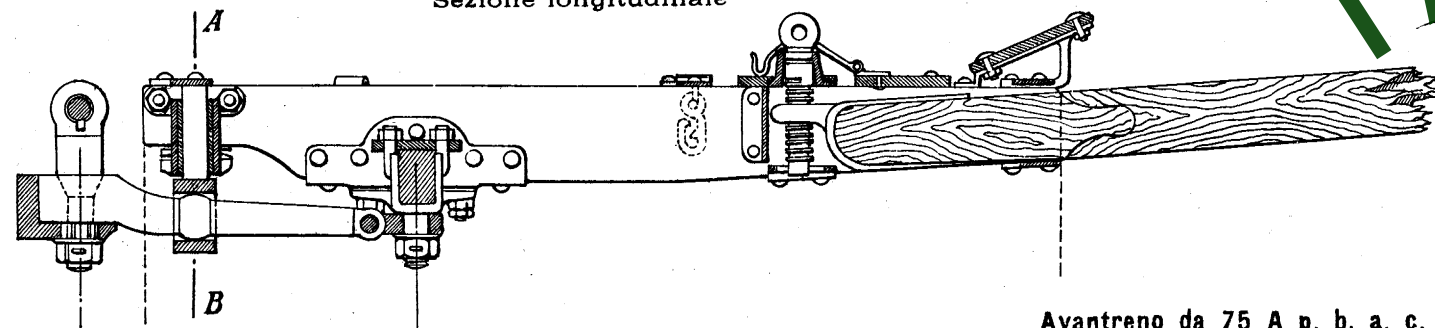

(Sezione A B)

Scala di 1/5

Vista di fianco

Avantreno da 75 A p. b. a. c.

Sezione longitudinale

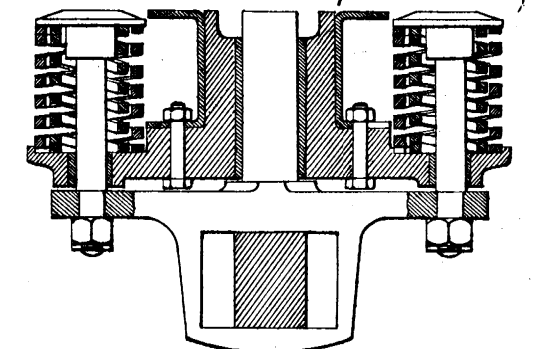
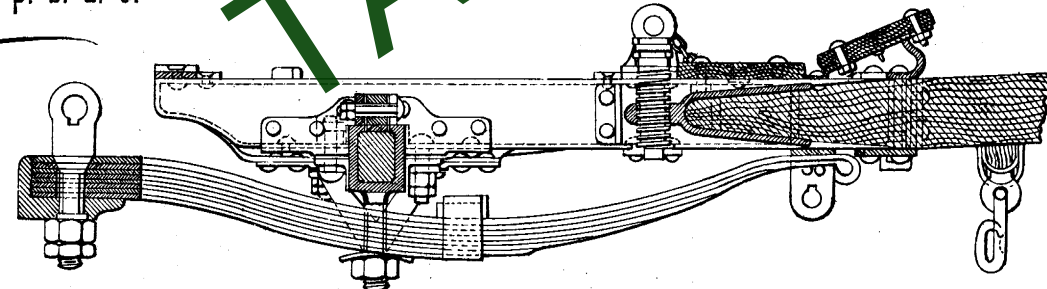
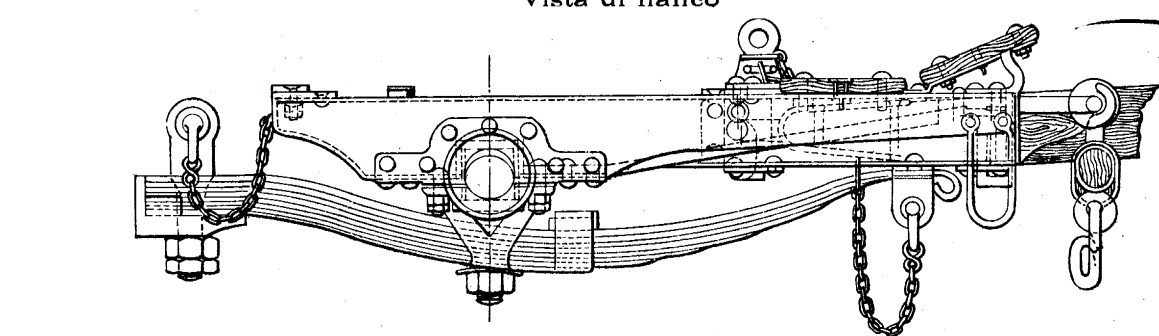



AFFUSTO  
Scala 1/15  
Sezione longitudinale

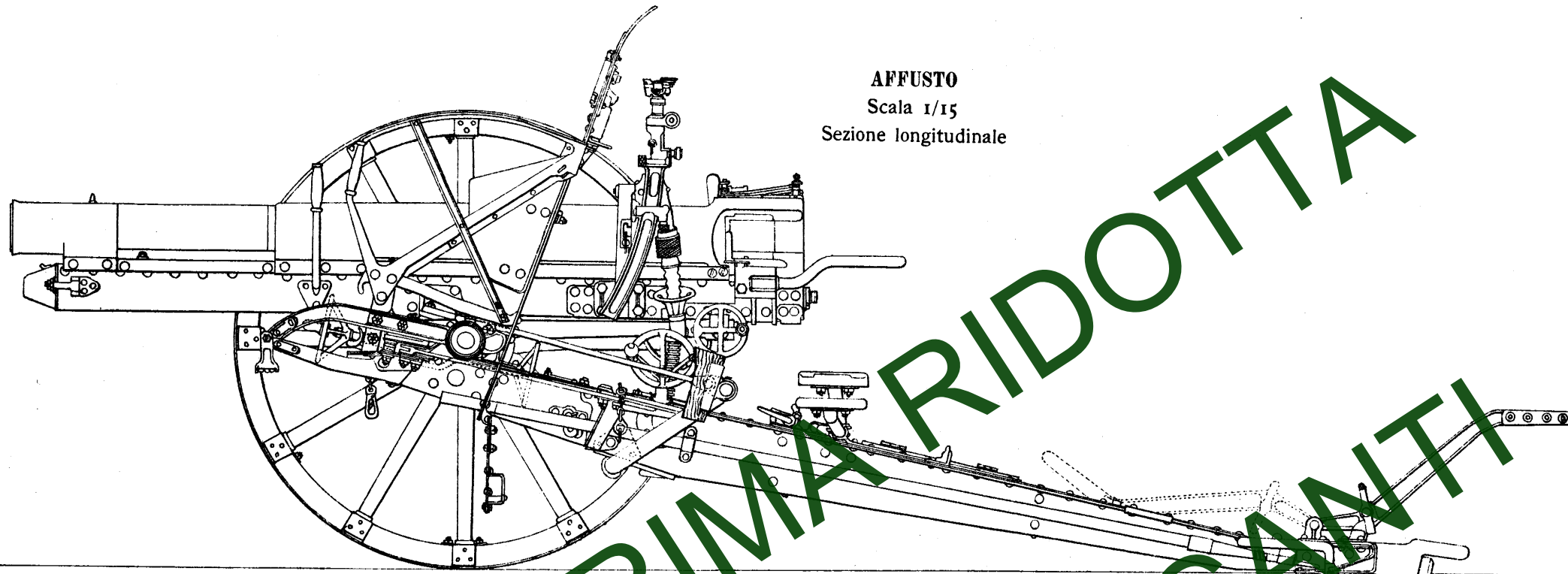

FRENO DI VIA DELL'AFFUSTO  
Scala 1/15

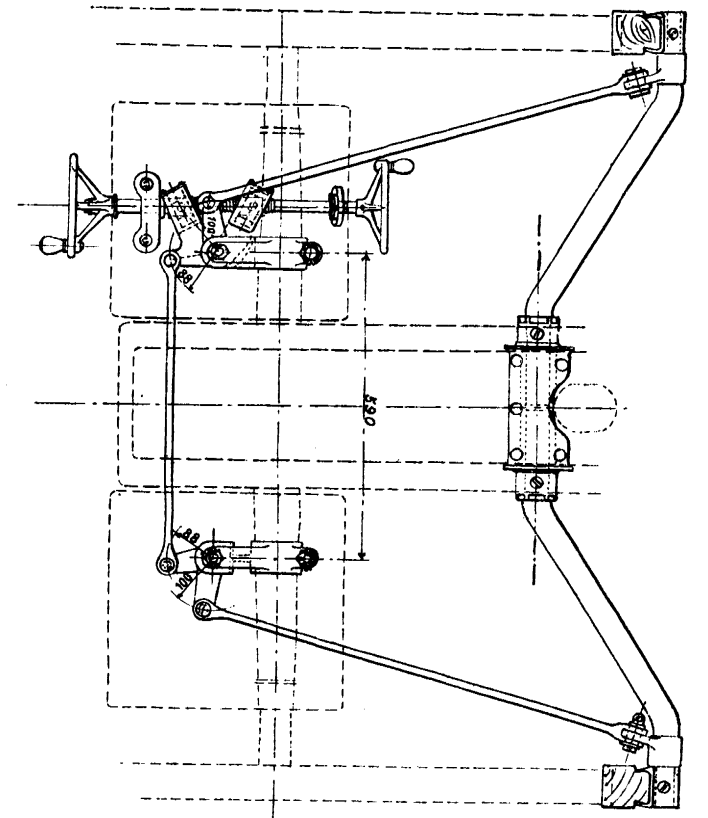

Sezione a a

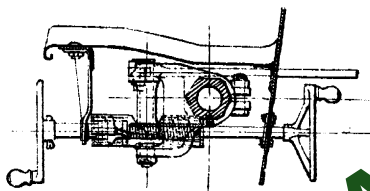

Unione a contrasto elastico dell'affusto

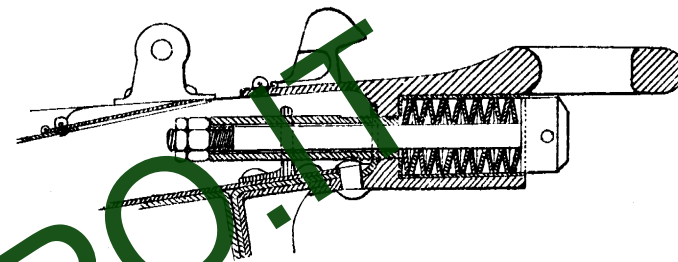

Sezione trasversale  
sull'asse della sala

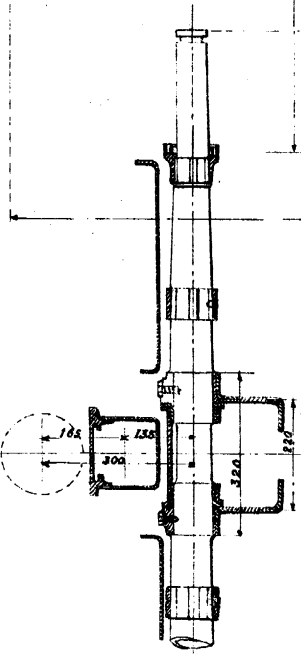

Visto di sopra senza culla e ingegni di puntamento

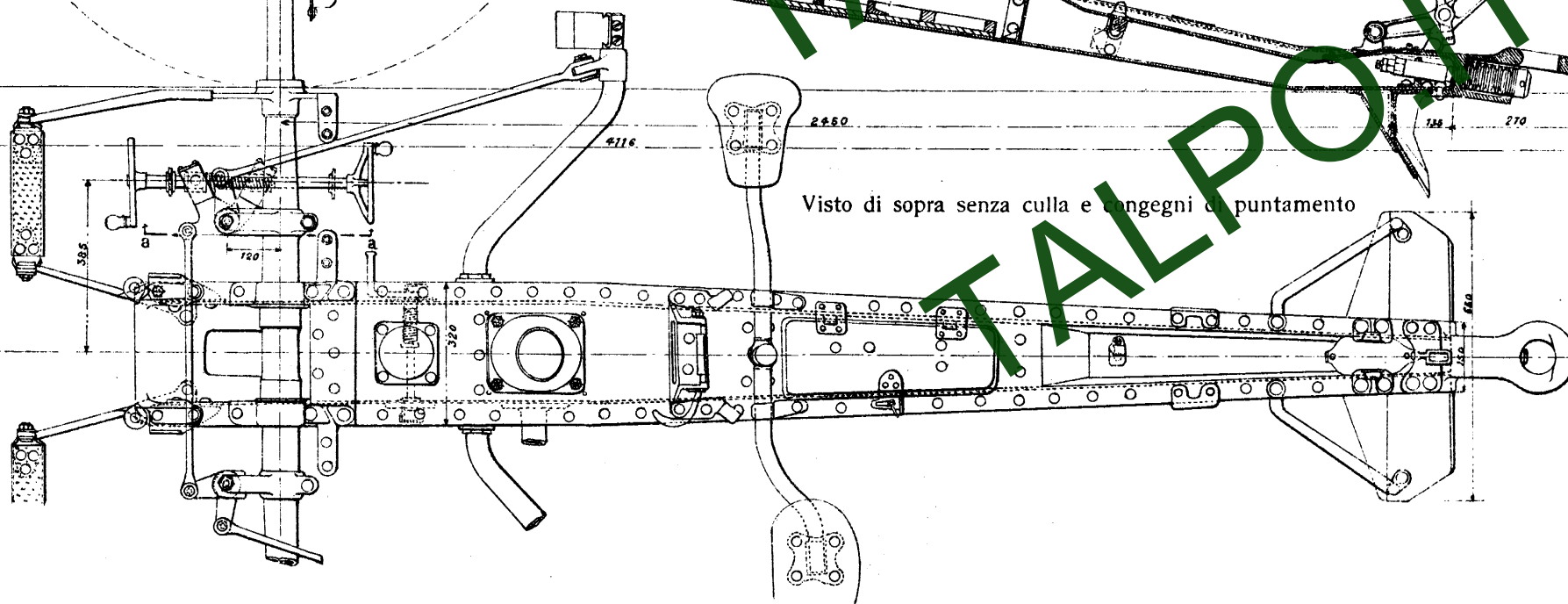

Stanghe del freno

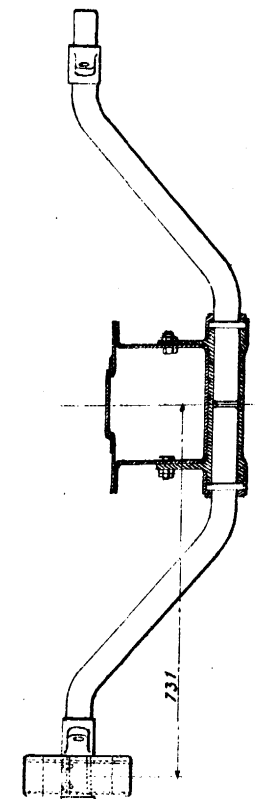

ANTEPRIMA RIDOTTA  
PAGINE MANCANTI  
TALPO.IT



ALZO  
Scala 1/4

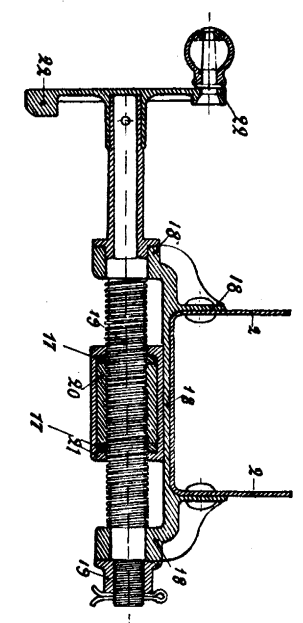
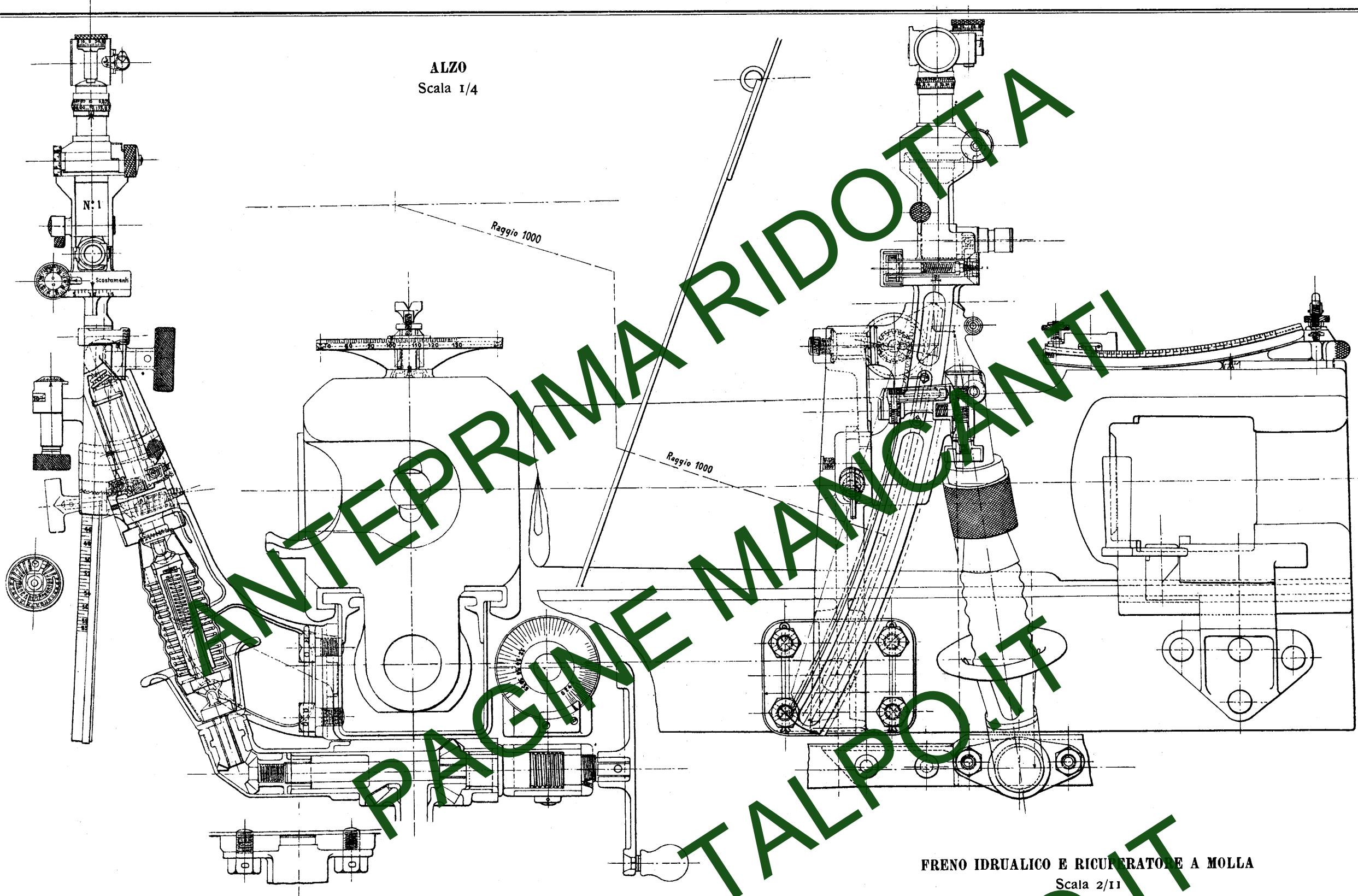

CONGEGNO DI DIREZIONE (Sezione A B)  
Scala 2/11

FRENO IDRUALICO E RICUPERATORE A MOLLA  
Scala 2/11  
Sezione orizzontale sull'asse del freno idraulico

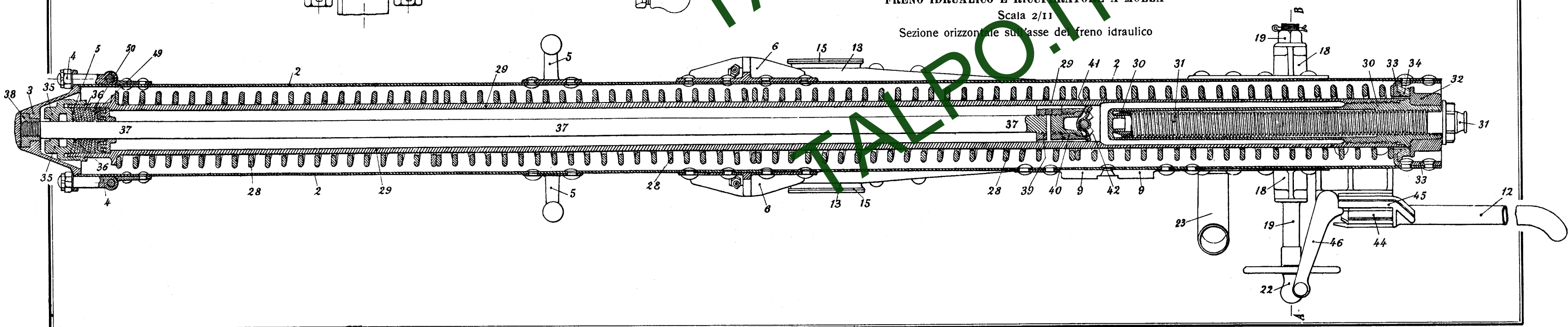

AFFUSTO DA DIFESA PER CANNONI DA 240, BASSO, CON SOTTO-AFFUSTO DEL N. 5

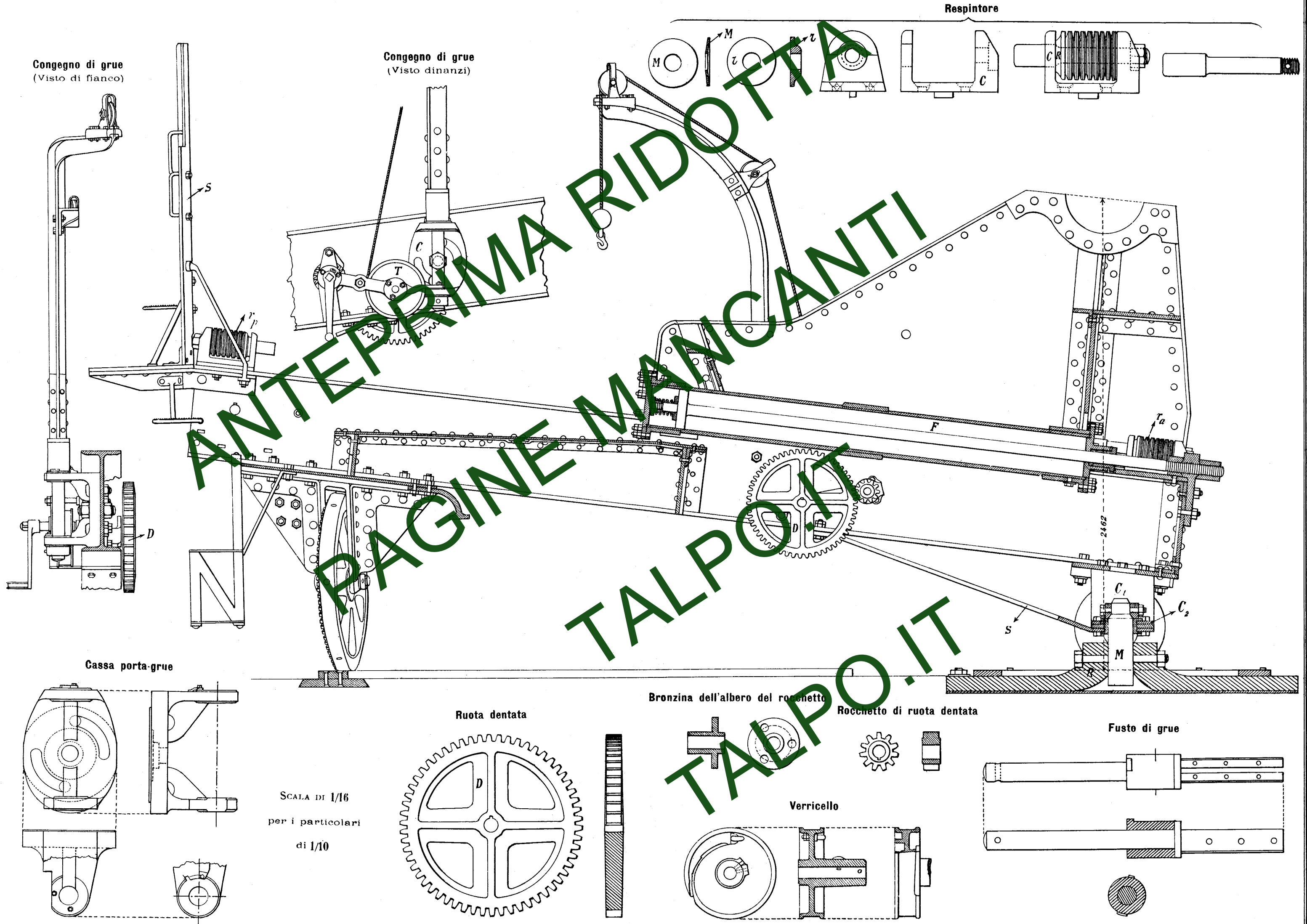

ANTEPRIMA RIDOTTA  
PAGINE MANCANTI  
TALPO.IT



Particolari del congegno di punteria

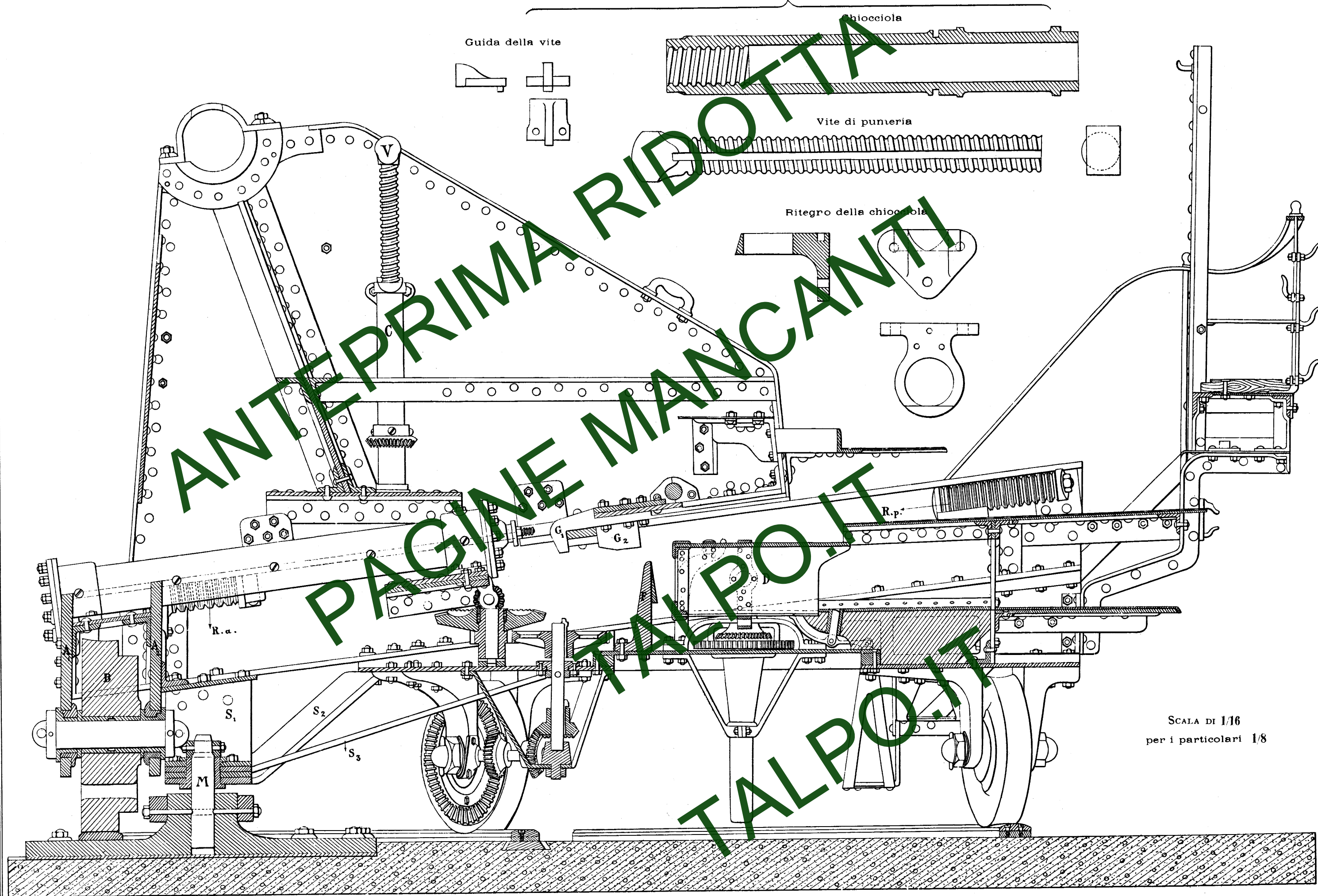

ANTEPRIMA RIDOTTA  
PAGINE MANCANTI  
TALPO.IT

SCALA DI 1/16  
per i particolari 1/8



Particolari del freno idraulico

Premi-Stoppa

Valvola ad orecchie del fusto di stantuffo

Fondo del freno

Coperchio

Molla doppia dell'embolo di stantuffo

Vite della molla doppia

SCALA DI 1/5

SCALA DI 1/4

SCALA DI 1/2

Plastrina della valvola

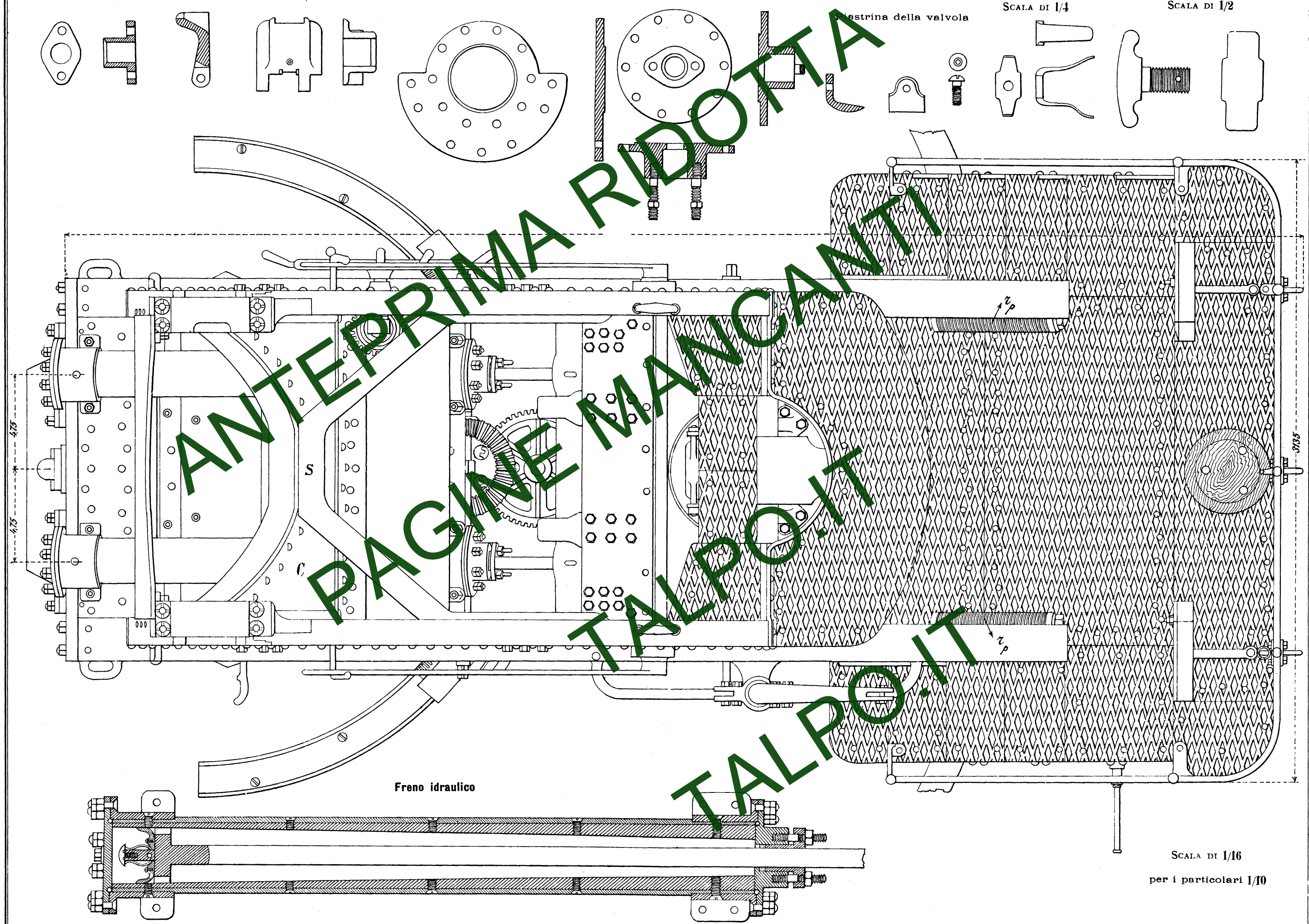

Freno idraulico

SCALA DI 1/16  
per i particolari 1/10







Affusto articolato a perno centrale, per cannone da 149 C (R. M.)

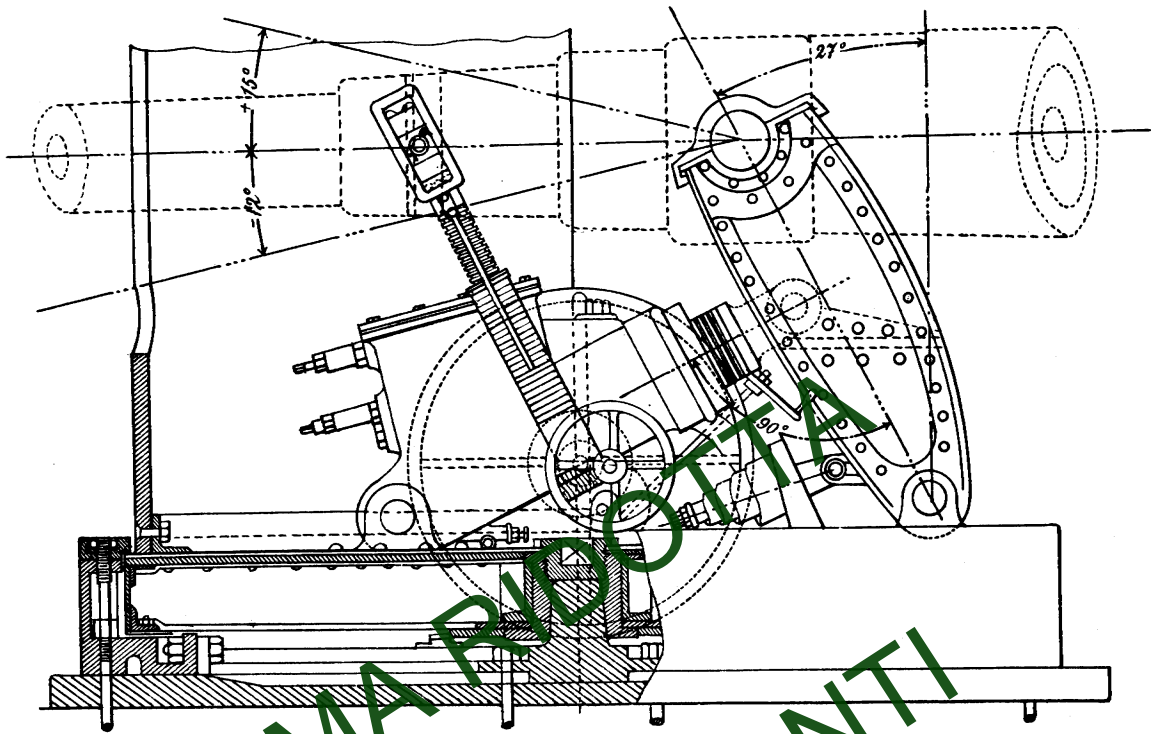

Affusto a cassone Mod. 1886, per cannone da 120 A (R. M.)

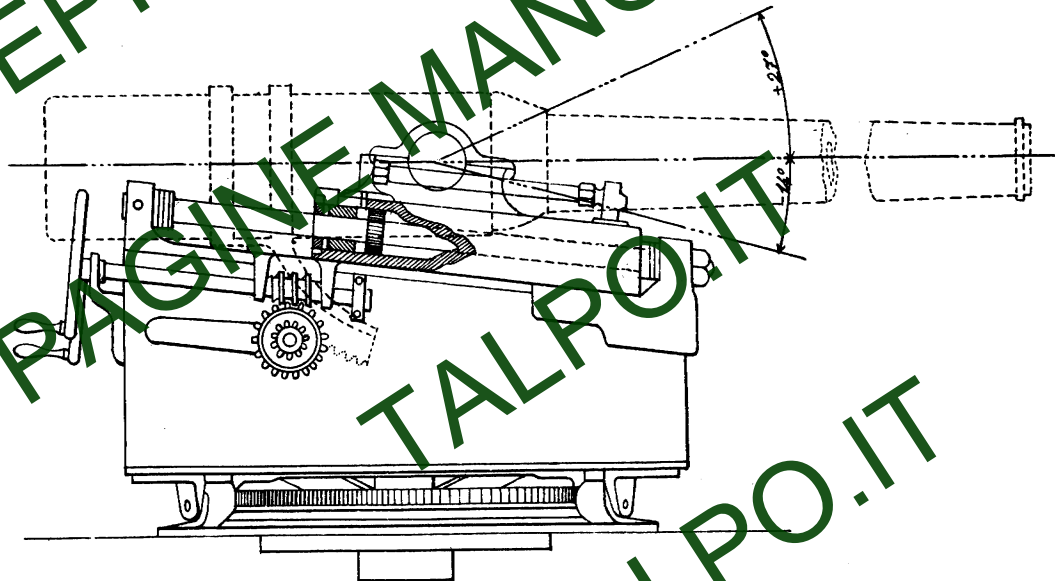

Affusto per cannone da 57 H (R. M.)

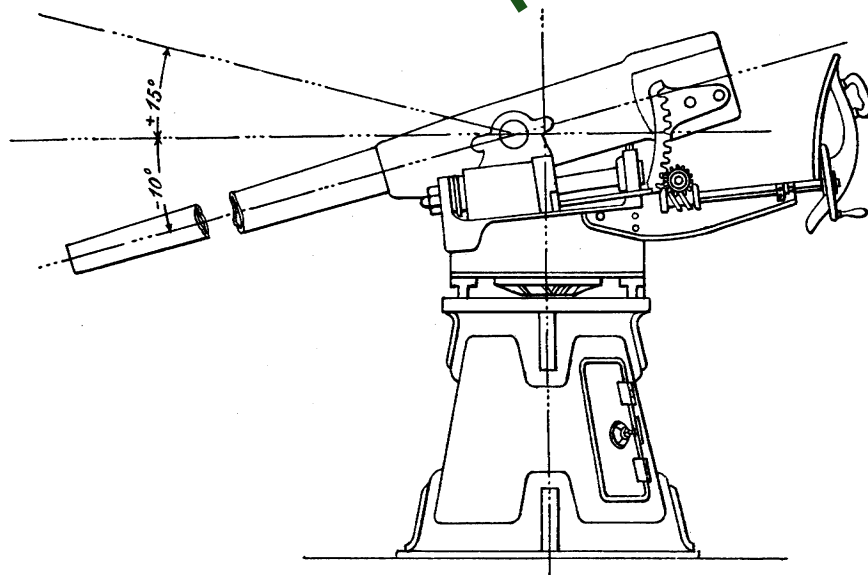

### AFFUSTO A SCOMPARSA PER CANNONE DA 57, IN TORRETTA CORAZZATA

Sezione mediana passante per l'asse del pezzo  
(Affusto sollevato)

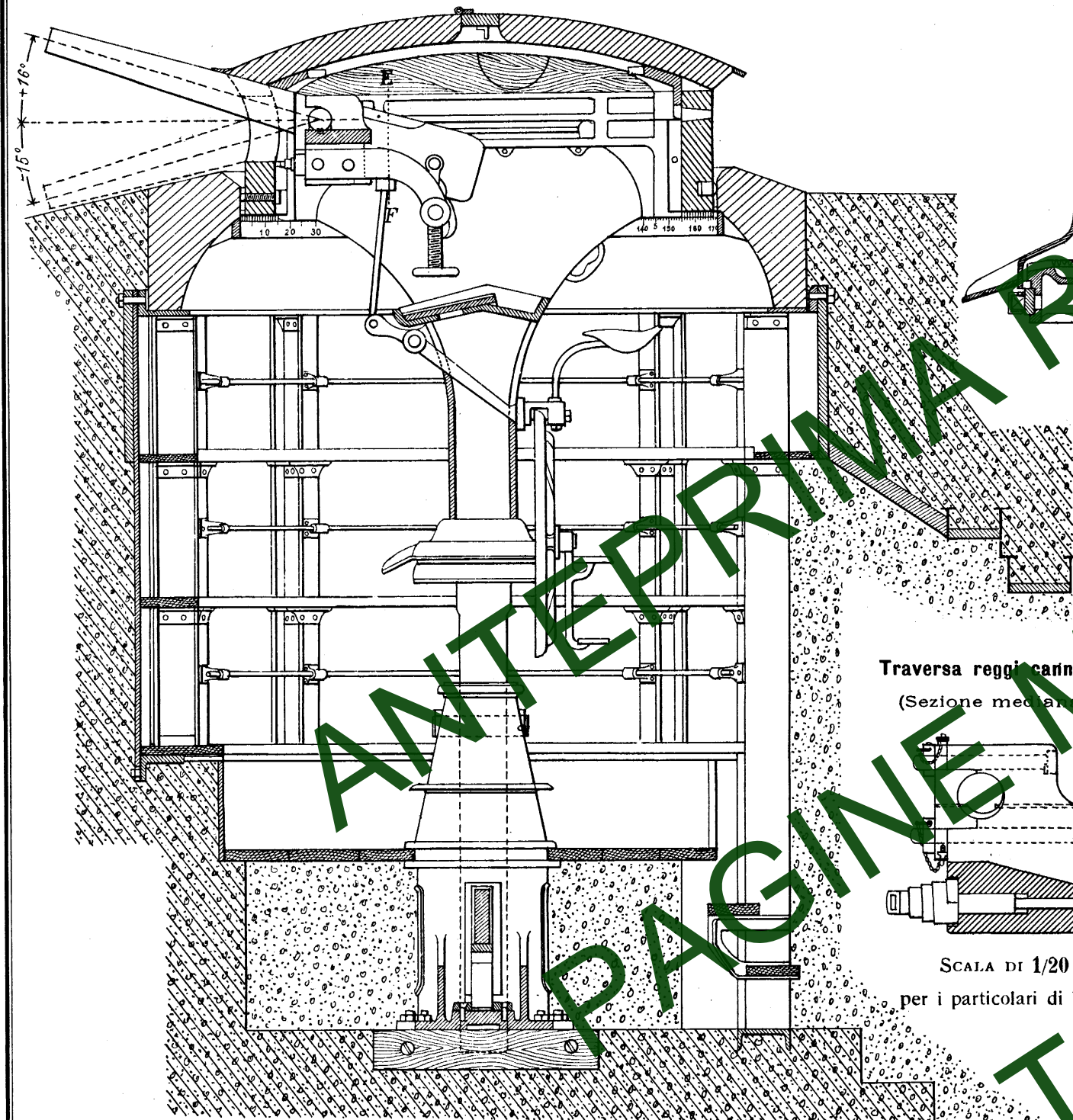

Congegno per la direzione  
(Sezione A B)

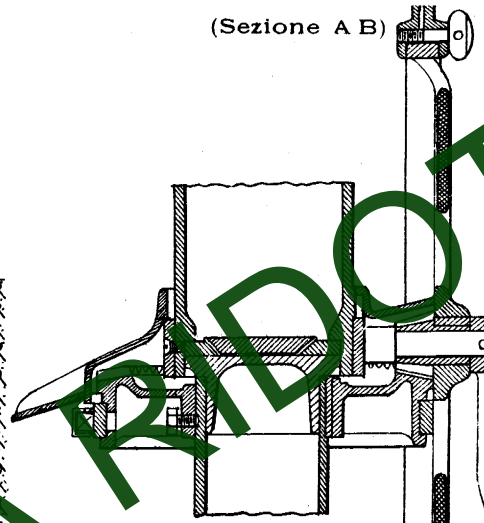

Sezione mediana con un piano normale all'asse del pezzo  
(Affusto abbassato)

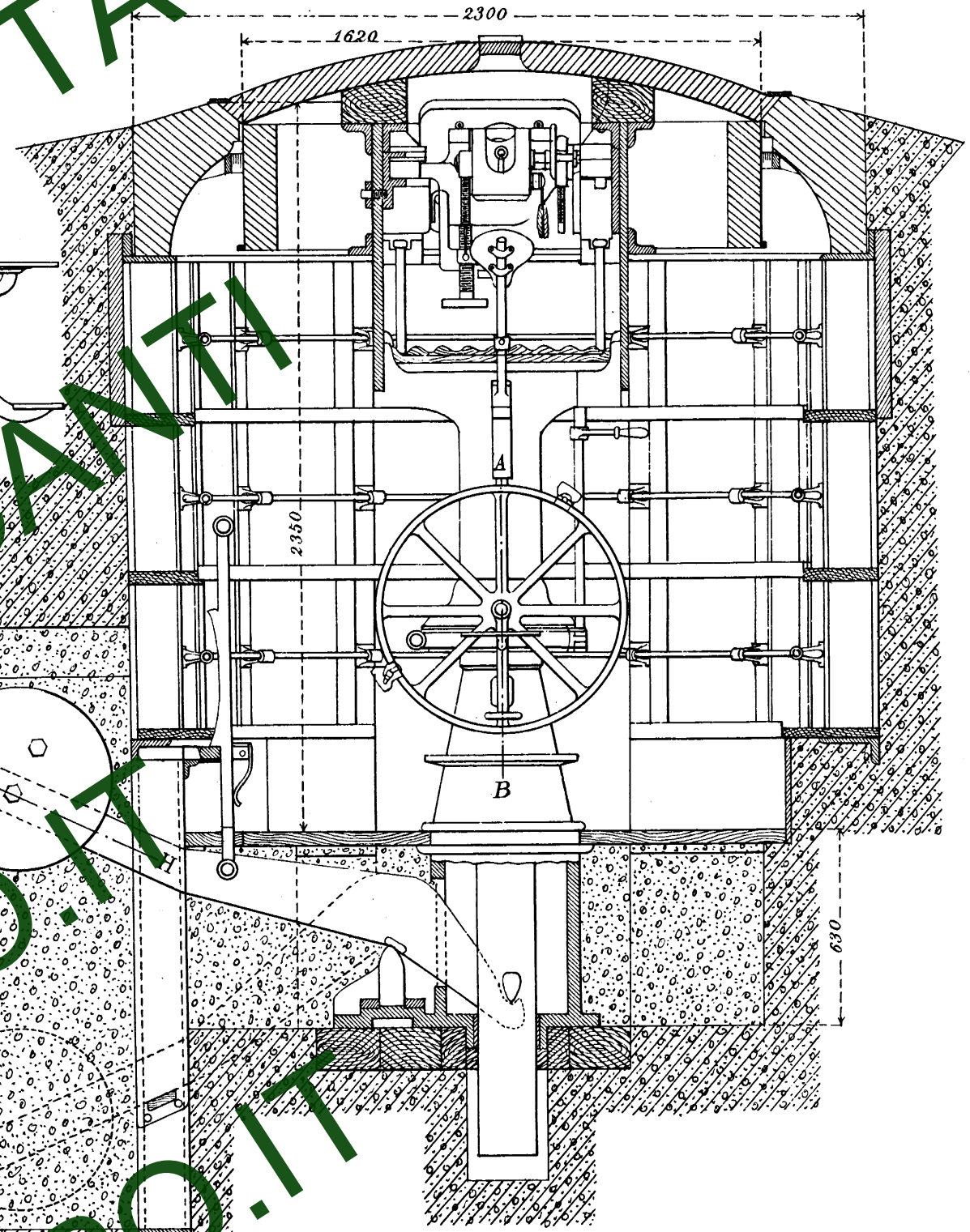

Traversa reggi cannone  
(Sezione mediana)

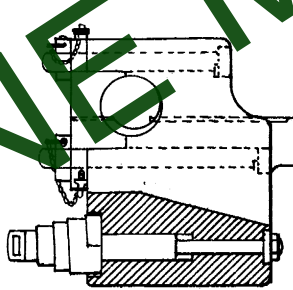

SCALA DI 1/20  
per i particolari di 1/10

Cannone a caricamento rapido da 57, per torrette corazzate

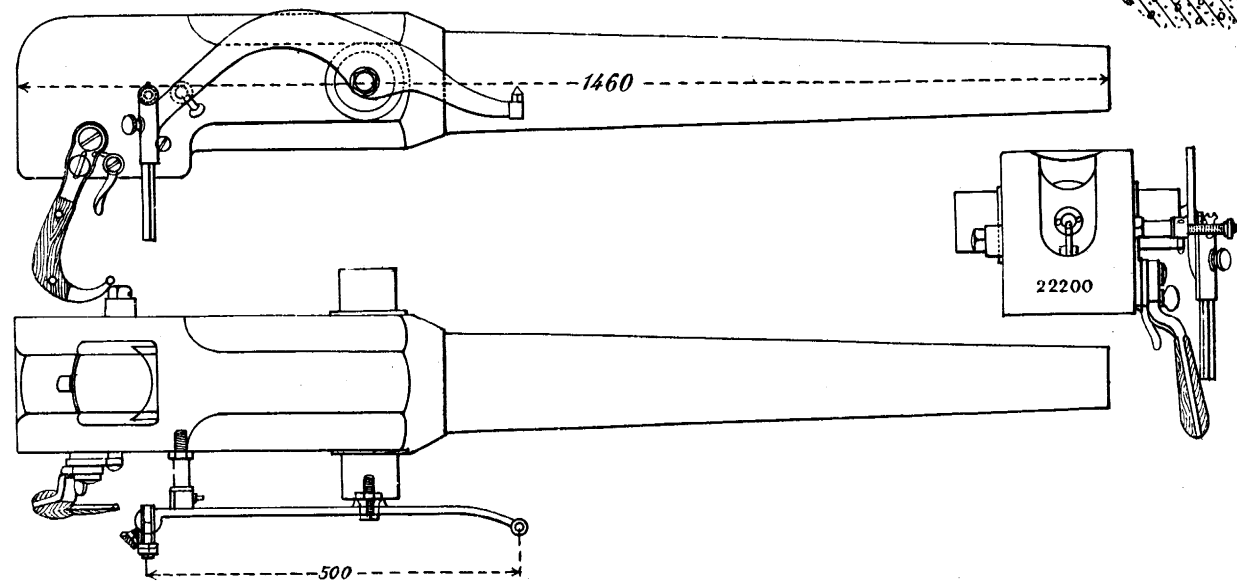

Congegno per la soppressione del rinculo  
(Visto dall'alto)

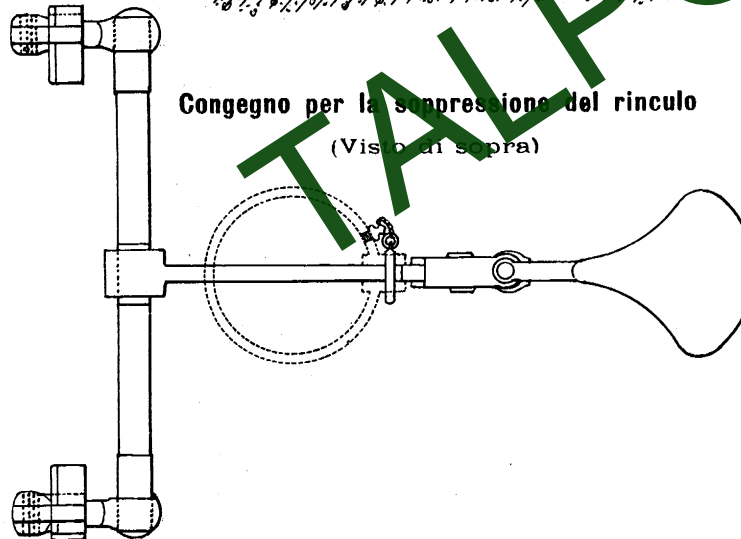

(Sezione GH)  
SCALA DI 1/20

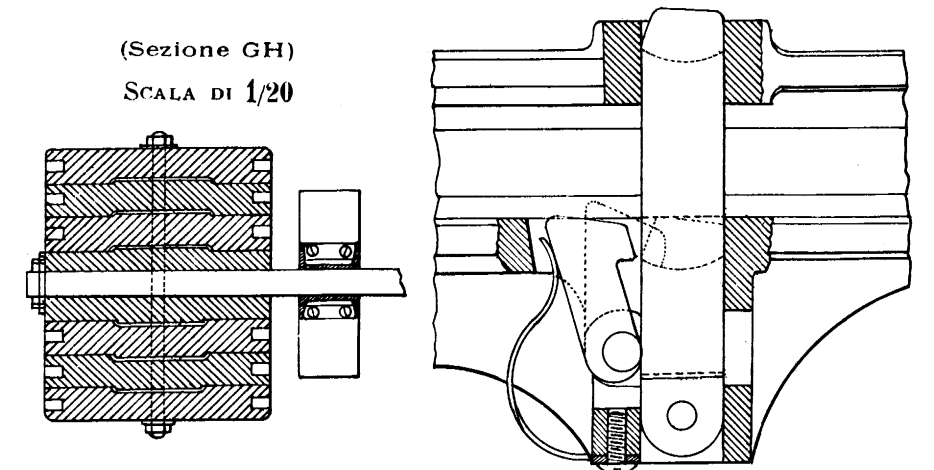

(Sezione EF) SCALA DI 1/4

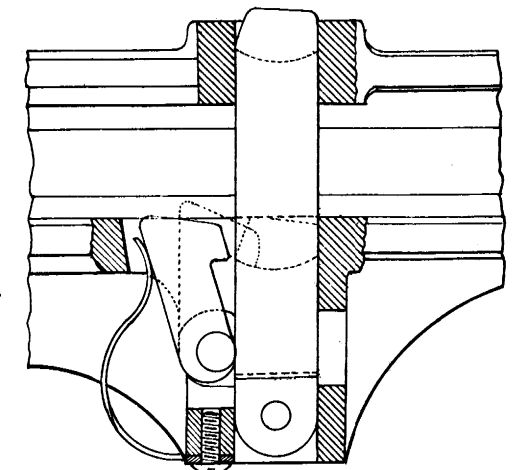



TORRE CORAZZATA DA 400

Sistemazione del perno centrale e degli apparecchi di direzione e di messa in moto

Sezione verticale

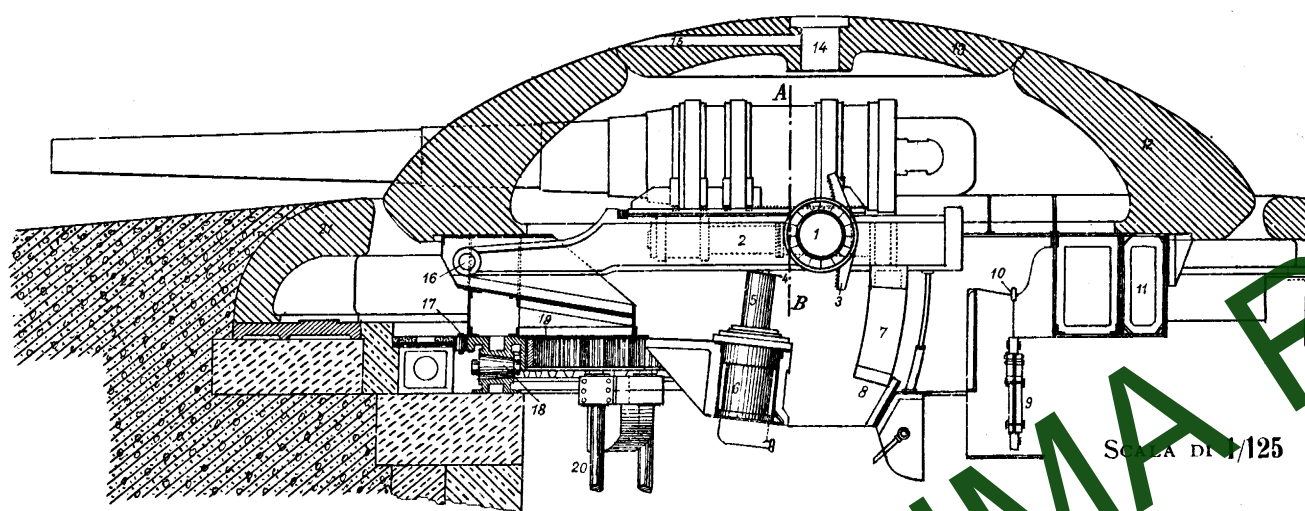

LEGGENDA

- |                                |   |
|--------------------------------|---|
| 1 Voluta.                      | 12 Piastra di corazza (spicchio).       |
| 2 Freno.                       | 13 Piastra di copertura.                |
| 3 Dentiera arcuata.            | 14 Cabina.                              |
| 4 Incavo.                      | 15 Feritoia per telemetro.              |
| 5 Pistone.                     | 16 Perno di rotazione del sott'affusto. |
| 6 Cilindro di elevazione.      | 17 Rullo verticale.                     |
| 7 Guide ad arco.               | 18 Rullo tronco-conico orizzontale.     |
| 8 Arresti.                     | 19 Dentiera.                            |
| 9 Elevatori di porta mazzioni. | 20 Albero di rotazione.                 |
| 10 Girelle di rullo.           | 21 Avancorazza.                         |
| 11 Tamburo o parrante.         | 22 Calcestruzzo.                        |

Freno del rinculo

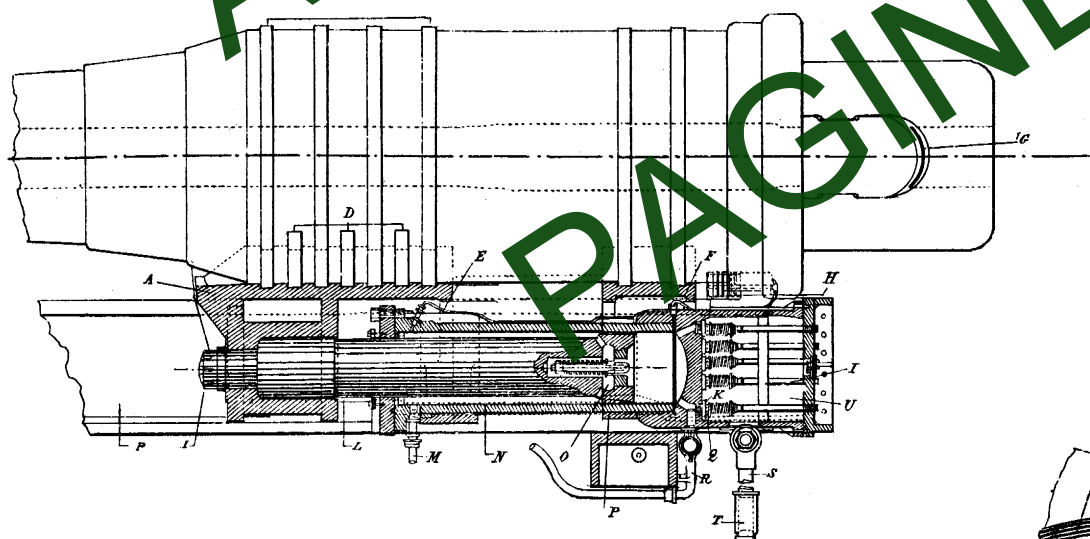

Sezione A B

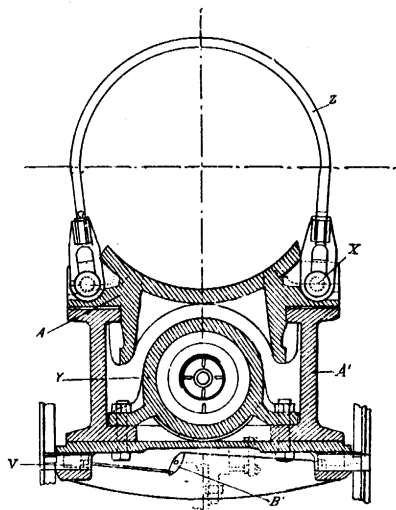

Visto di fianco

Visto di fronte

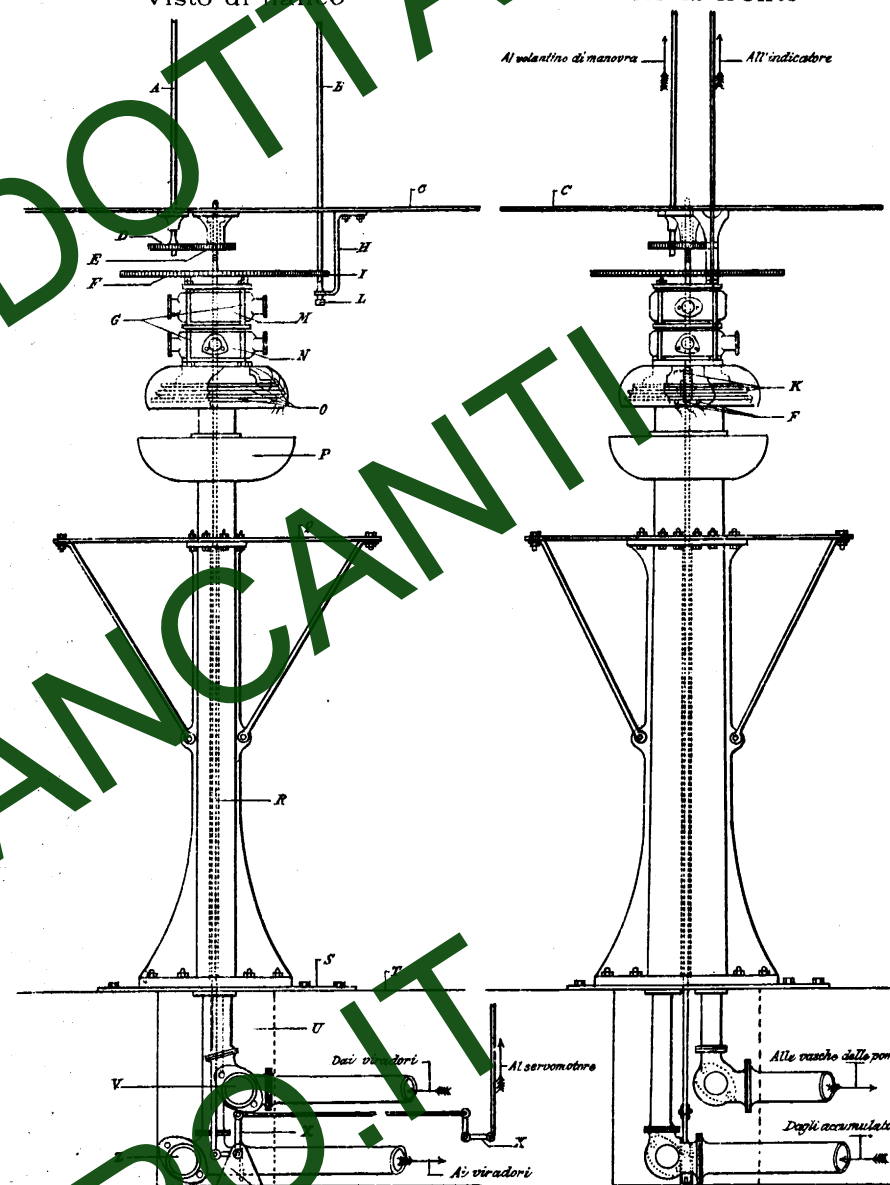

LEGGENDA

- |   |
|---|
| A Albero trasmettitore dell'apparecchio di messa in moto. |
| B Albero dell'apparecchio di direzione.                   |
| C Lamiera di fondo.                                       |
| D Ruota dentata.  |
| E Ruota dentata con chiocciola.                           |
| F Disco dentato fisso.                                    |
| G Tiranti.  |
| H Sopperto.   |
| I Rocchetto dentato.                                      |
| K Serrafil.   |
| L Vite regolatrice e di pressione.                        |
| M Raccordo di pressione girevole.                         |
| N Raccordo di scarico girevole.                           |
| O Prese di corrente.                                      |
| P Raccogliatore di spurghi.                               |
| Q Pianerottolo fisso.                                     |
| R Albero ricevitore dell'apparecchio di messa in moto.    |
| S Piastra di fondazione.                                  |
| T Piano dei carrelli.                                     |
| U Canale.   |
| V Tubazione di scarico.                                   |
| X Leva ad angolo.   |
| Y Sopperto.   |
| Z Tubatura di pressione.                                  |

SCALA DI 1/40

Congegno per il maneggio dell'otturatore

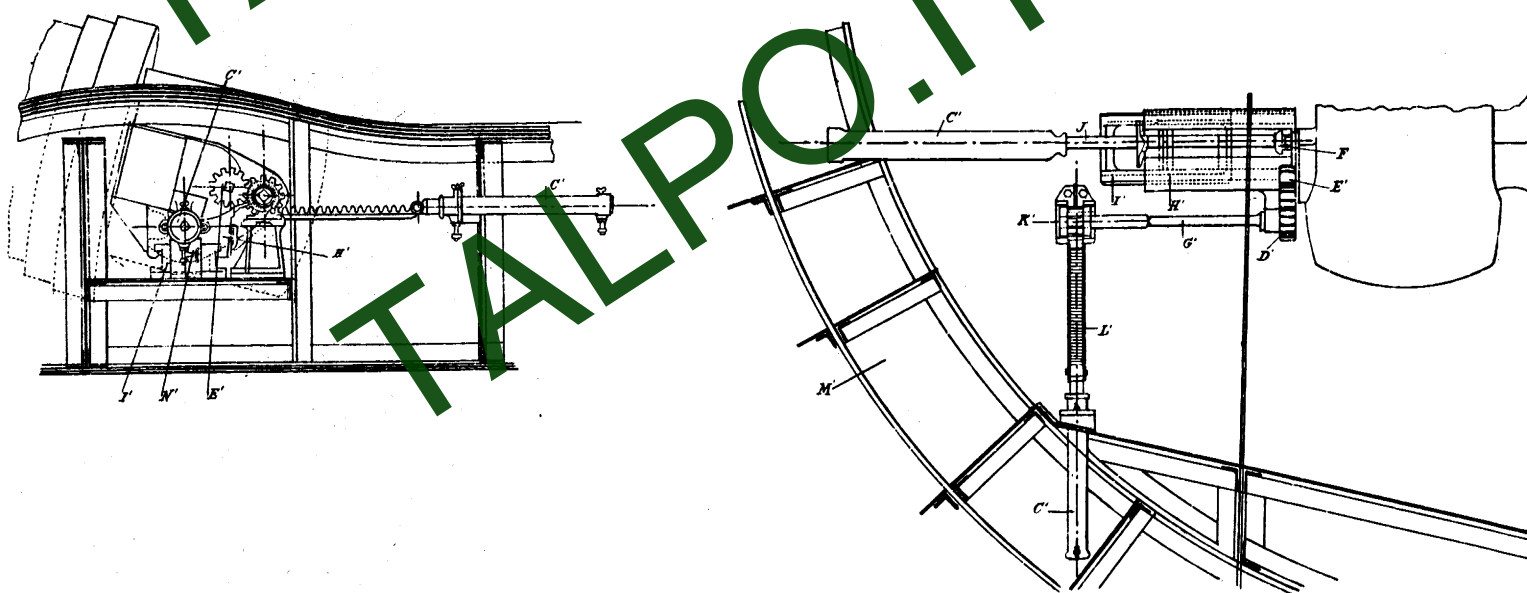



# AFFUSTO DA 120 PER TORRE CORAZZATA

Sezione mediana passante pel piano dell'asse

SCALA DI 1/20

Particolari della graduazione della torre  
(SCALA DI 1/10)

Asta reggi  
Treccia metallica con  
occhello e giunto  
(SCALA DI 1/5)

Ruota dentata del congegno di direzione

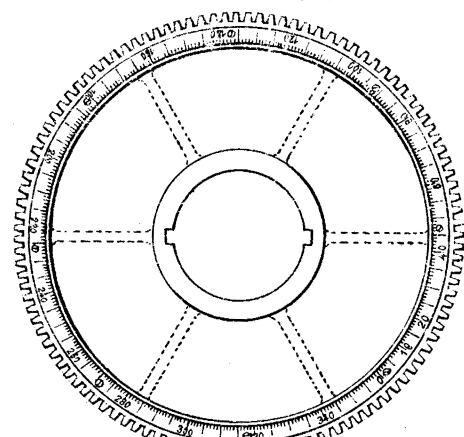

Castello di guida  
(Visto di sopra)

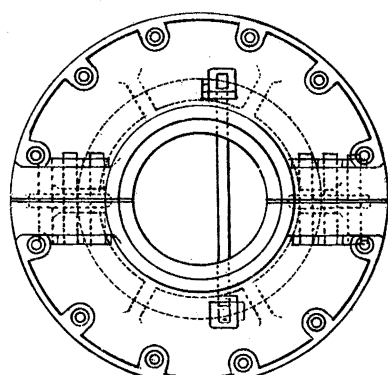

Contrappeso (Visto di sopra)

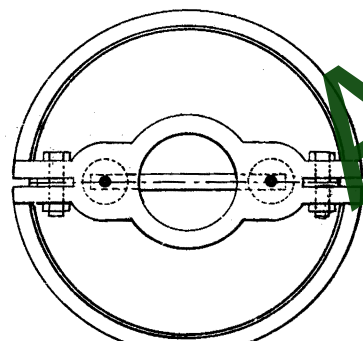

Chiocciola della  
colonna perno

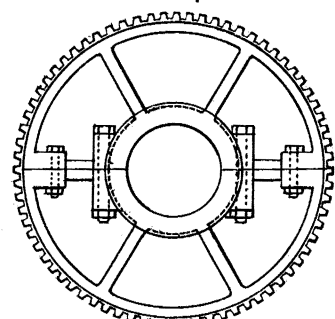

Piastra di base

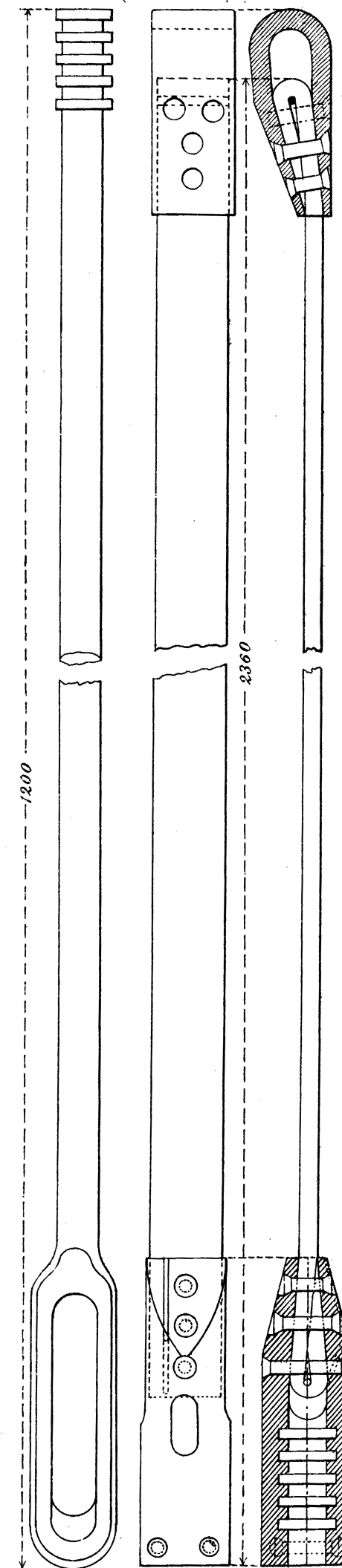
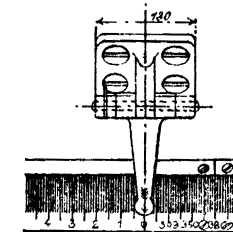
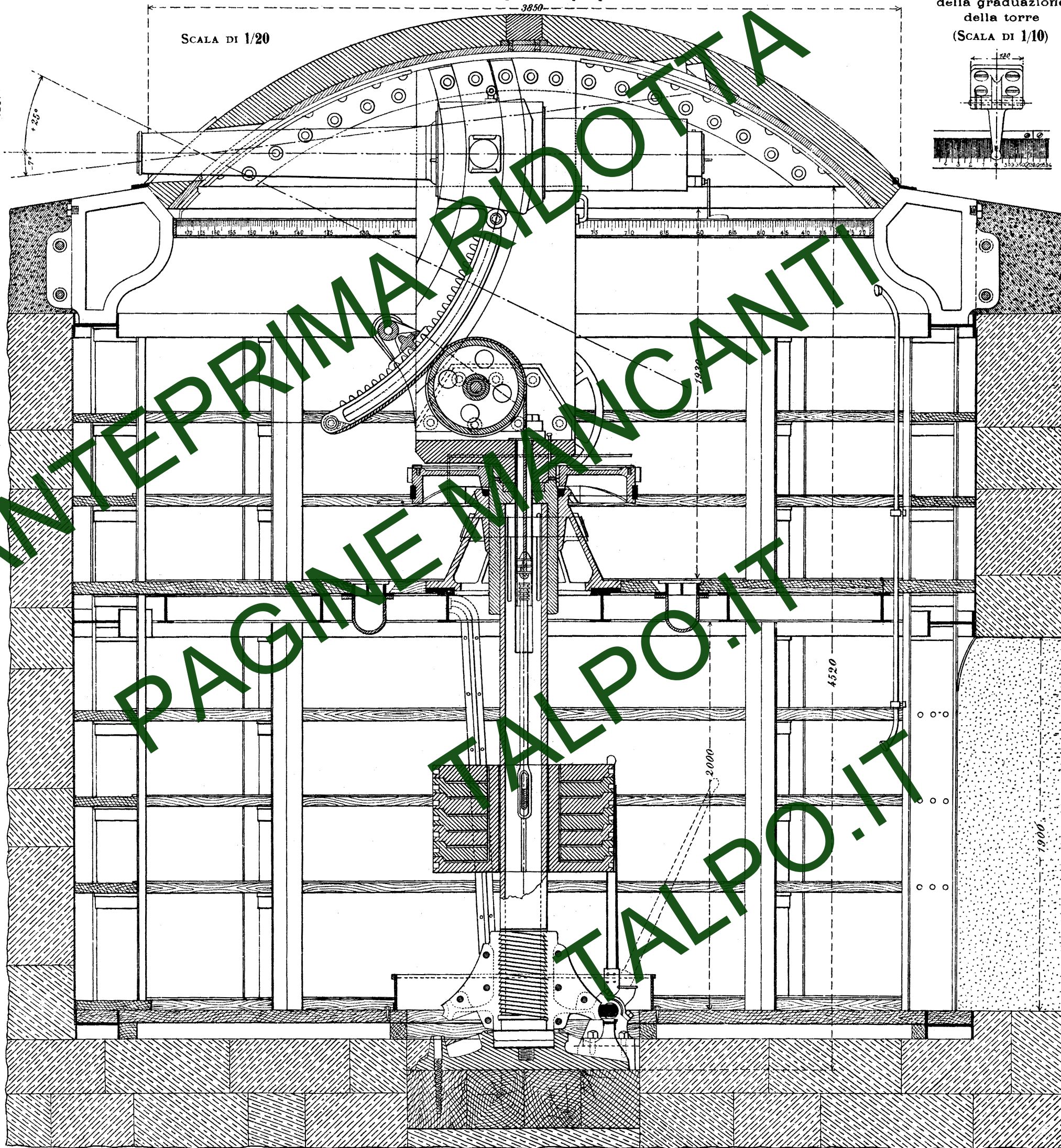
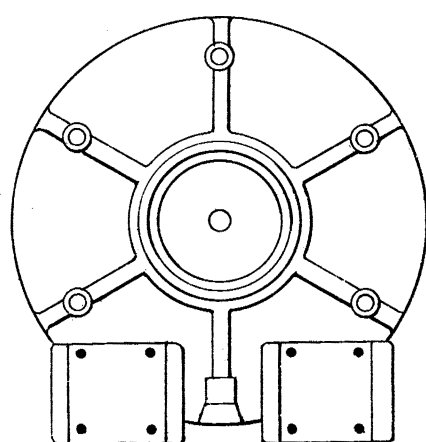

ANTEPRIMA RIDOTTA  
PAGINE MANCANTI  
TALPO.IT



# AFFUSTO DA 120 PER TORRE CORAZZATA

Sezione mediana normale al piano dell'asse

Freno a nastro del congegno per la rotazione dell'affusto  
Unione delle due parti dell'anello mediante la vite regolatrice

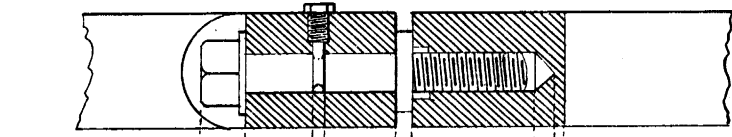

(SCALA DI 1/5)

Manovella a doppio rocchetto

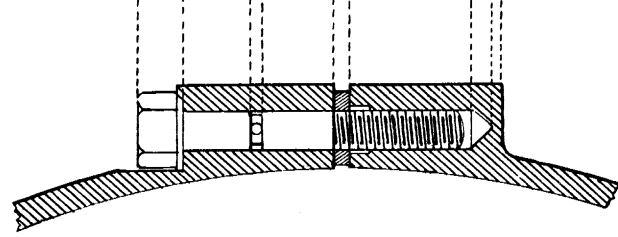

Unione delle due parti dell'anello coll'albero della manovella

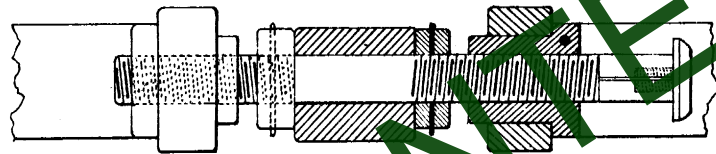
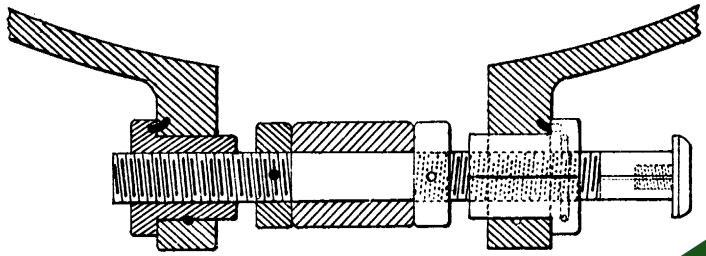

Ventilatore (visto di fianco)

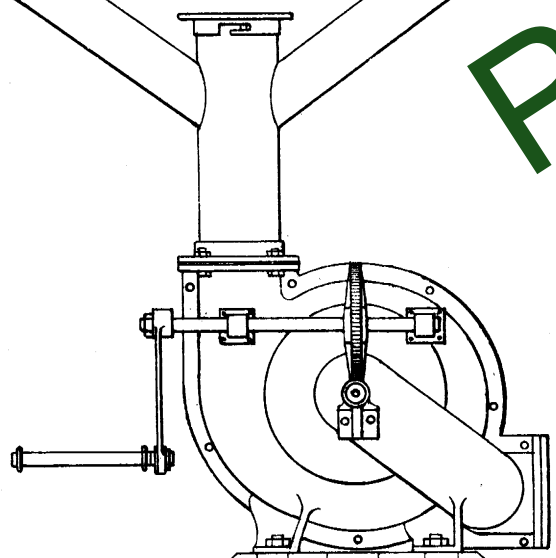

(SCALA DI 1/20)

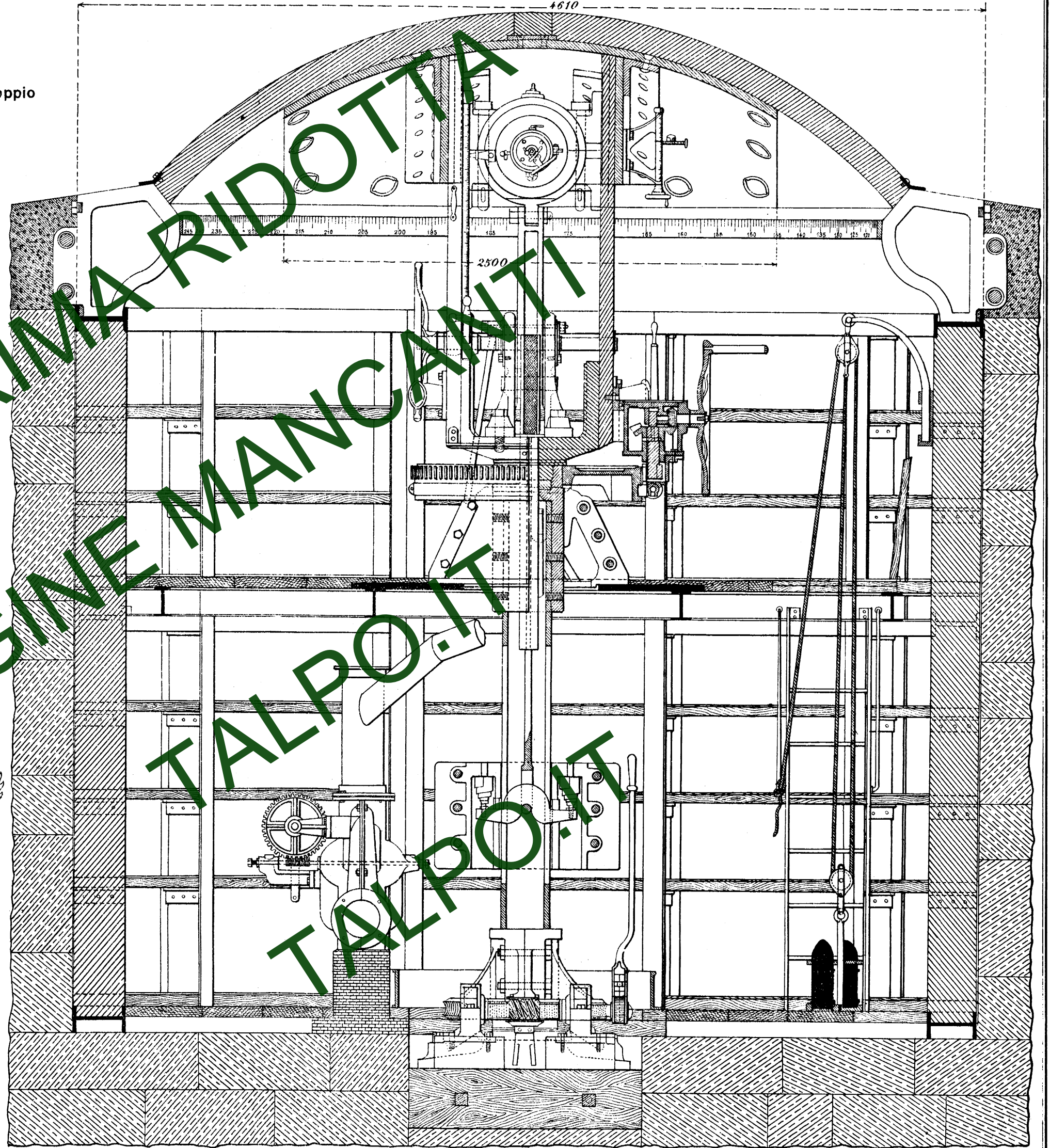

ANTEPRIMA RIDOTTA  
PAGINE MANCANTI  
TALPO.IT



INSTALLAZIONE PER CANNONE DA 149 A IN OPERA A POZZO TIPO ARMSTRONG (TIPO A)

Sezione verticale

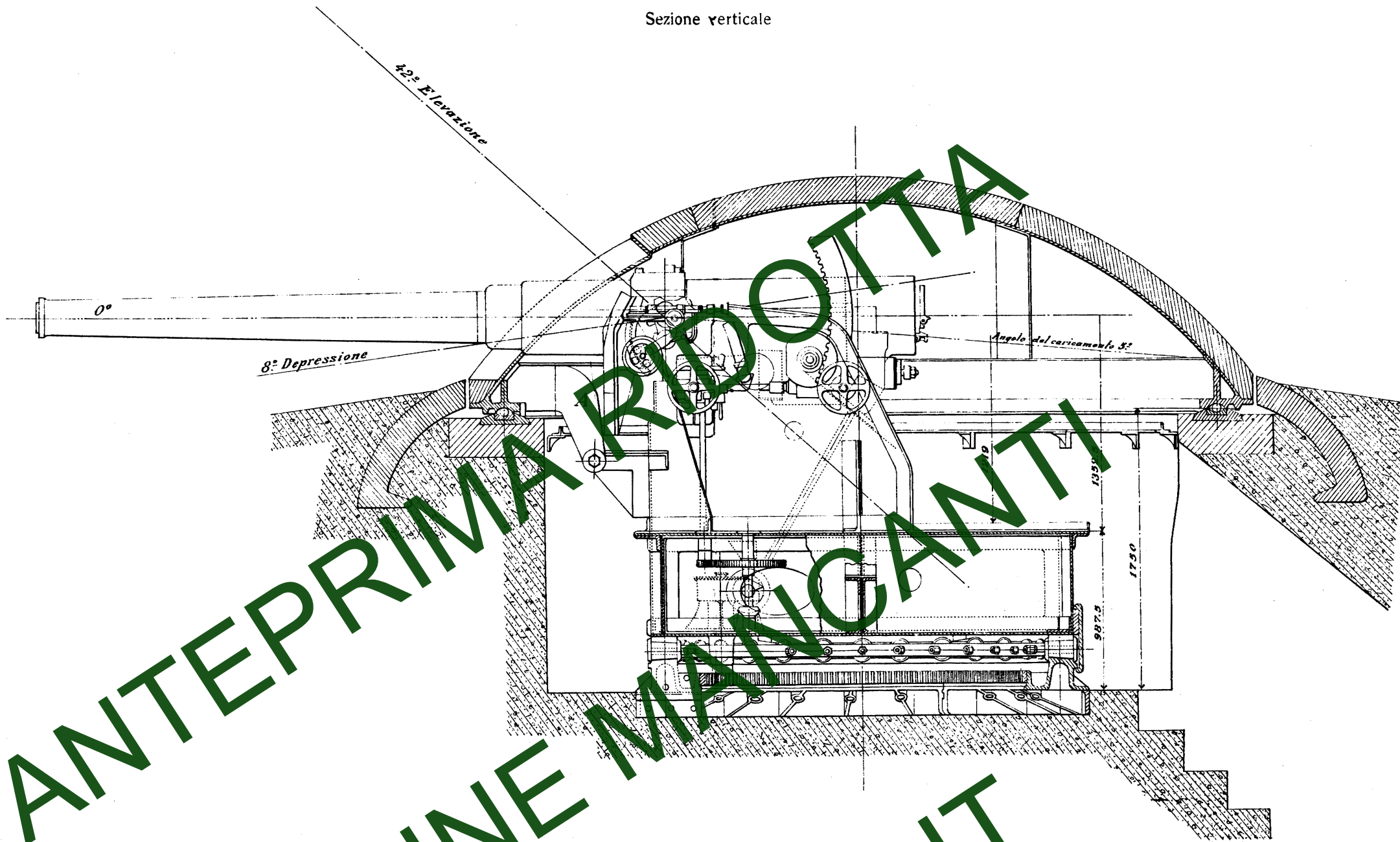

Pianta

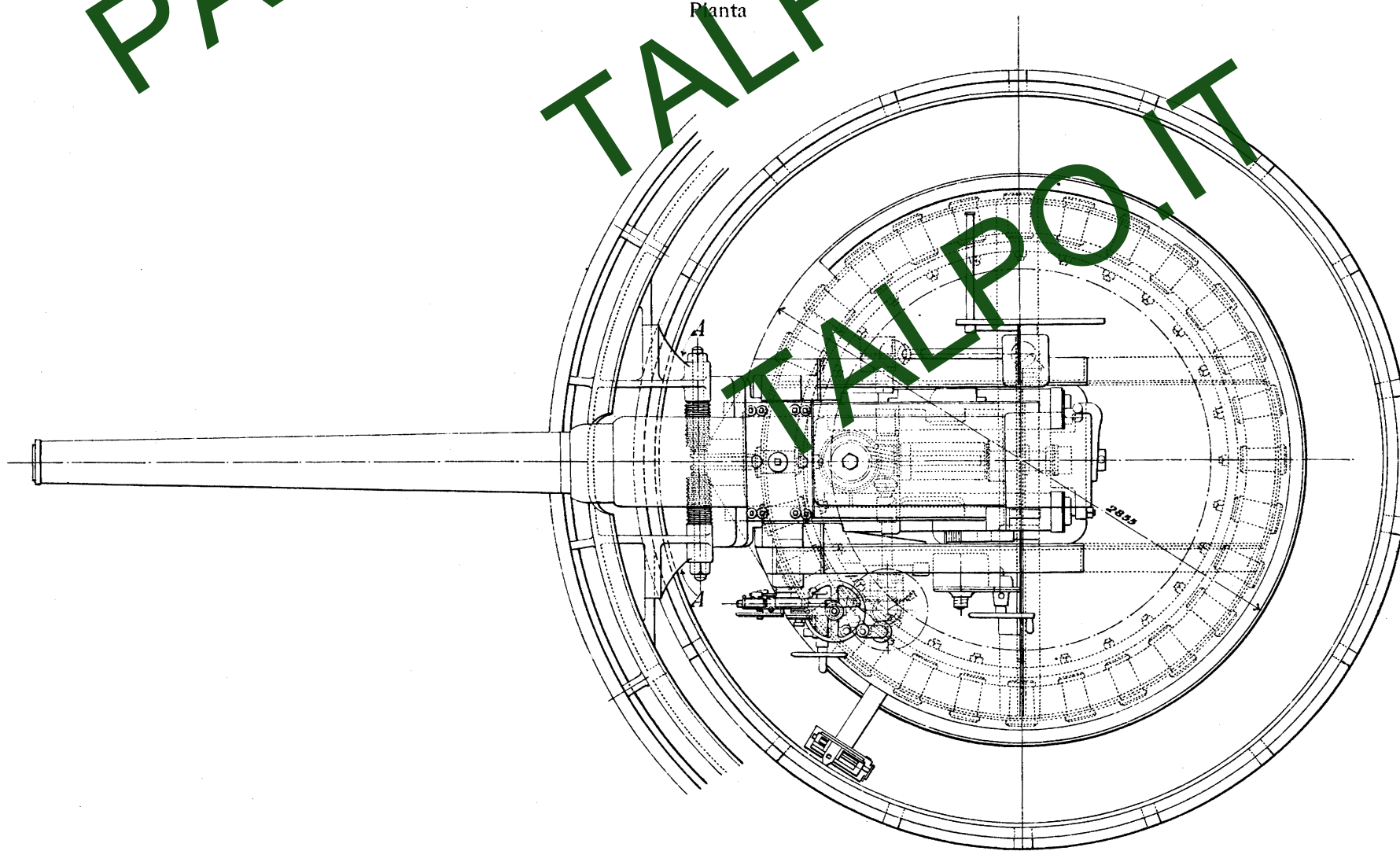



INSTALLAZIONE PER CANNONE DA 149 A TIPO ARMSTRONG (TIPO A)

Fig. 1

Freno del rinculo con pistone e pistoncino

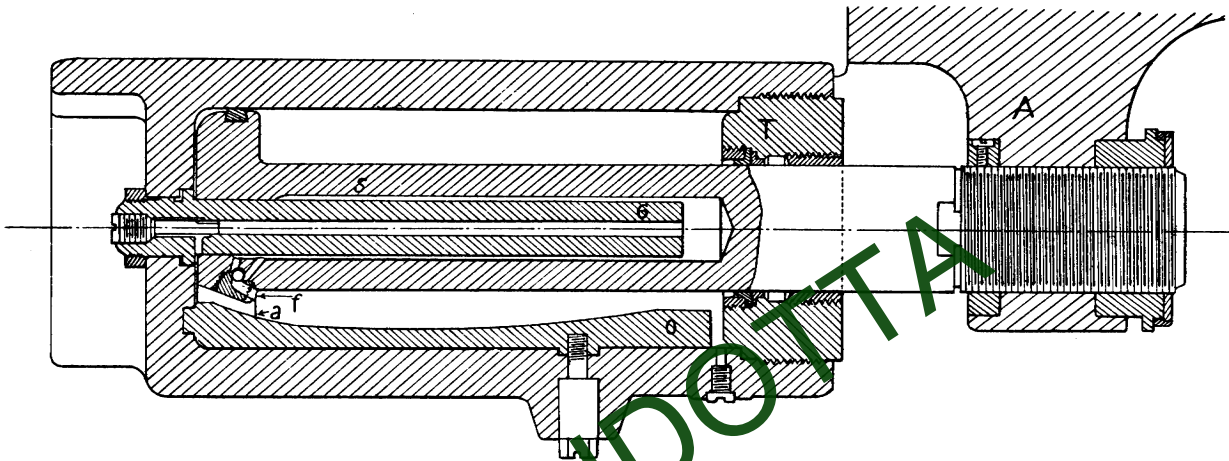
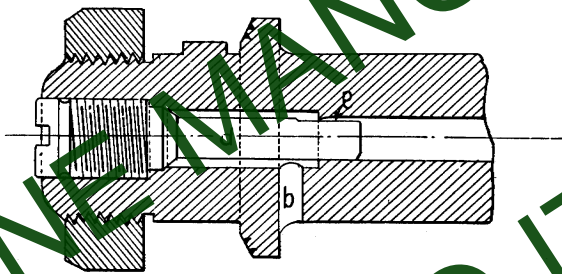
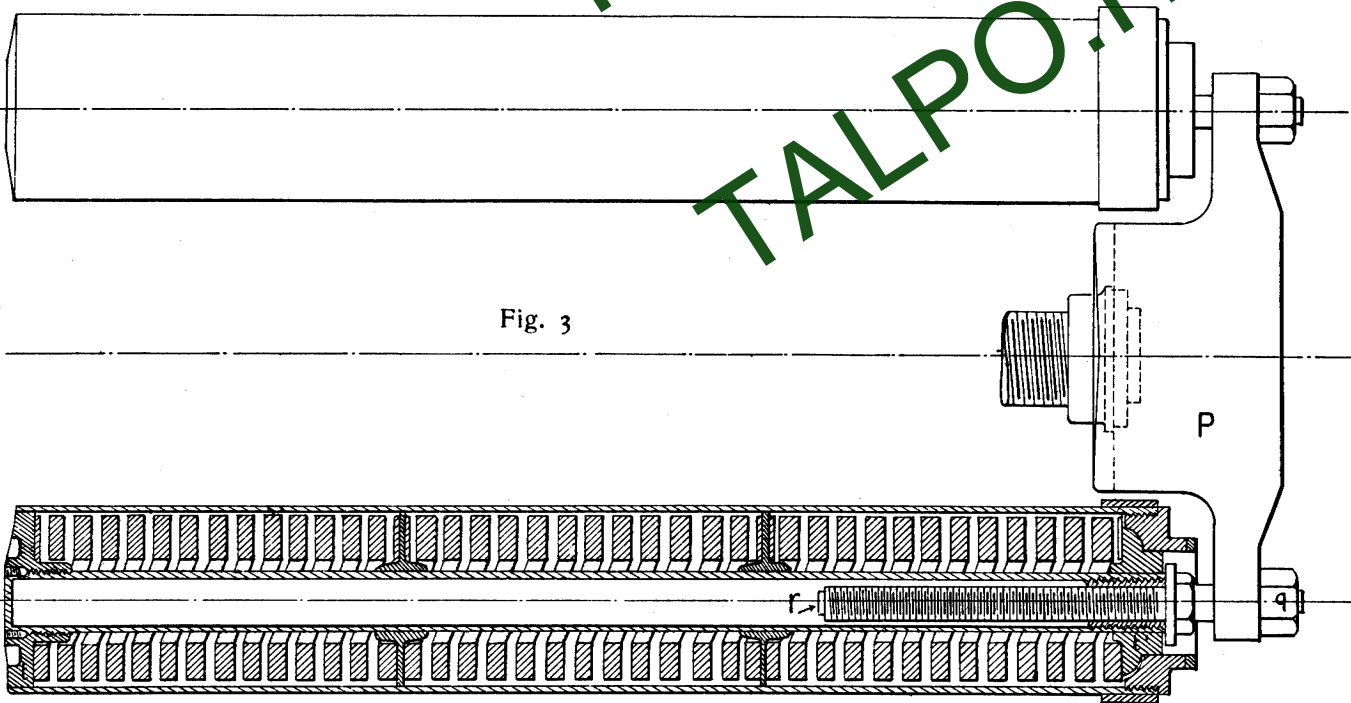

Fig. 2



Ricuperatori a molla

Fig. 3





INSTALLAZIONE PER CANNONE DA 149 A IN OPERA A POZZO TIPO ARMSTRONG (TIPO A)

Insieme del congegno di elevazione

Elevato  
Scala 1/10

Insieme dell'alzo

Vista posteriore verso P

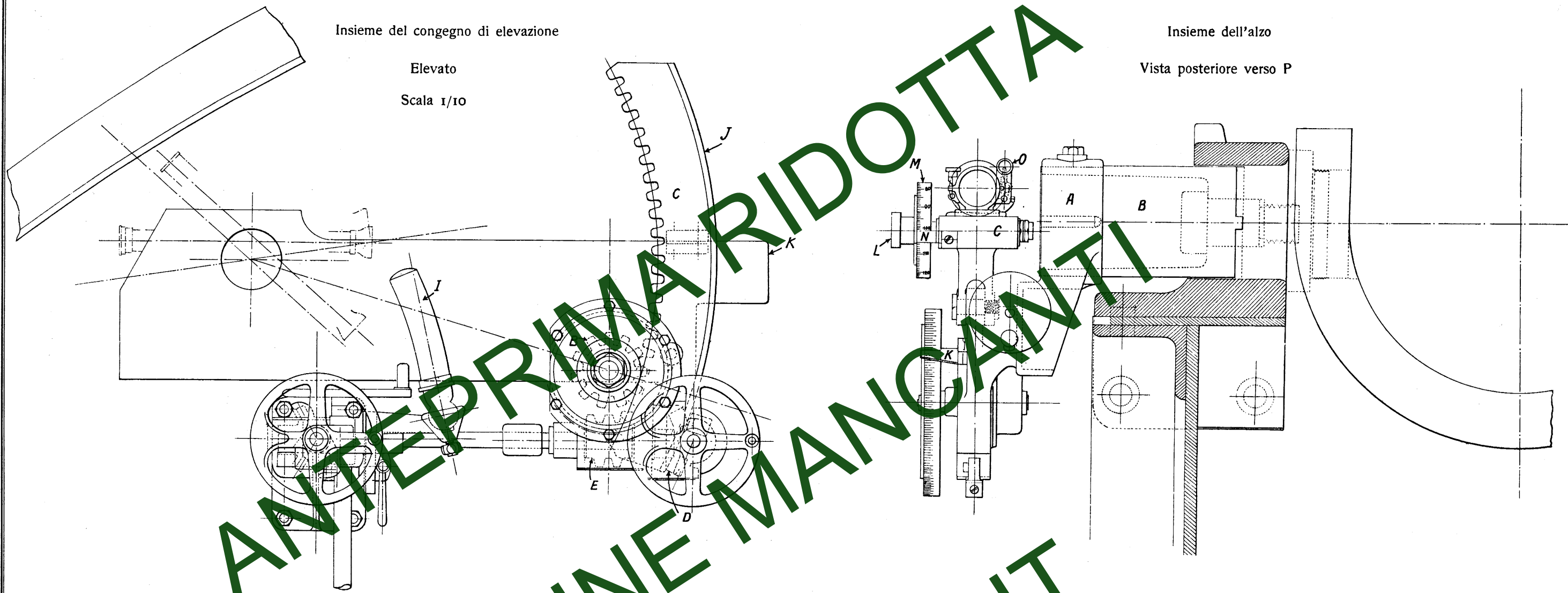

ASSE LONGITUDINALE DELLA INSTALLAZIONE

Planta

Visto in elevato

P ←

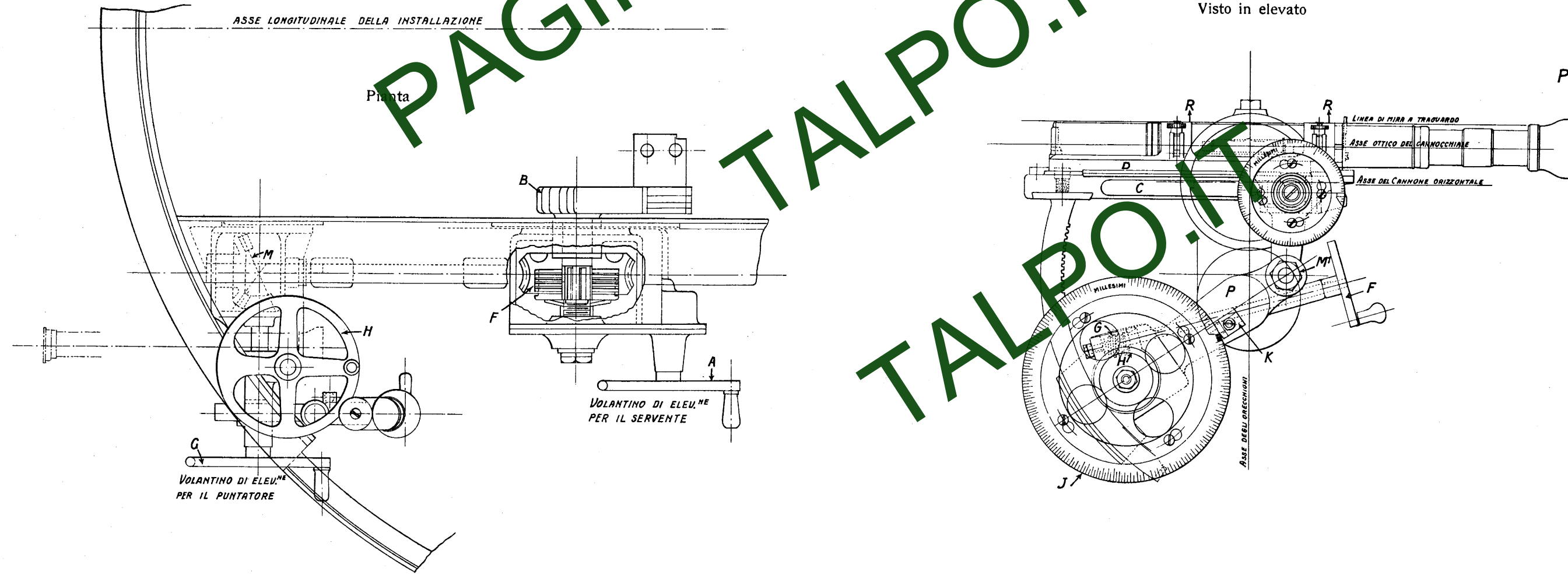

VOLANTINO DI ELEV. PER IL PUNTATORE

VOLANTINO DI ELEV. PER IL SERVENTE

ANTEPRIMA RIDOTTA  
PAGINE MANGANTI  
TALPO.IT

INSTALLAZIONE ALPINA DA 149 A (TIPO A)

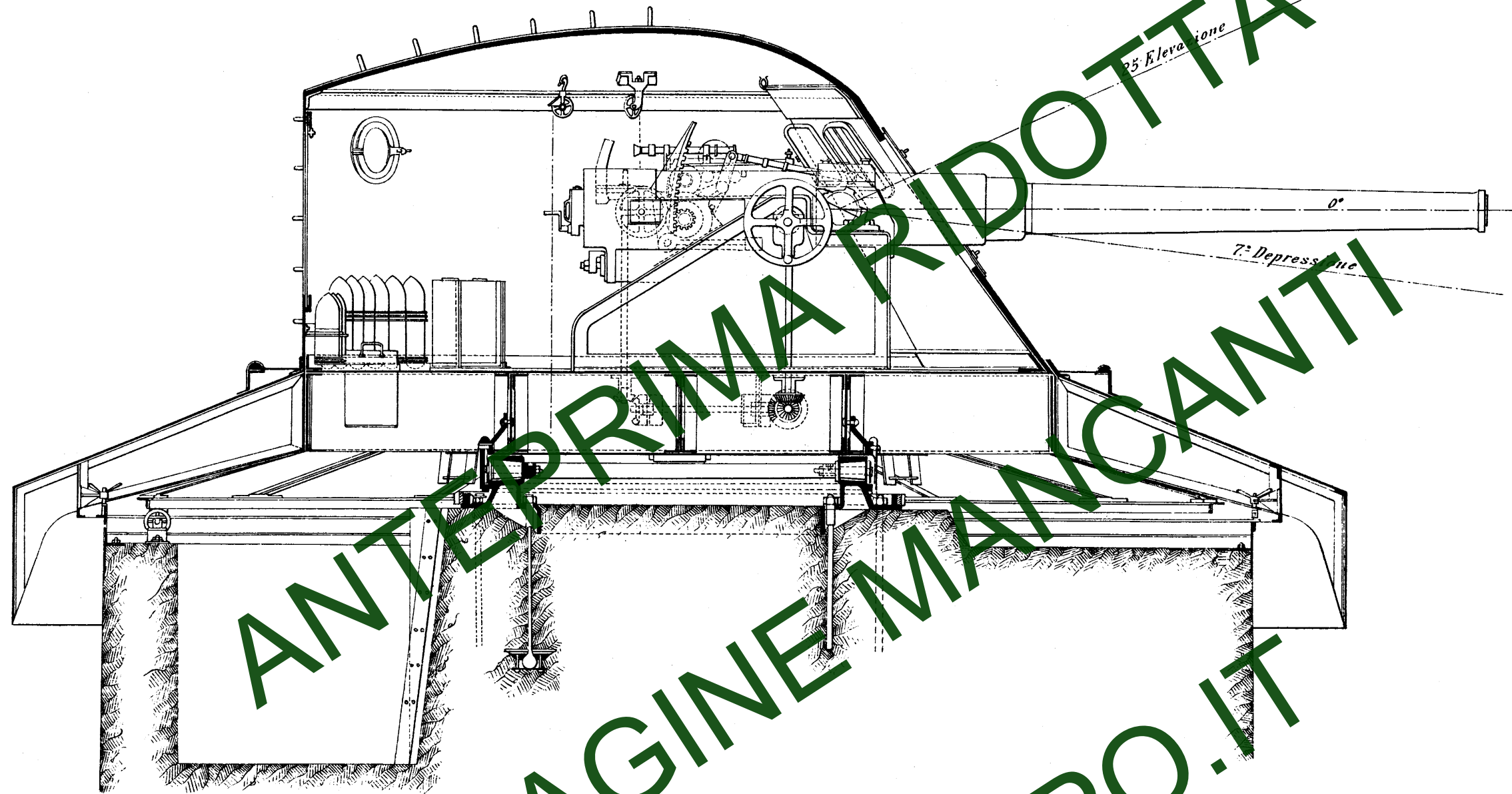

CONGEGNO DI DIREZIONE

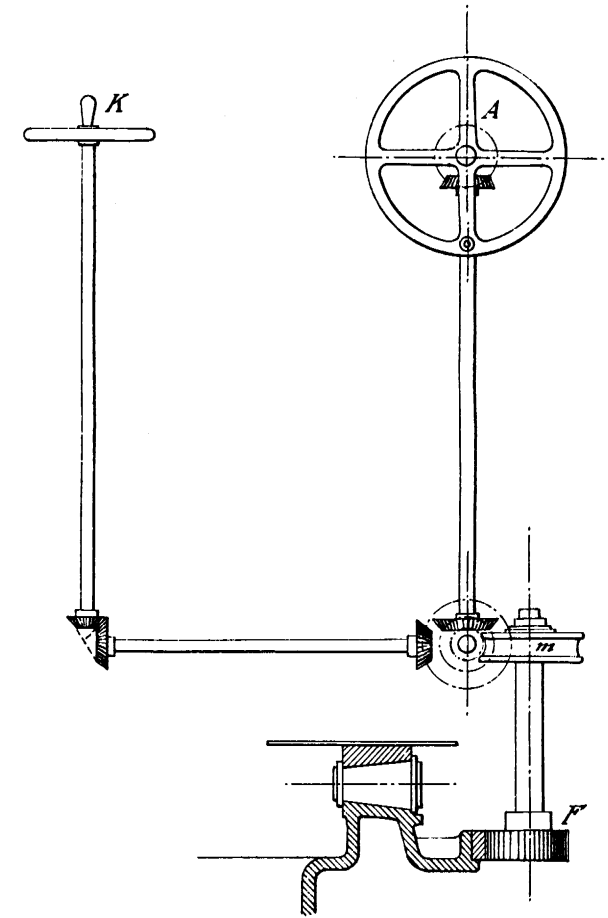

COLLEGAMENTO DEL CONGEGNO D'ALZO ALLA CULLA

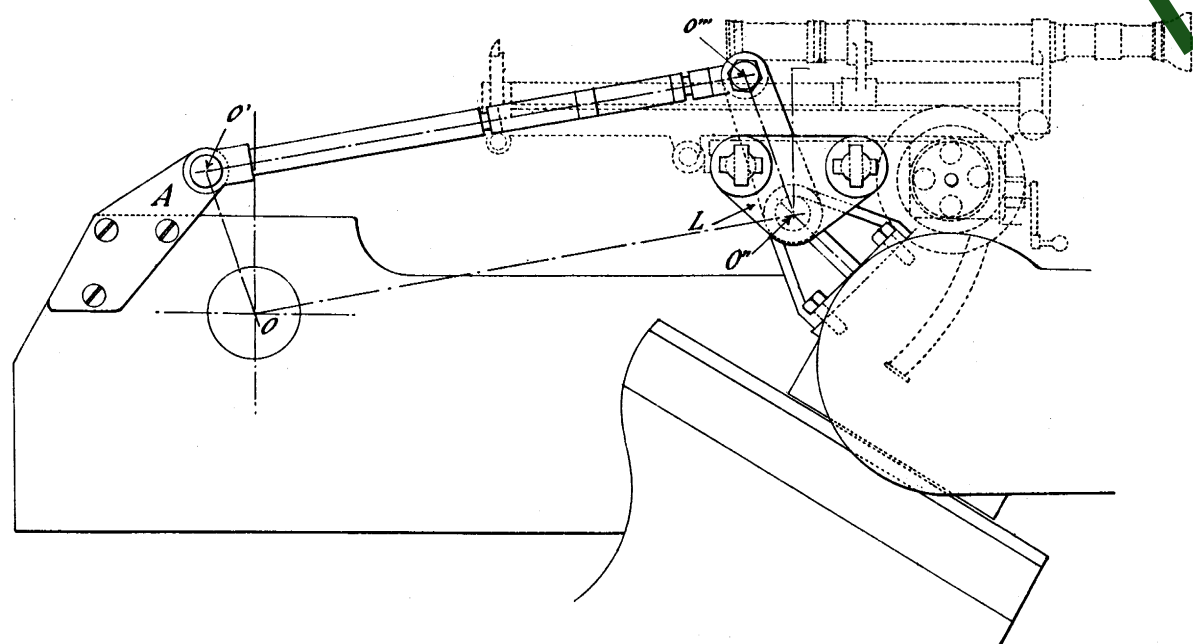

CONGEGNO DI FRIZIONE DEL SISTEMA DI ELEVAZIONE

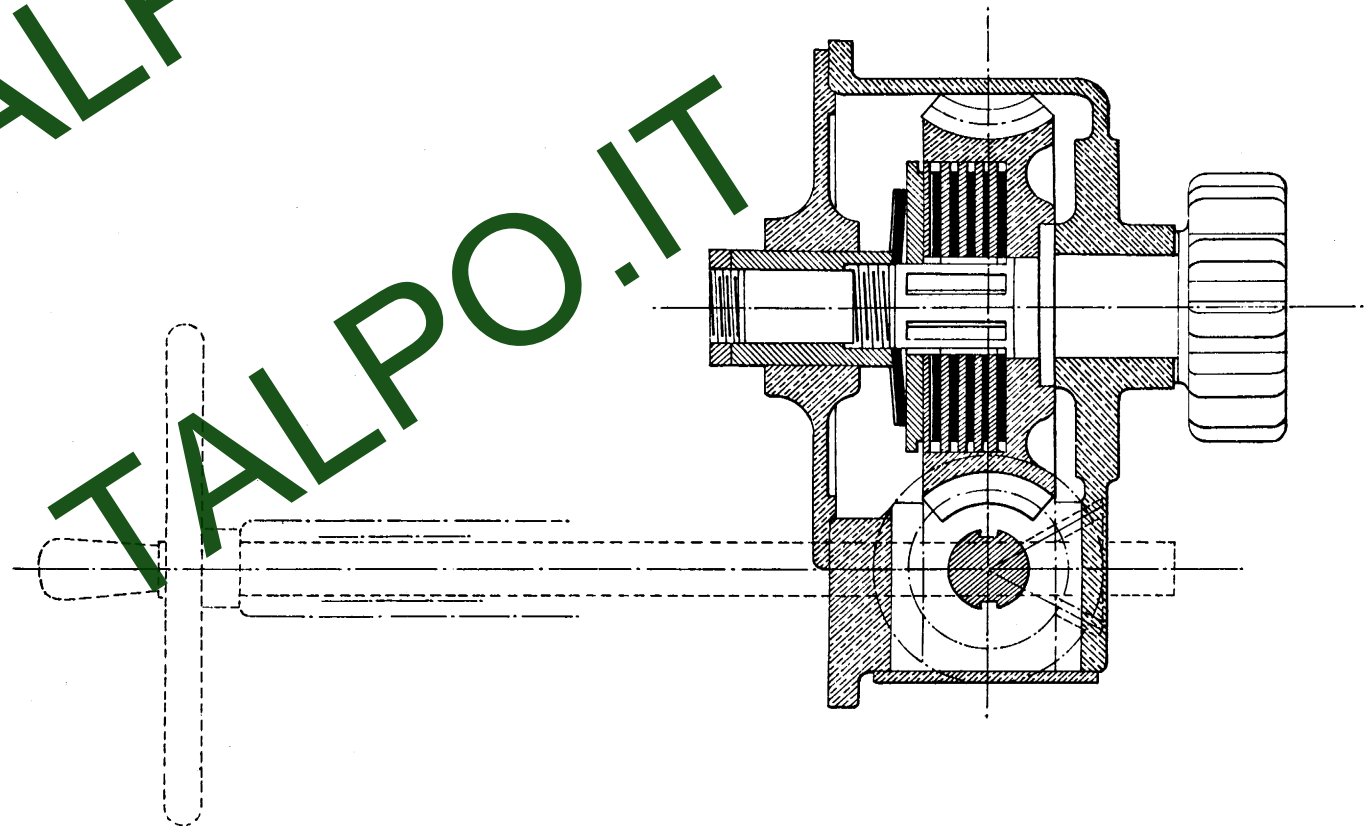



INSTALLAZIONE TIPO G. PER CANNONE DA 149 A.

Scala di 1:30

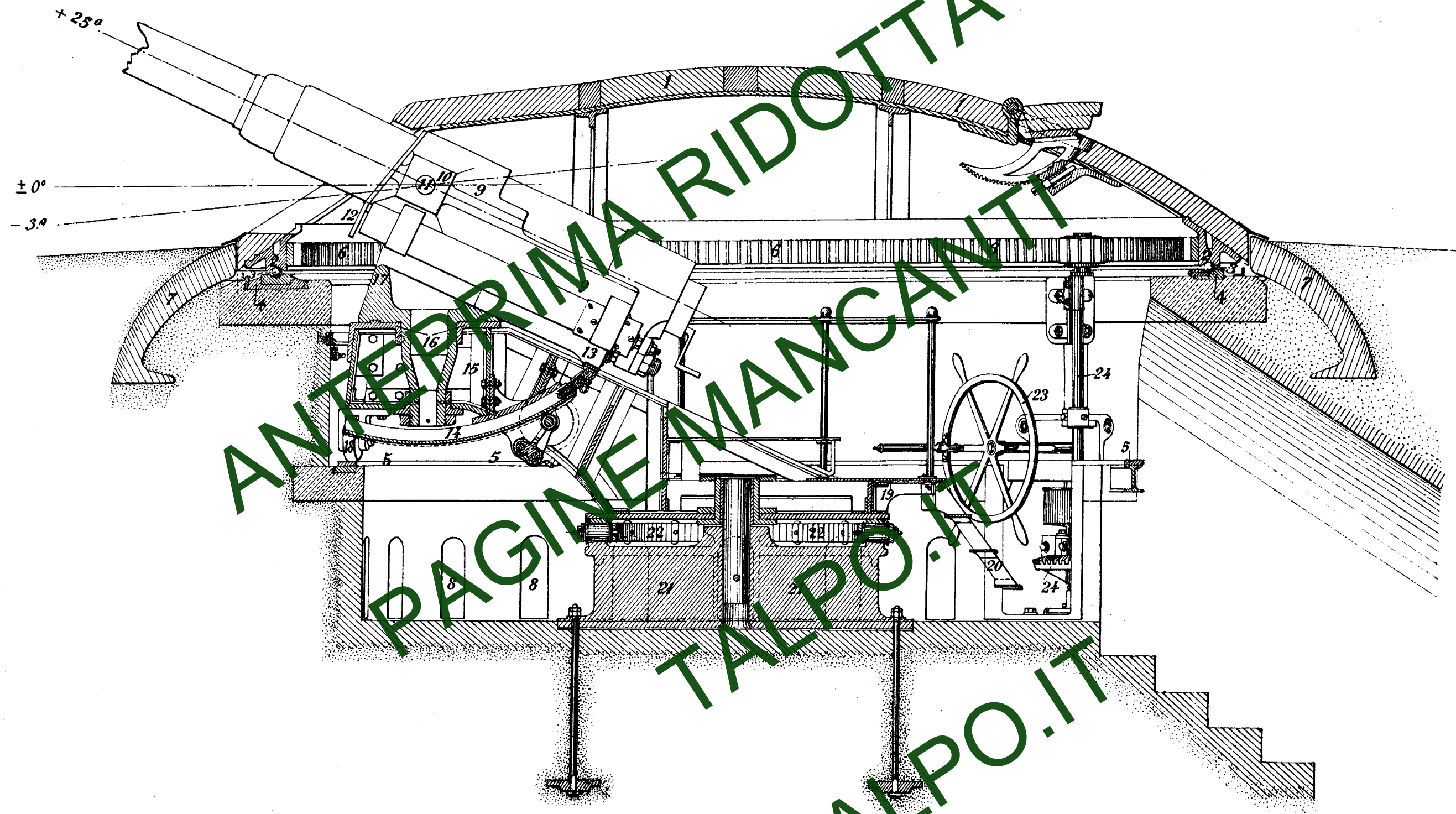

- 1) Copertura; 2) rotaia a gola; 3) sfere; 4) rotaia a gola; 5) rotaia di affusto; 6) corona dentata per il congegno di direzione; 7) avancorazza; 8) nicchie per munizioni; 9) culla; 10) zoccolo; 11) perno orecchione; 12) scudo; 13) cilindro del freno; 14) arco di elevazione; 15) affusto; 16) piastrone ad occhio; 17) affustino; 18) rotella d'affusto; 19) pedana di affusto; 20) scaletta a cerniera; 21) rocchio; 22) corona di rulli; 23) volantino di direzione di destra; 24) congegno di direzione.

INSTALLAZIONE TIPO I, PER CANNONE DA 120 G.

Scala di 1:30

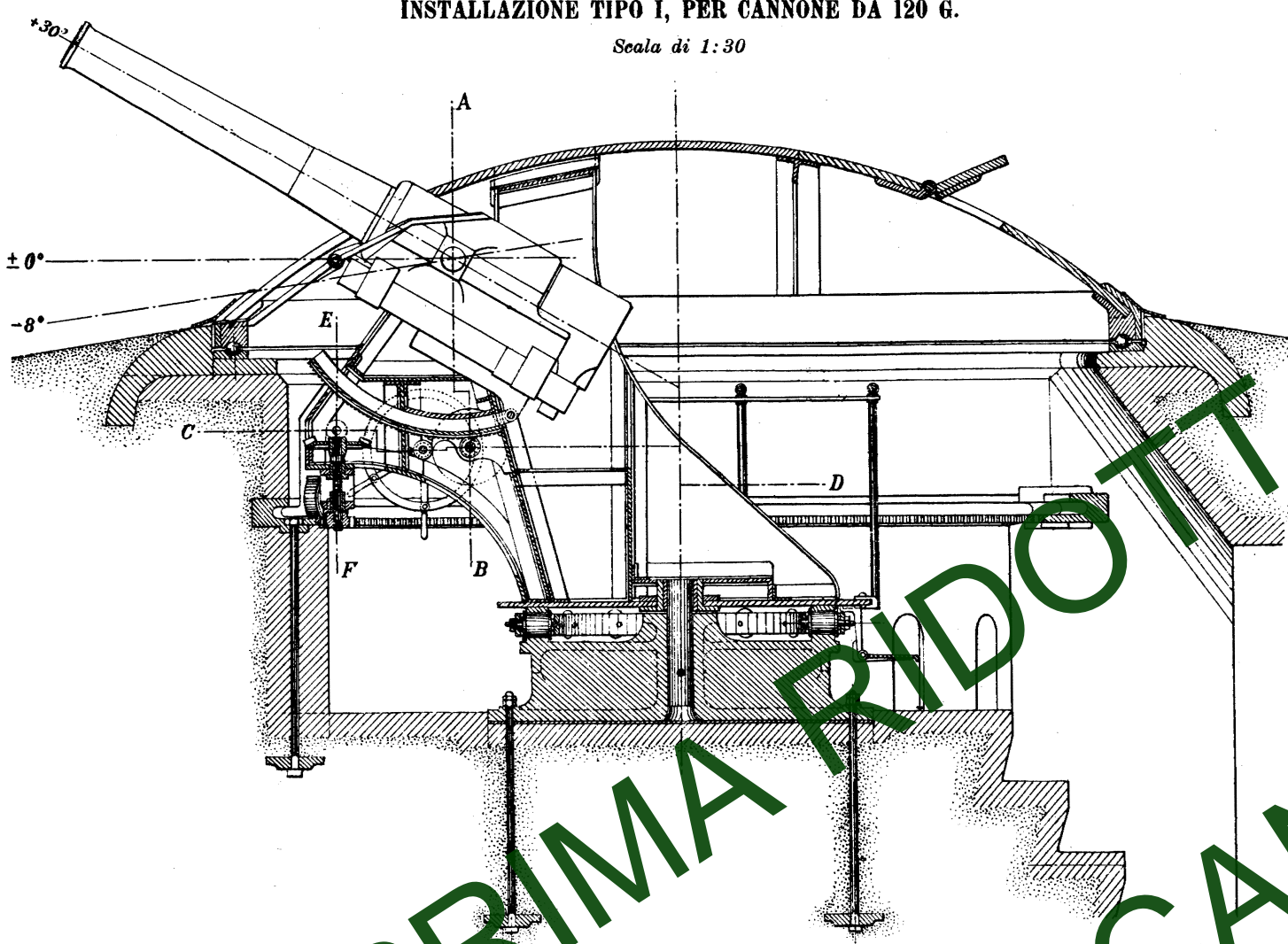

Sezione E F

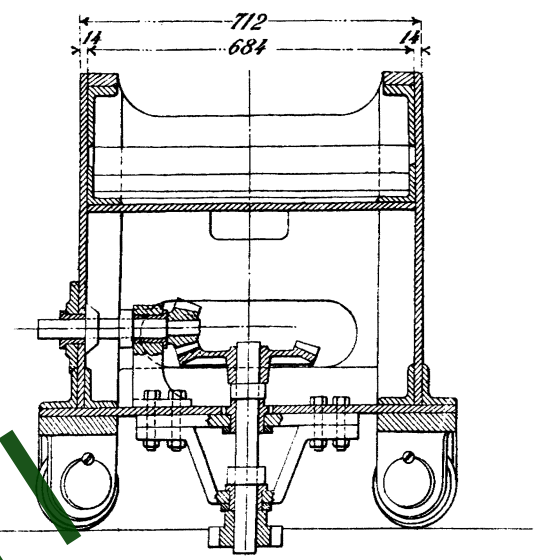

VISTA DI SOPRA SENZA SPULLA

Scala 1:30

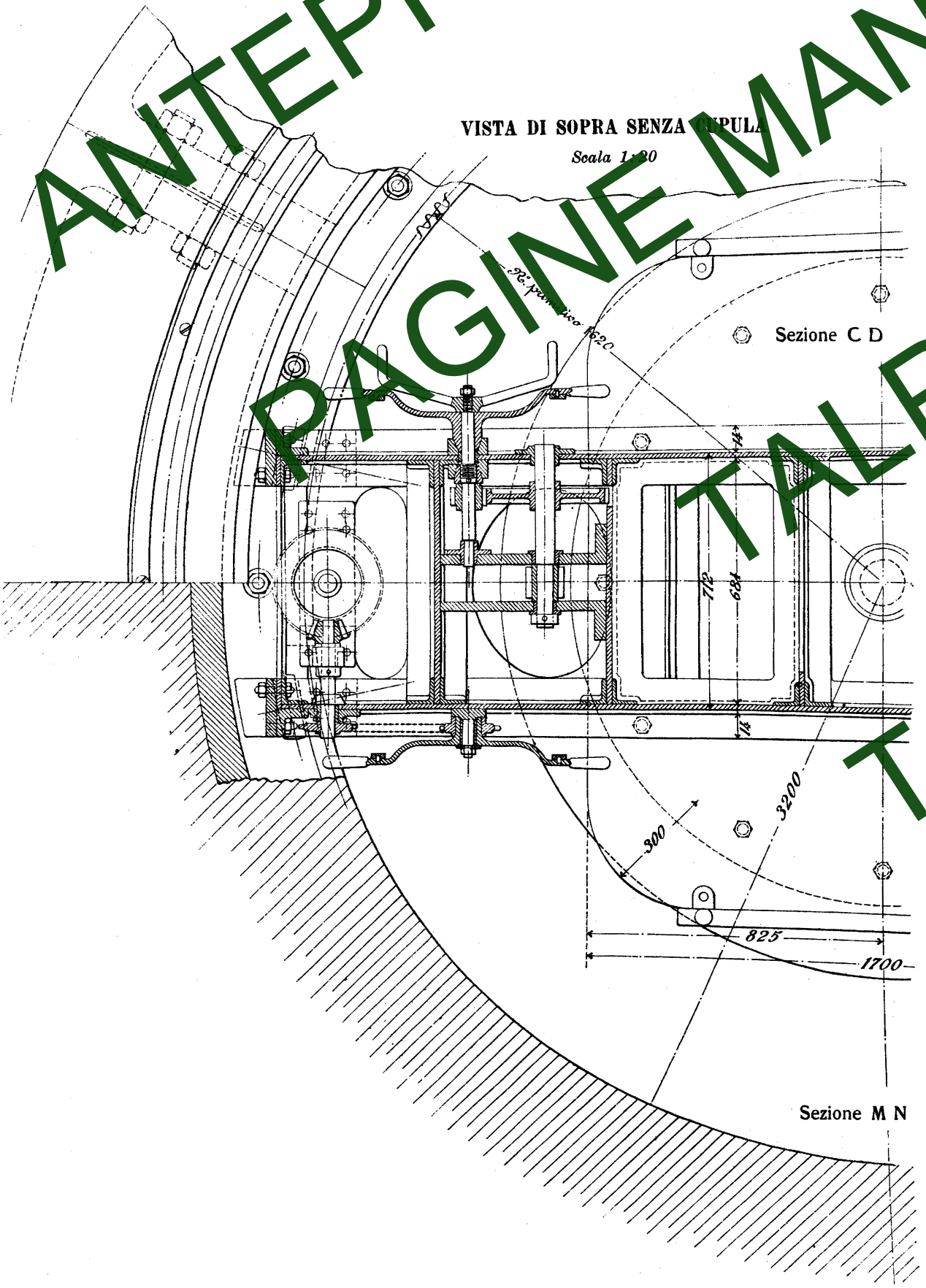

Sezione A B

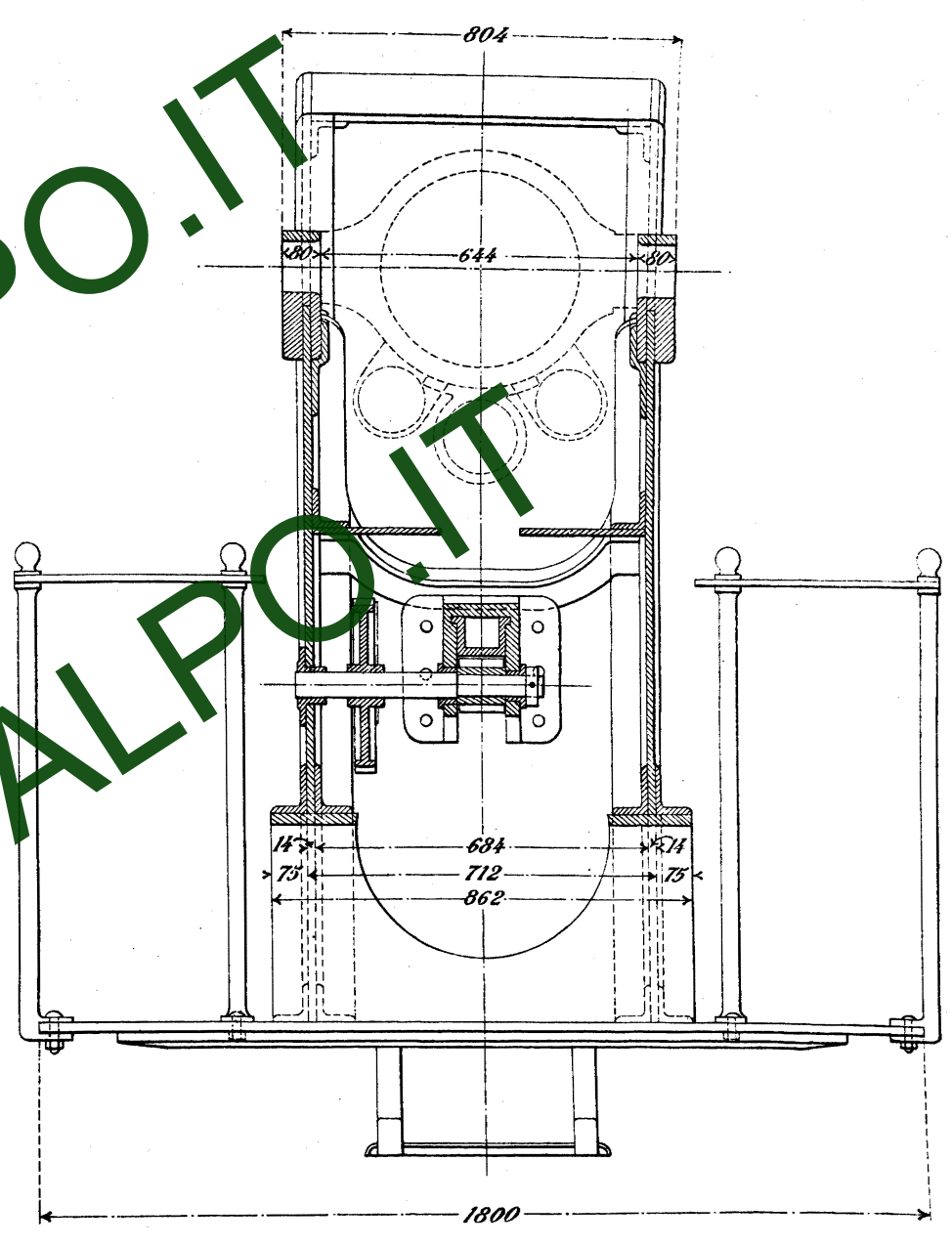

Sezione M N



INSTALLAZIONE TIPO I, PER CANNONE DA 149 G.

Scala di 1:30

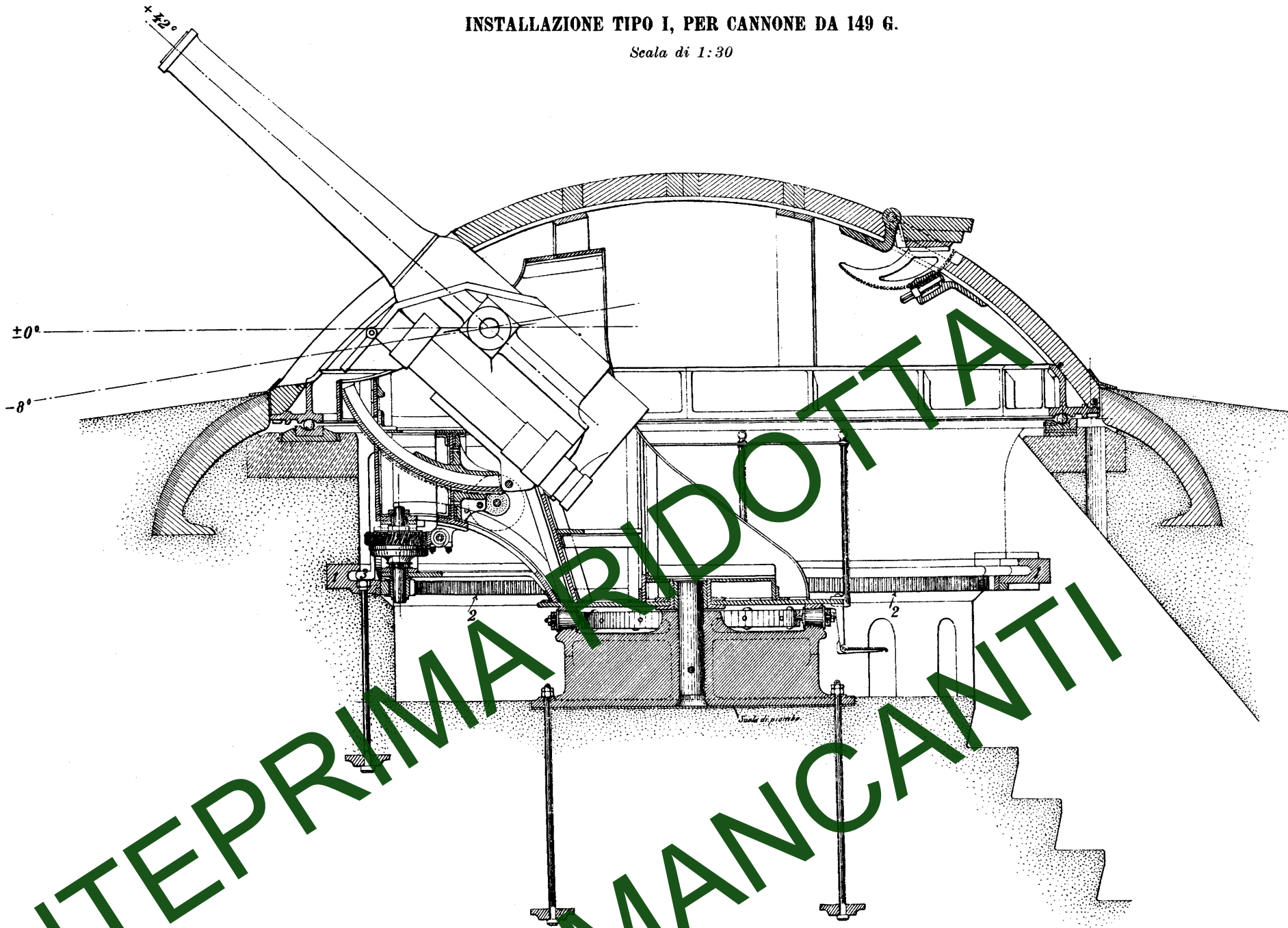

1) Rotala a gola; 2) corona dentata, per il cambio di direzione; 3) zampa ritenitiva della cassa di rotella d'affusto.

INSTALLAZIONE DA DIFESA CON COPERTURA PESANTE PER CANNONE DA 149 G. (Elevazione  $42^\circ$  e  $8^\circ$ )

Pianta (Scala 1:10)

Collegamento dell'affusto alla cupola.

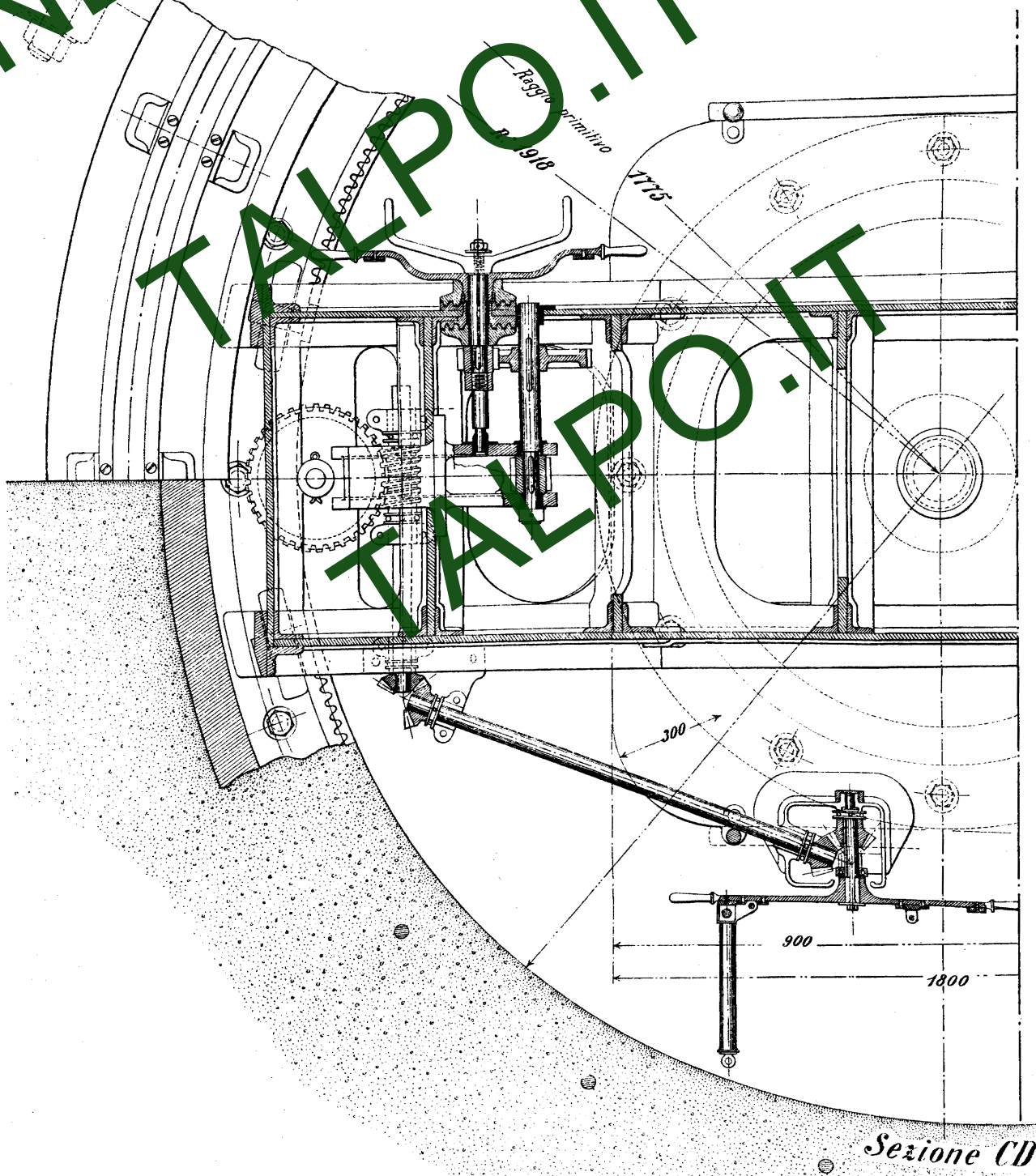
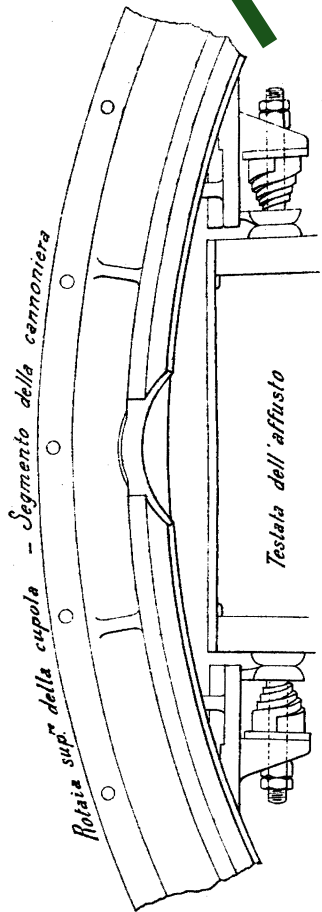



AFFUSTO PER CANNONE DA 254 B

FRENO IDRAULICO TIPO VAVASSEUR

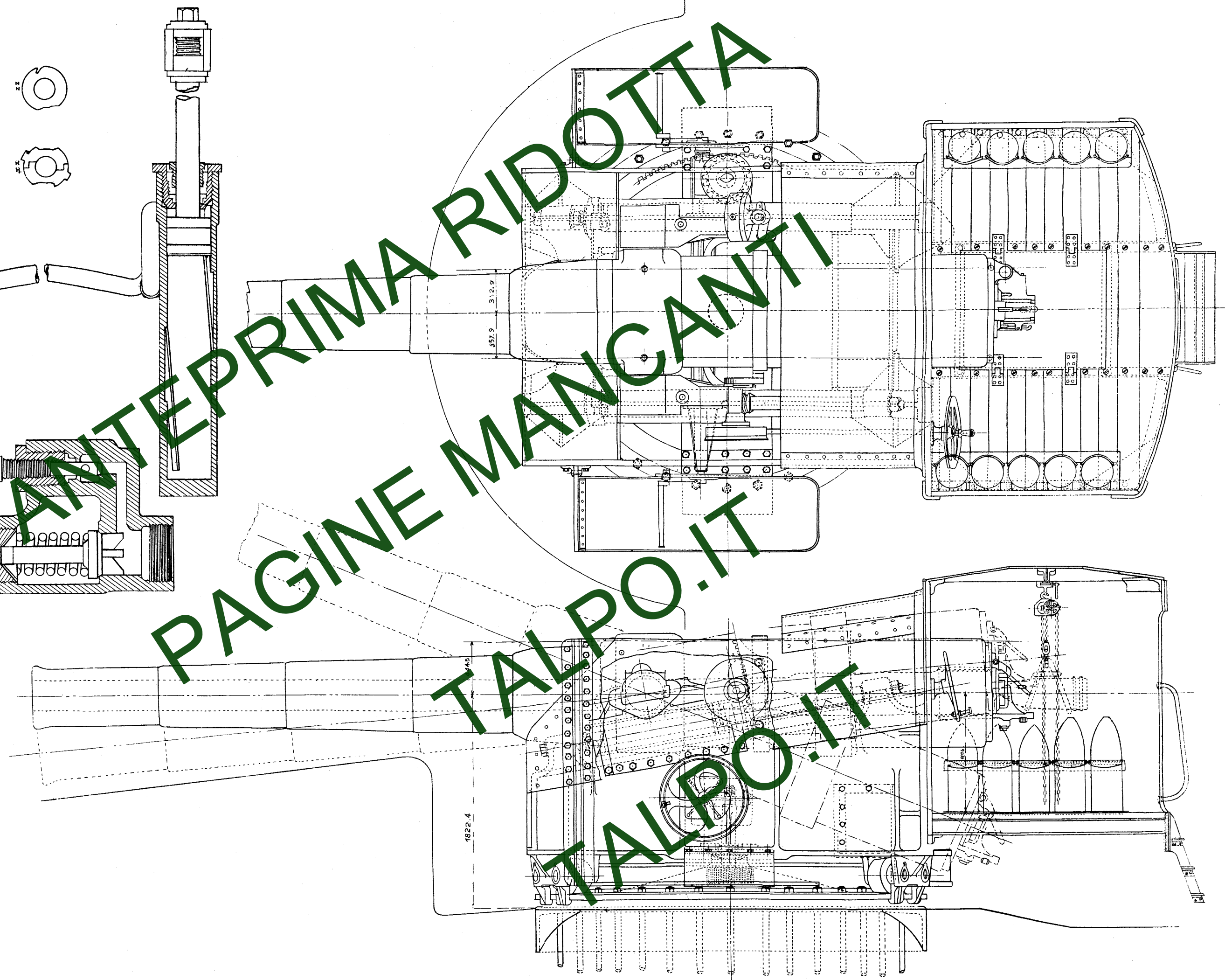
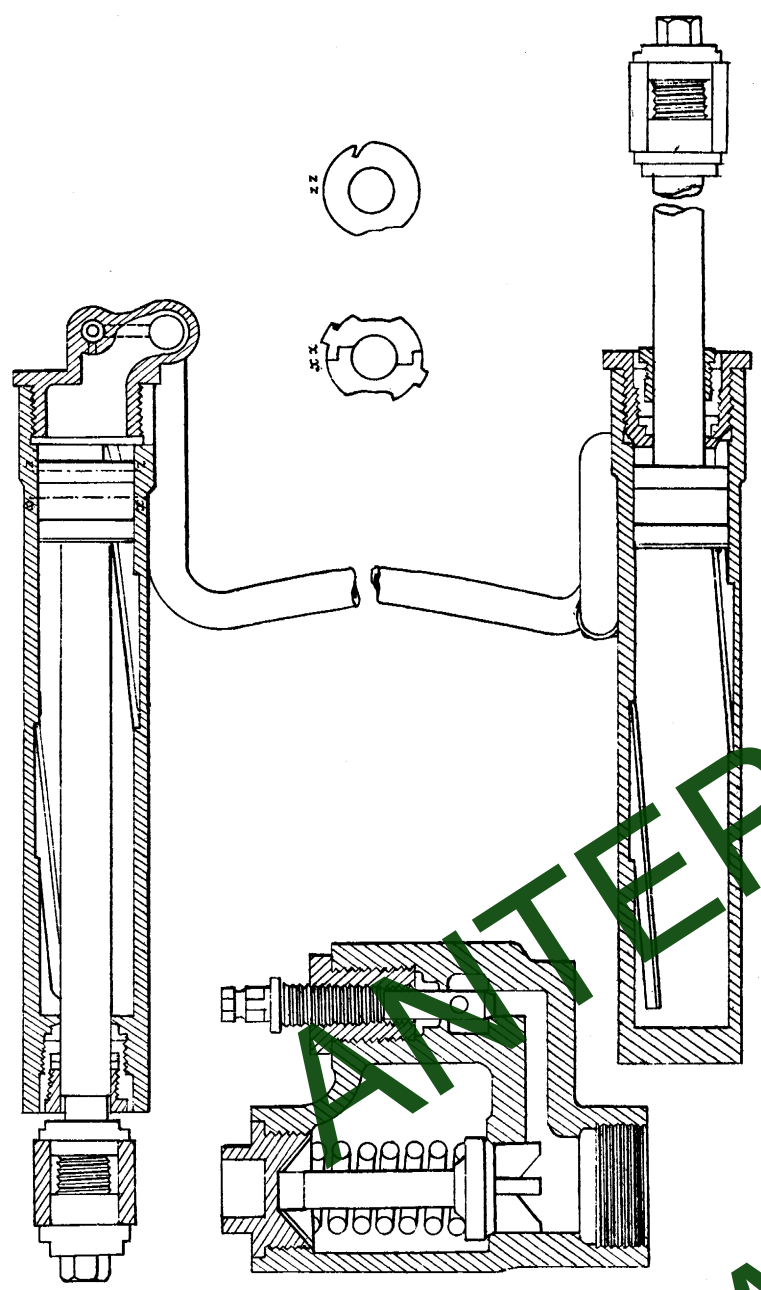



AFFUSTO A LISCE E FRENI LATERALI DA 152 B

Sezione longitudinale

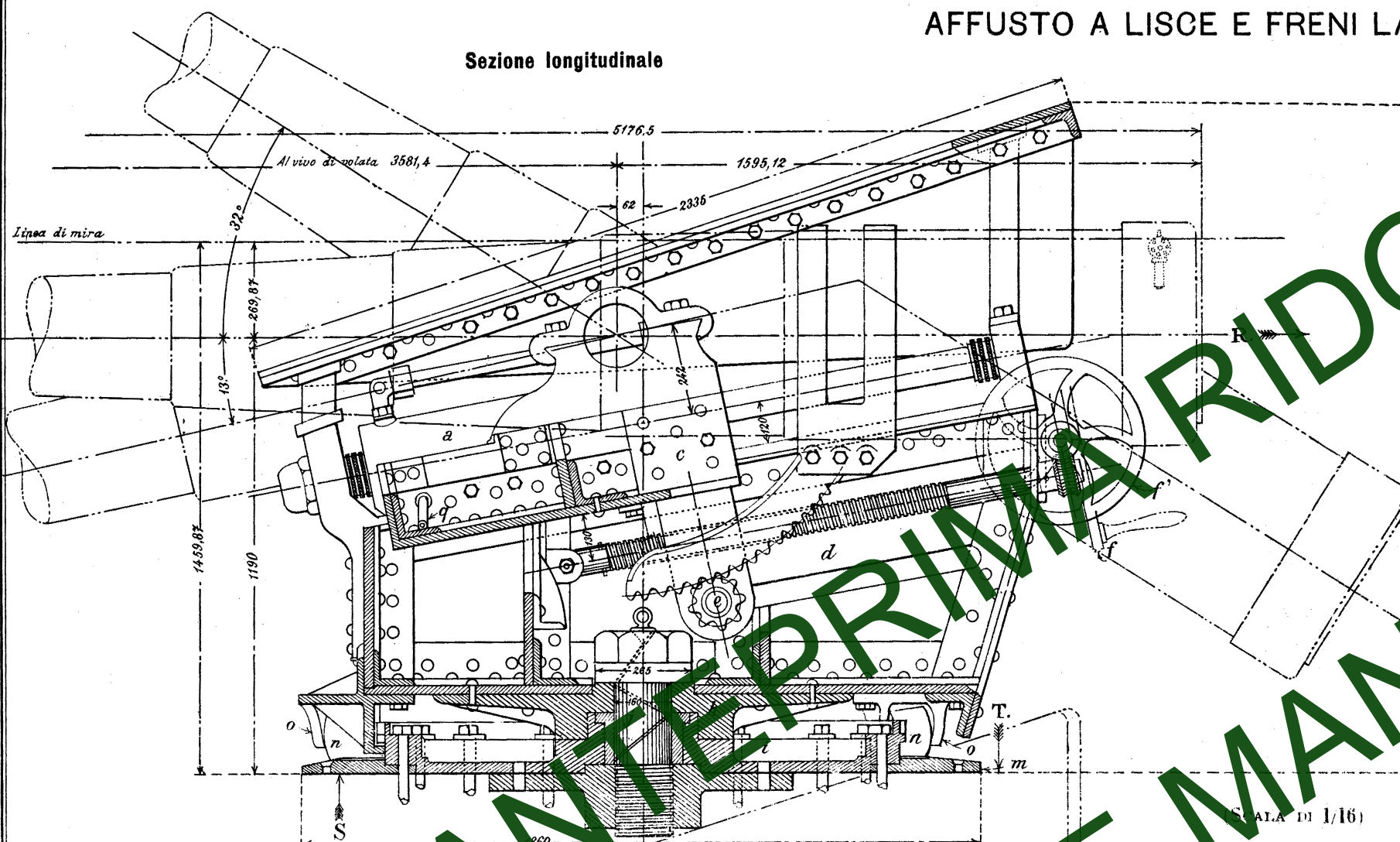

Vista posteriore

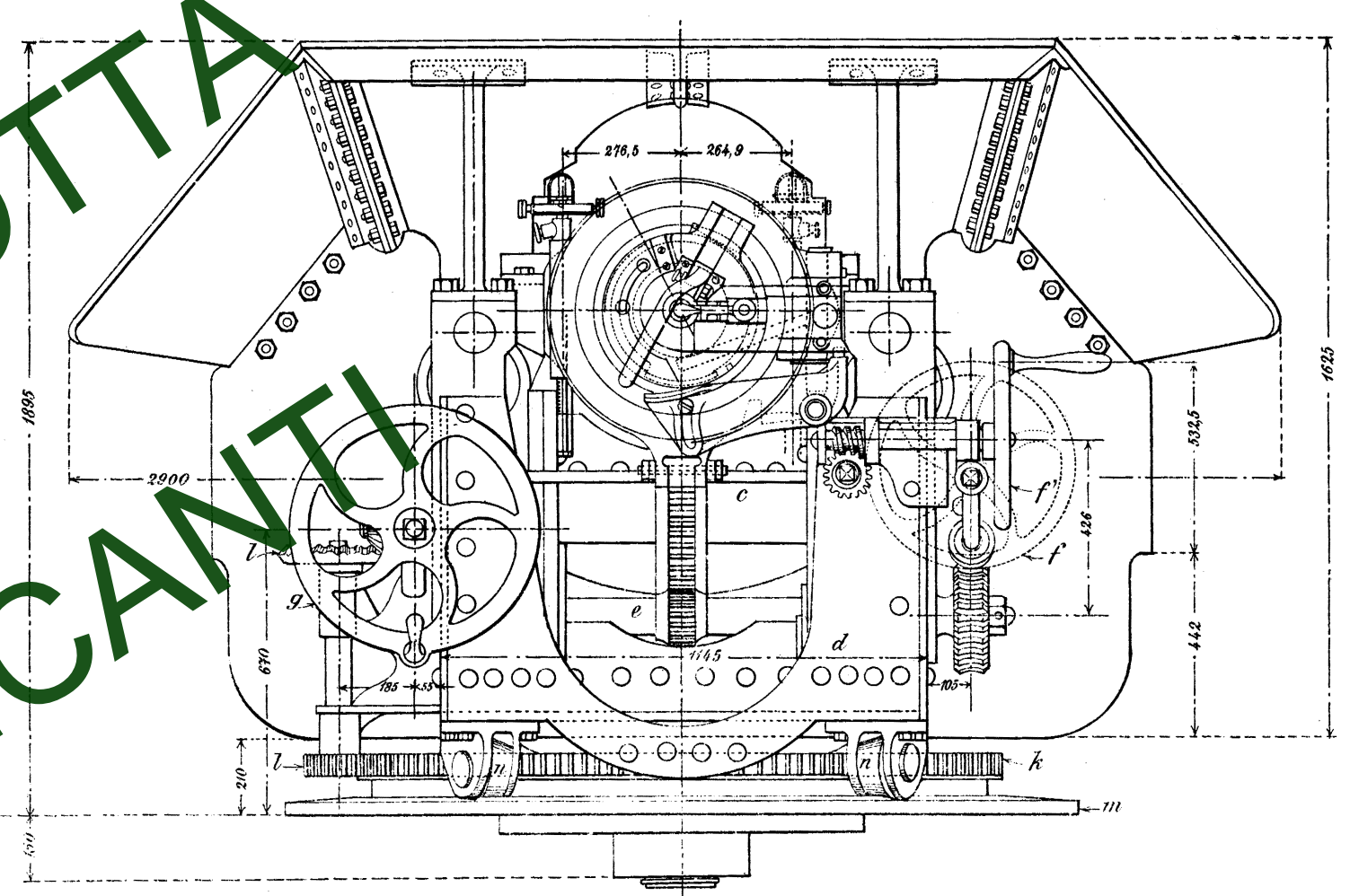

Vista di sopra (senza lo scudo)

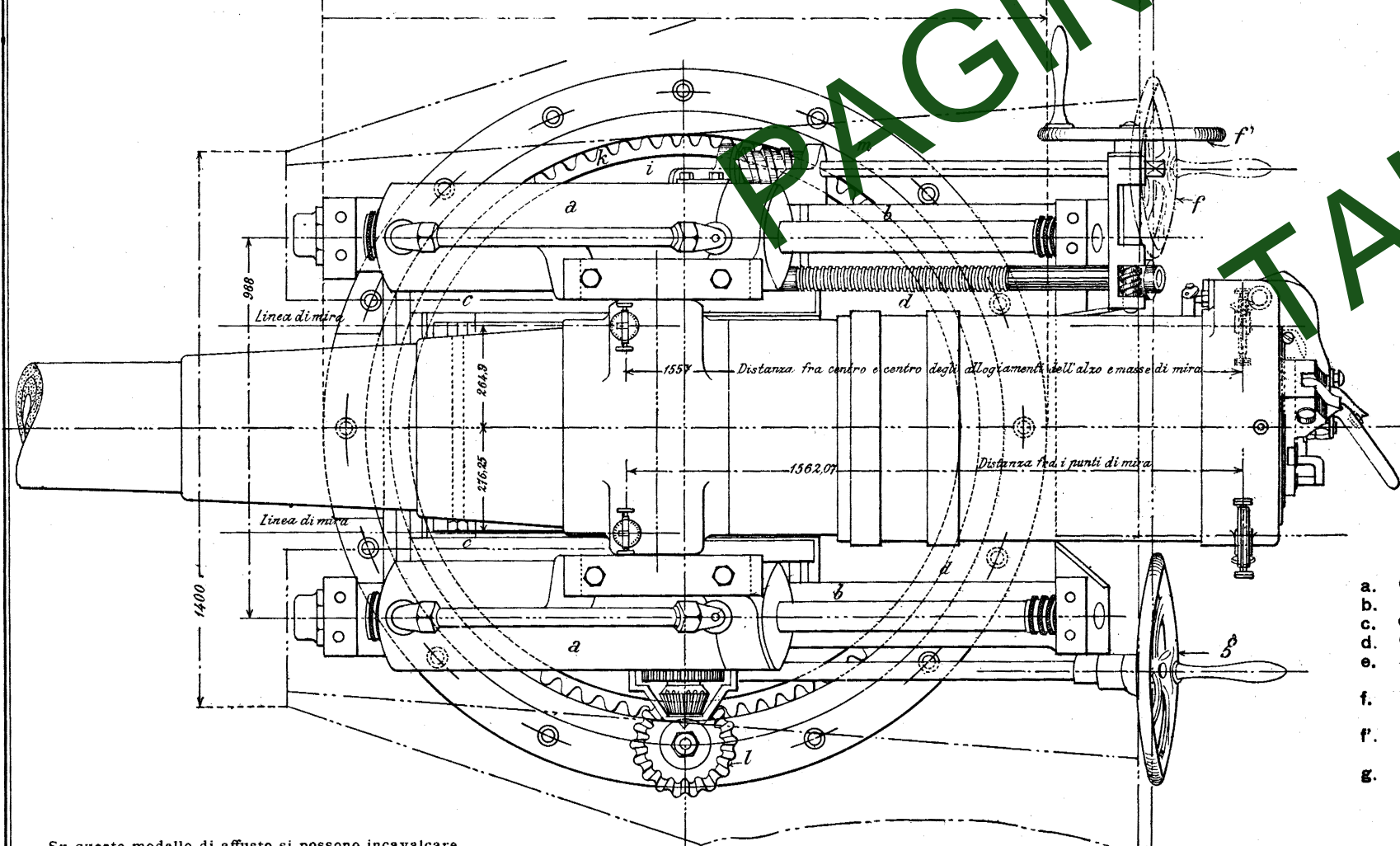

Sezione longitudinale del cilindro freno di sinistra

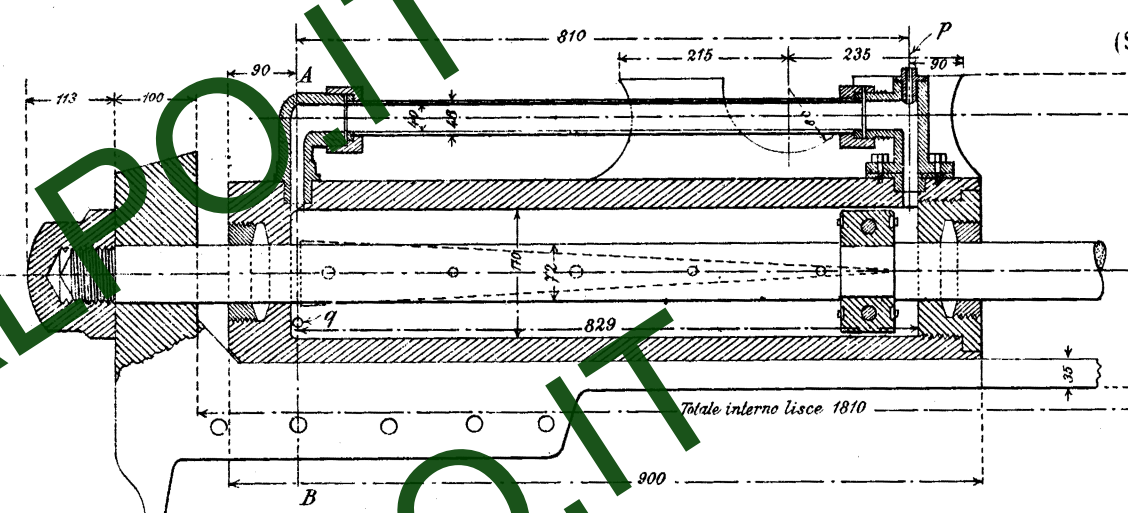

Sezione A B

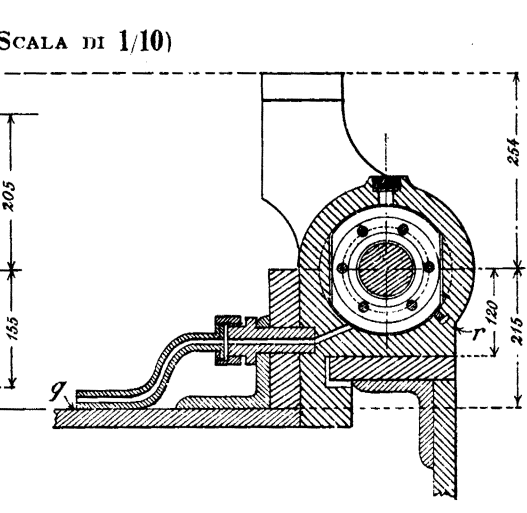

INDICAZIONI

- a. Cilindri freno di rinculo
- b. Lisce per il freno in batteria
- c. Calastrello d'entrata, collegato ai cilindri freno
- d. Cassone dell'affusto
- e. Asta orizzontale e rocchetto d'ingranaggio con la dentiera per la punteria verticale
- f. Volantino per la manovra del congegno di elevazione e depressione
- g. Volantino per il congegno di brandeggio
- h. Piattaforma girevole
- i. Piattaforma fissa
- k. Perno centrale di rotazione
- j. Corona dentata di brandeggio
- l. Rocchetti del congegno di brandeggio
- m. Rotella circolare d'appoggio dei rulli
- n. Rulli dell'affusto, scorrevoli sulla rotella
- o. Staffe dei rulli
- p. Foro d'immissione del liquido
- q. Tubo di comunicazione fra i due cilindri
- r. Foro di scarico

Inclinazione delle lisce	10°
Lunghezza libera per il rinculo	mm. 700
R. Sforzo di rinculo	Kg. 20137
S. Sforzo di strappamento	• 22500
T. Sforzo di compressione	• 23660
Quantità di liquido contenuto nei cilindri	litri 28,500

DATI DI PESO

Affusto completo, compreso la piattaforma fissa	Kg. 6190
Scudo	• 2250
Cannone completo	• 5680
Peso totale	Kg. 14060

Il volantino f del congegno di mandata in batteria e rientramento serve anche per il congegno di elevazione e depressione.

Su questo modello di affusto si possono incavalcare indifferentemente anche i cannoni da 152 C.



AFFUSTO A LISCE E FRENI LATERALI DA 152 C

Vista del lato destro

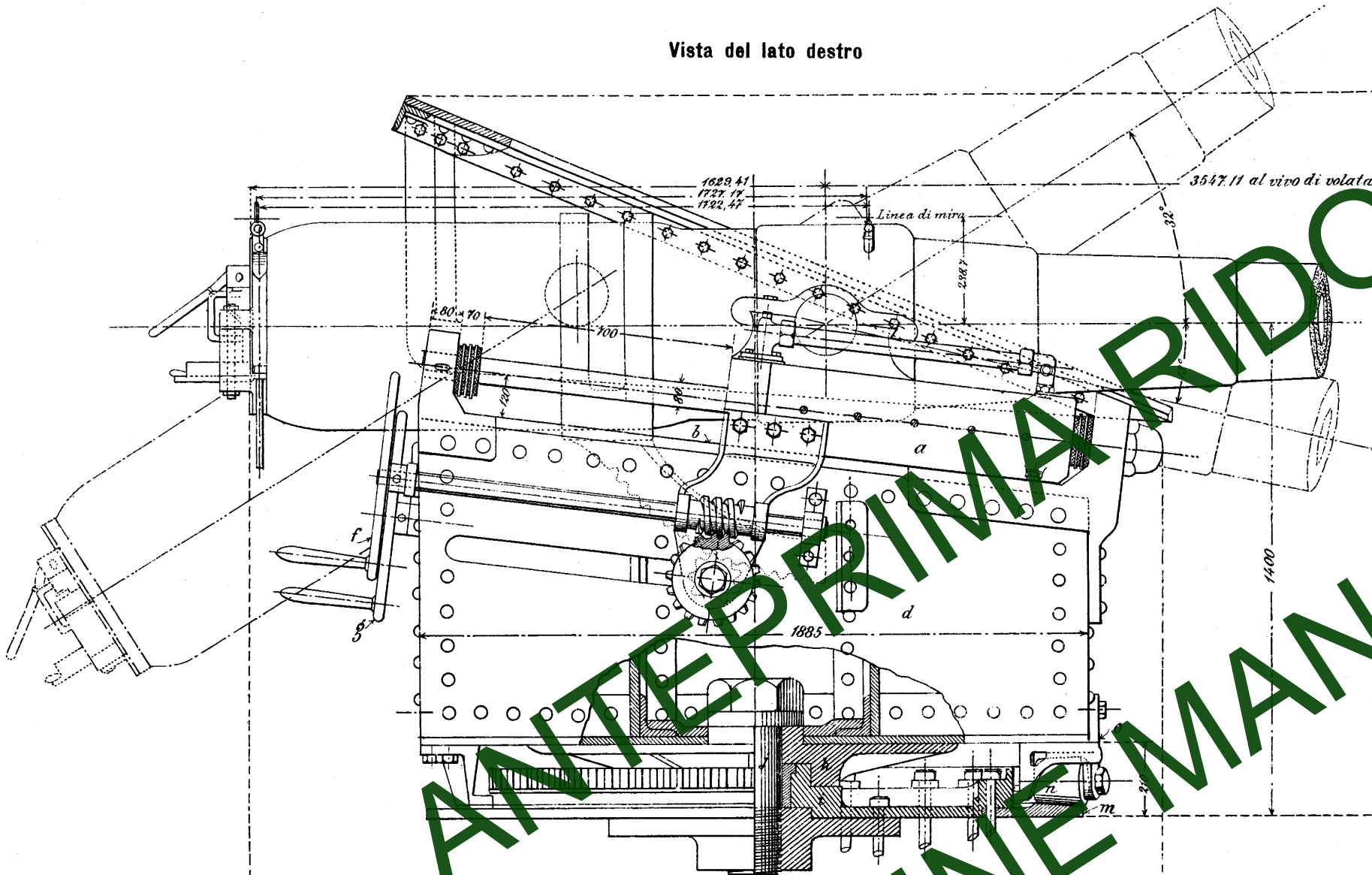

Vista posteriore

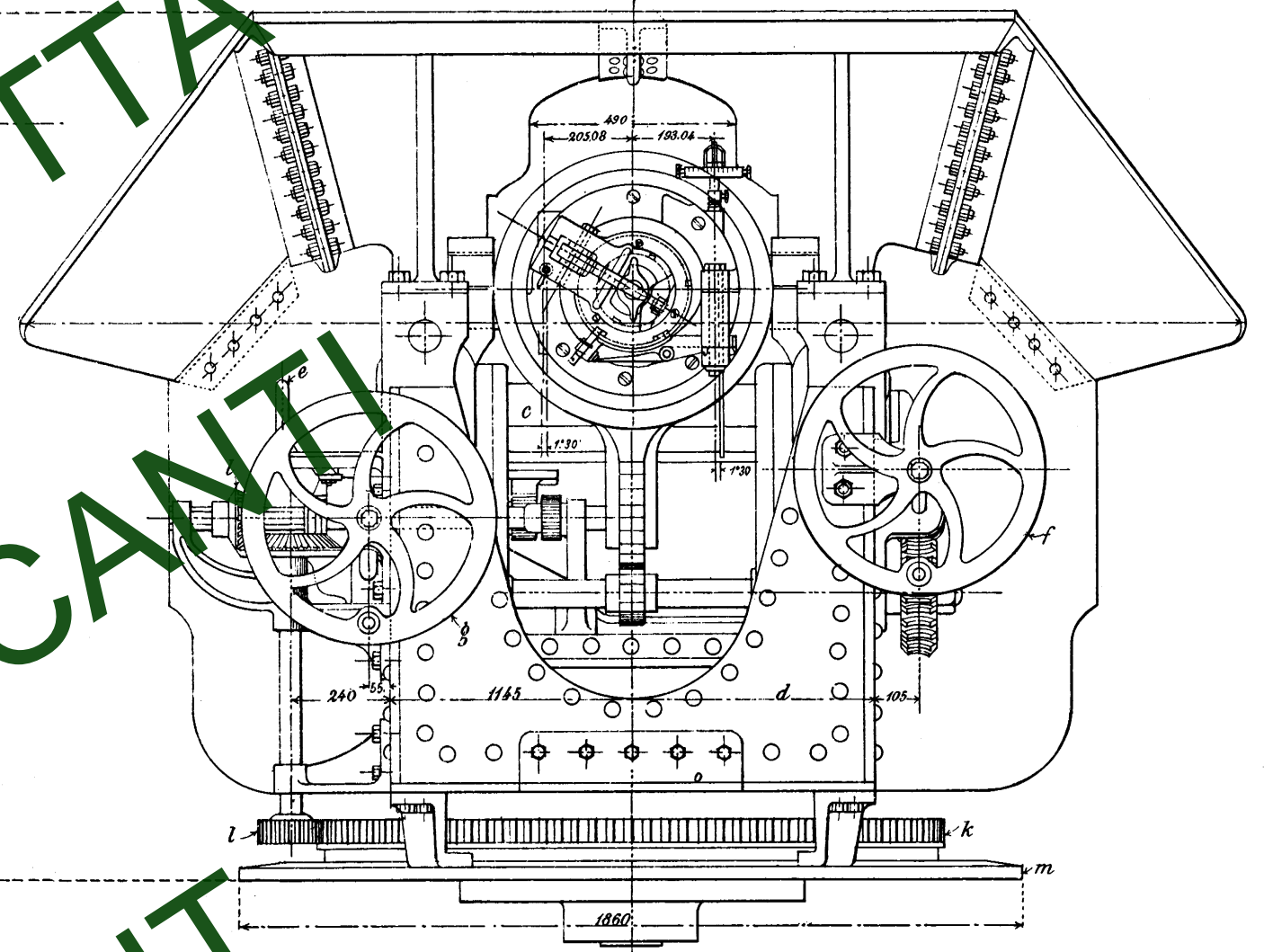

Vista di sopra

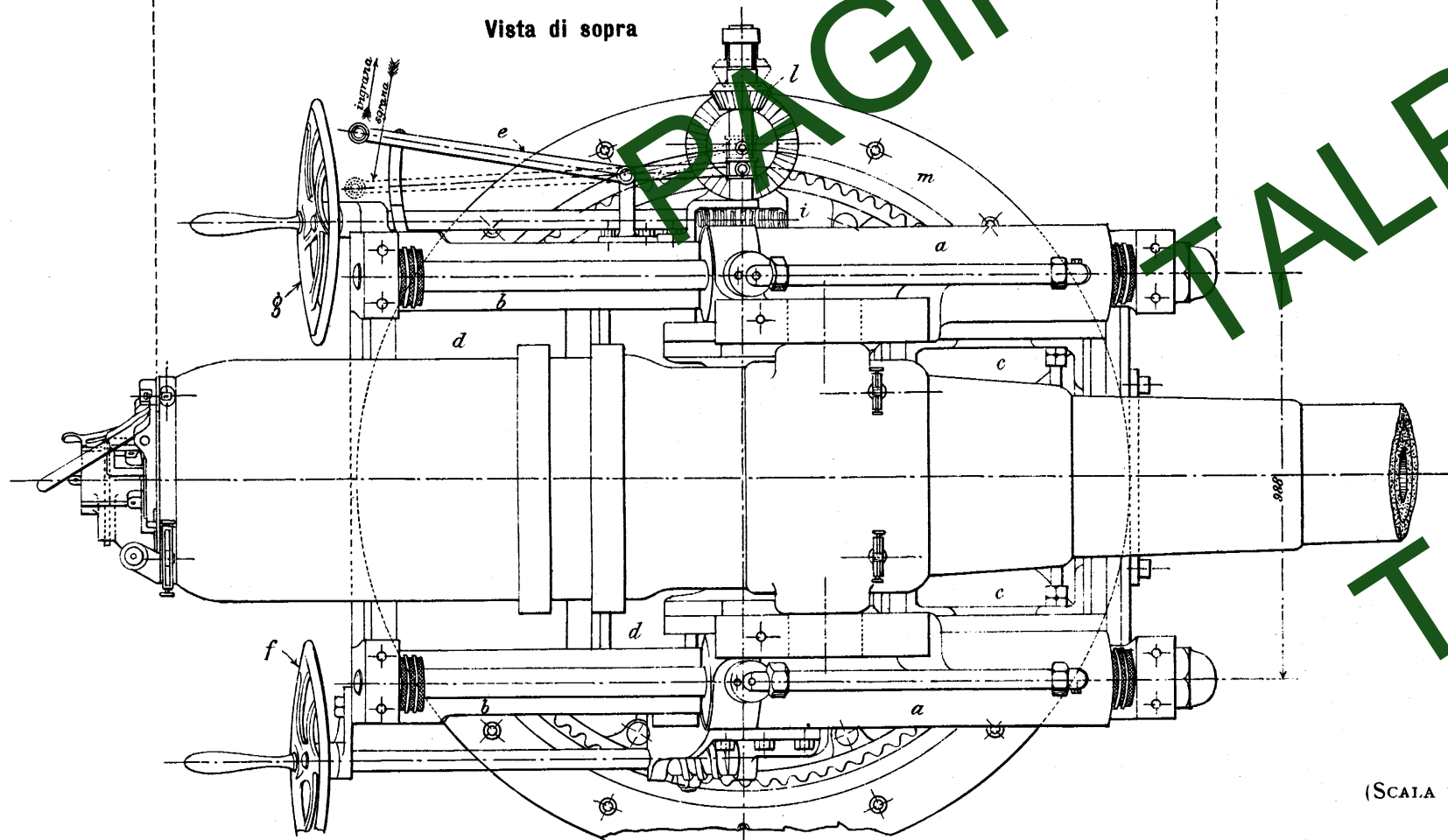

Congegno di rientramento e brandeggio  
Lato sinistro dell'affusto. - SCALA DI 1/10

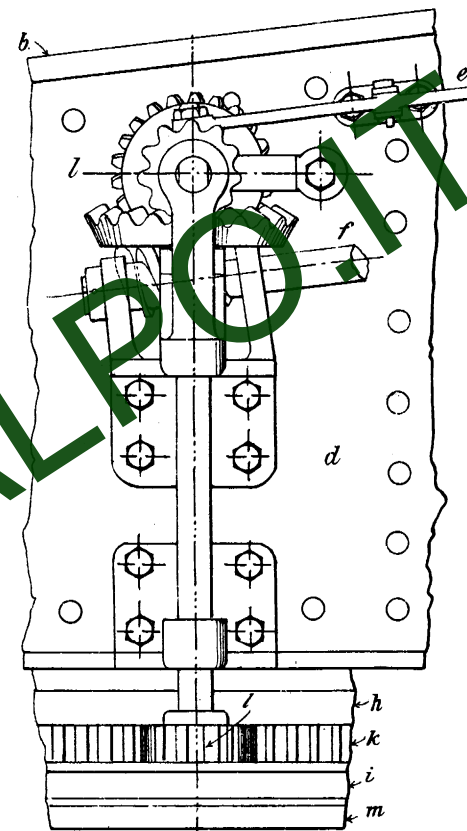

(SCALA DI 1/16)

INDICAZIONI

- a. Cilindri freno di rinculo
- b. Lisce per il ritorno in batteria
- c. Calastrello rientrante, collegato ai cilindri freno
- d. Cassone dell'affusto
- e. Leva per la manovra dell'ingranaggio del congegno di rientramento e brandeggio
- f. Volantino per la manovra del congegno di elevazione e depressione
- g. Volantino per la manovra del congegno di brandeggio, di mandata in batteria o rientramento
- h. Piattaforma girevole
- i. Piattaforma fissa
- j. Perno centrale di rotazione
- k. Corona dentata di brandeggio
- l. Rocchetti del congegno di brandeggio
- m. Rotaia circolare d'appoggio dei rulli
- n. Rulli dell'affusto, scorrevoli sulla rotaia
- o. Staffe dei rulli

Inclinazione delle lisce	7°
Lunghezza libera per il rinculo	mm. 700
Sforzo medio di rinculo	Kg. 20 137
Sforzo di strappamento	• 22 500
Sforzo di compressione	• 23 660
Quantità di liquido nei cilindri	litri 28,500

Su questo modello di affusto si possono incavalcare indifferentemente anche i cannoni da 152 B.

I particolari dei cilindri freno sono uguali a quelli rappresentati nella tavola N.º 29

DATI DI PESO

Affusto completo, compreso la piattaforma fissa	Kg. 6130
Scudo	• 2250
Cannone completo	• 5680

Peso totale Kg. 14060



AFFUSTO A PIEDESTALLO PER CANNONE DA 152 R. M.

Vista di fianco.

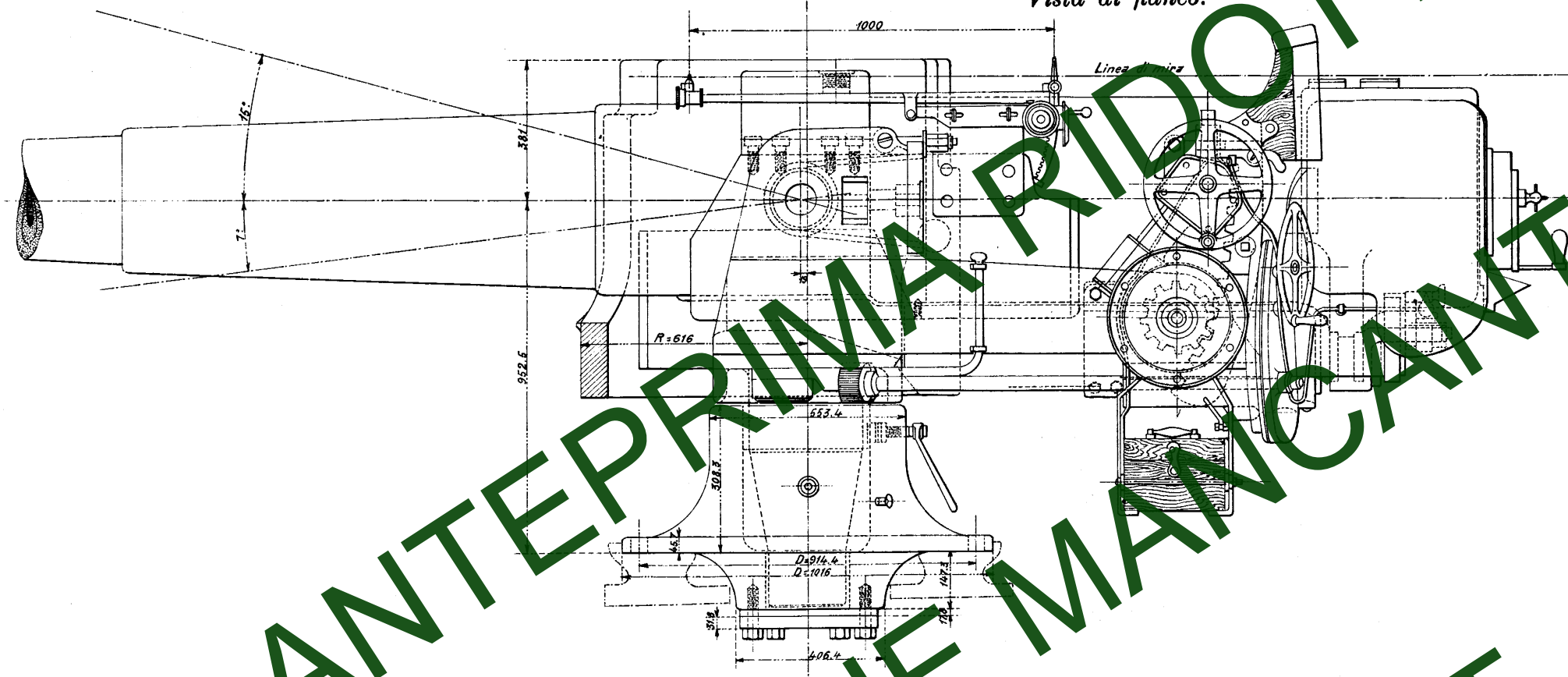

Vista posteriore.

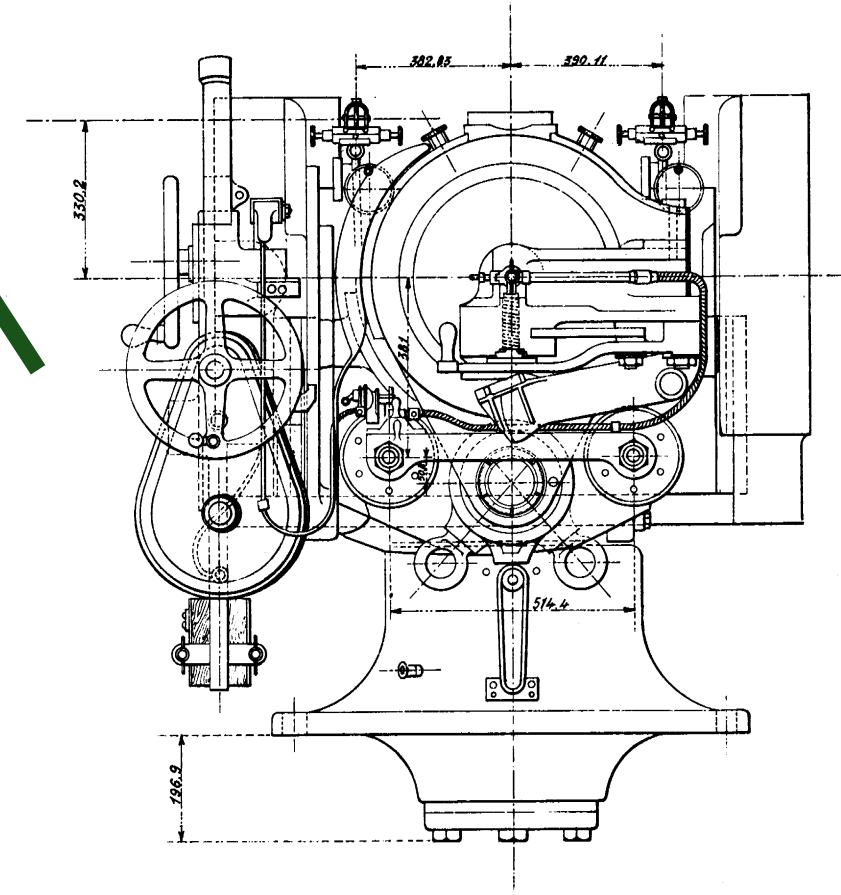

Vista di sopra.

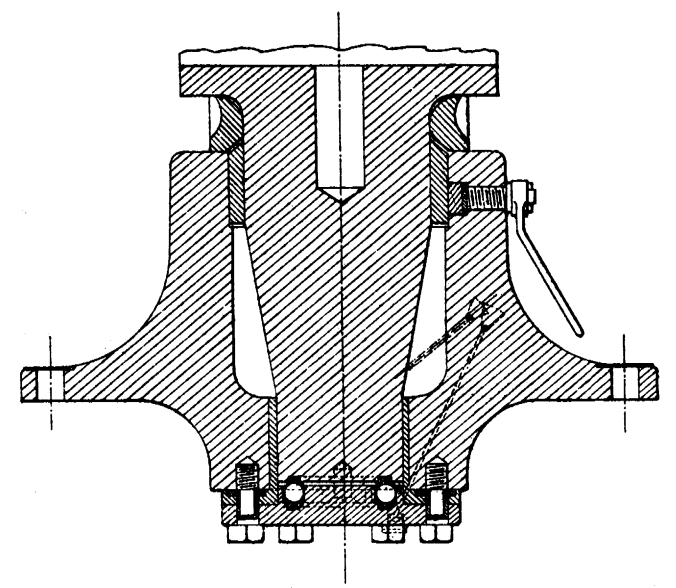
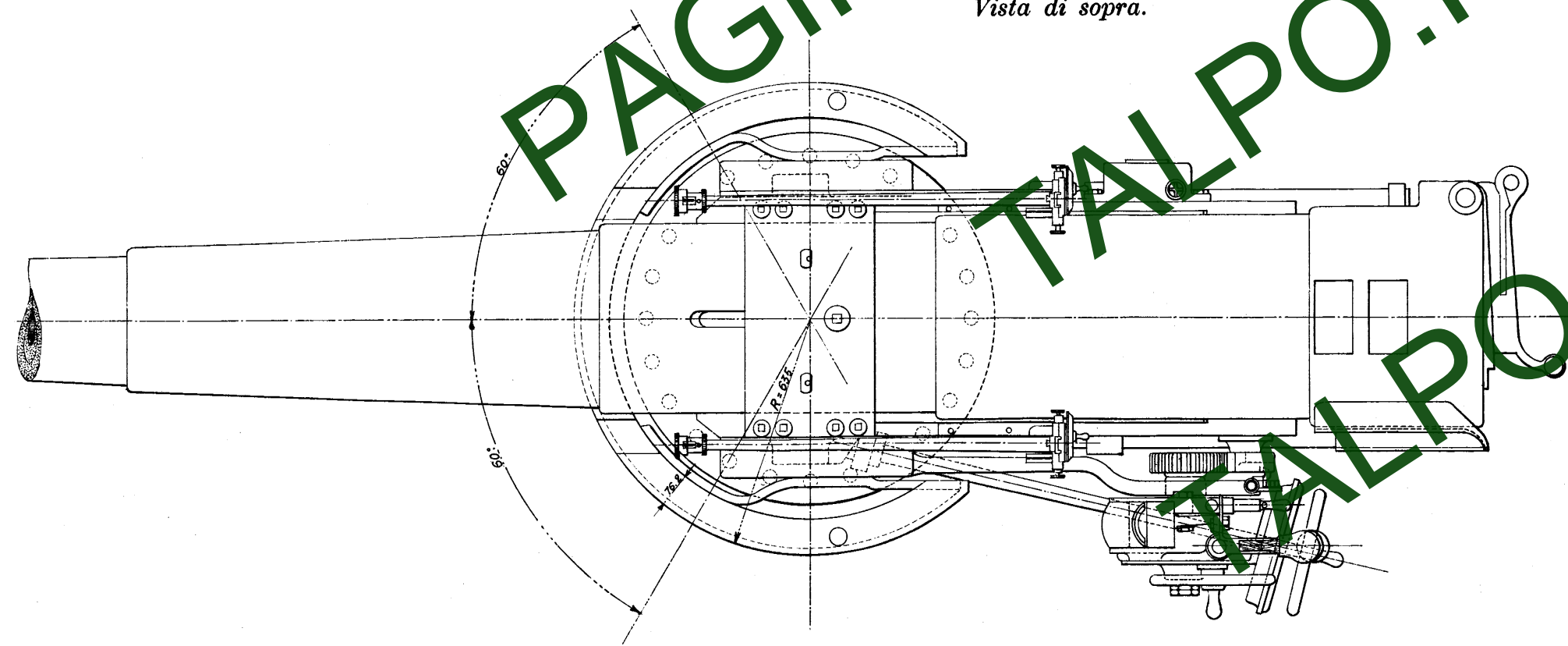

Scala di 1/16

ANTEPRIMA RIDOTTA  
PAGINE MANCANTI  
TALPO.IT

CANNONE DA 75 M. 911

Proiezione verticale SCALA DI 1/5

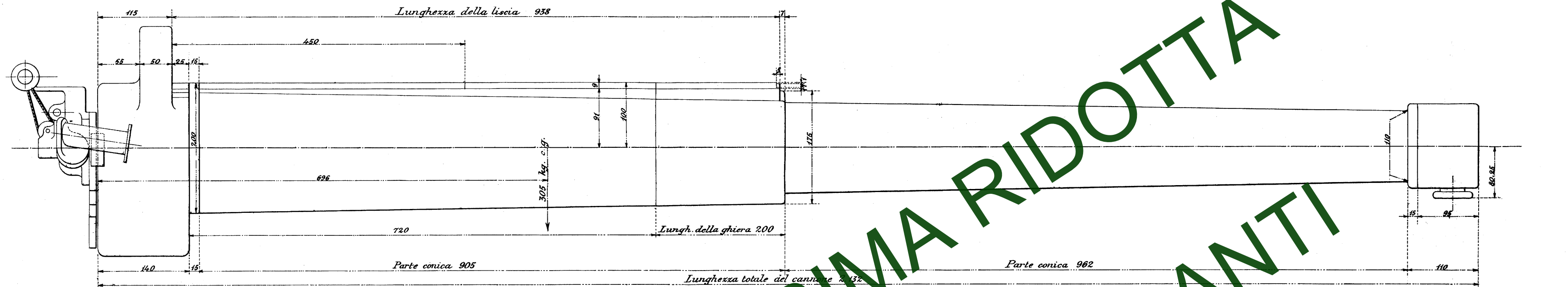

Sezione longitudinale

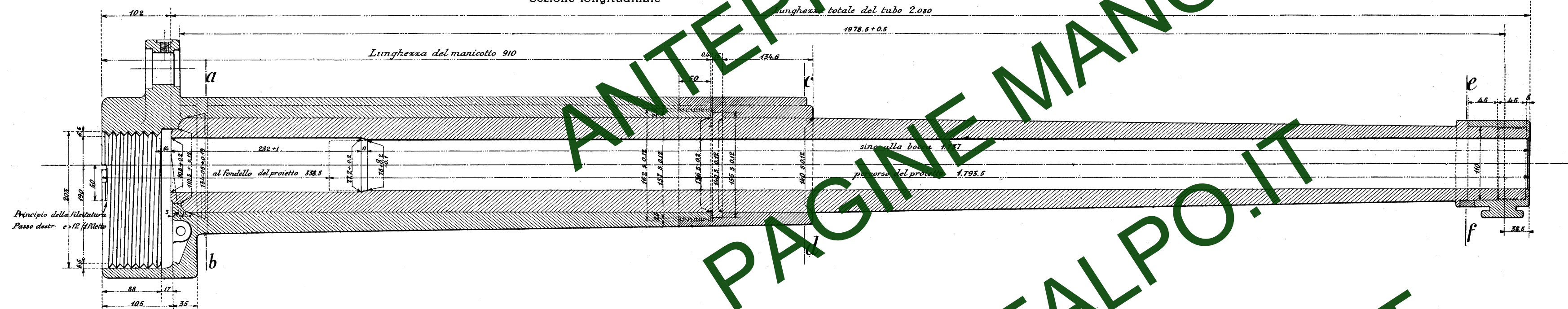

Proiezione orizzontale

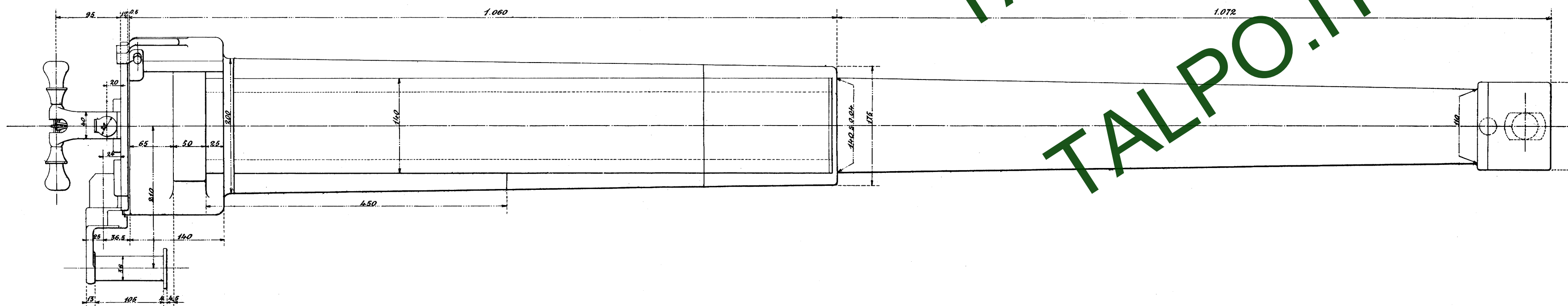

Visto della culatta

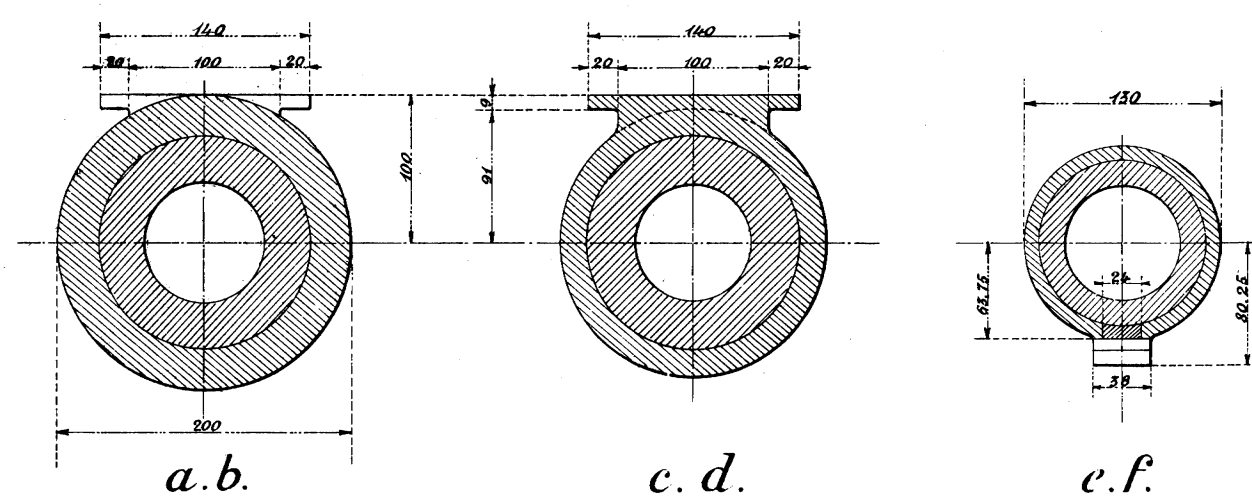
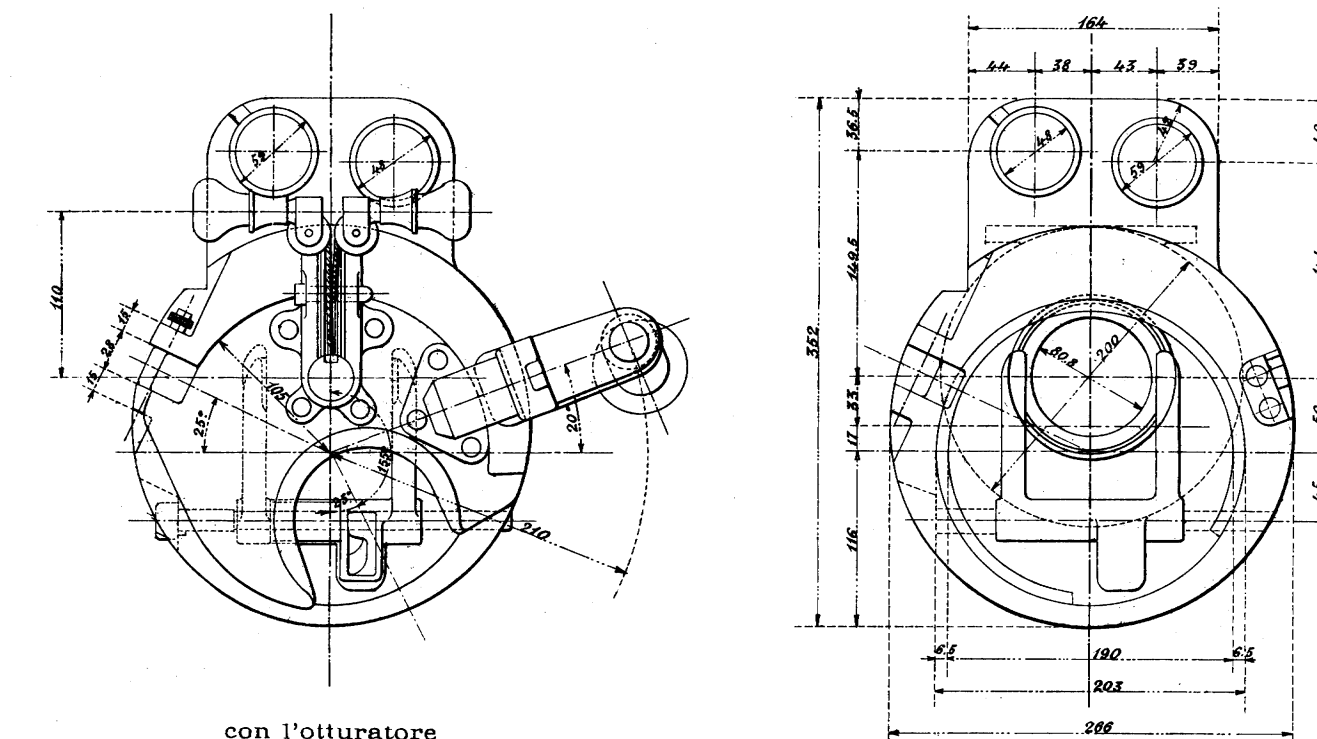

Sezioni trasversali



CANNONE DA 75 M. 911

Otturatore chiuso SCALA DI 1/2

Sezione verticale

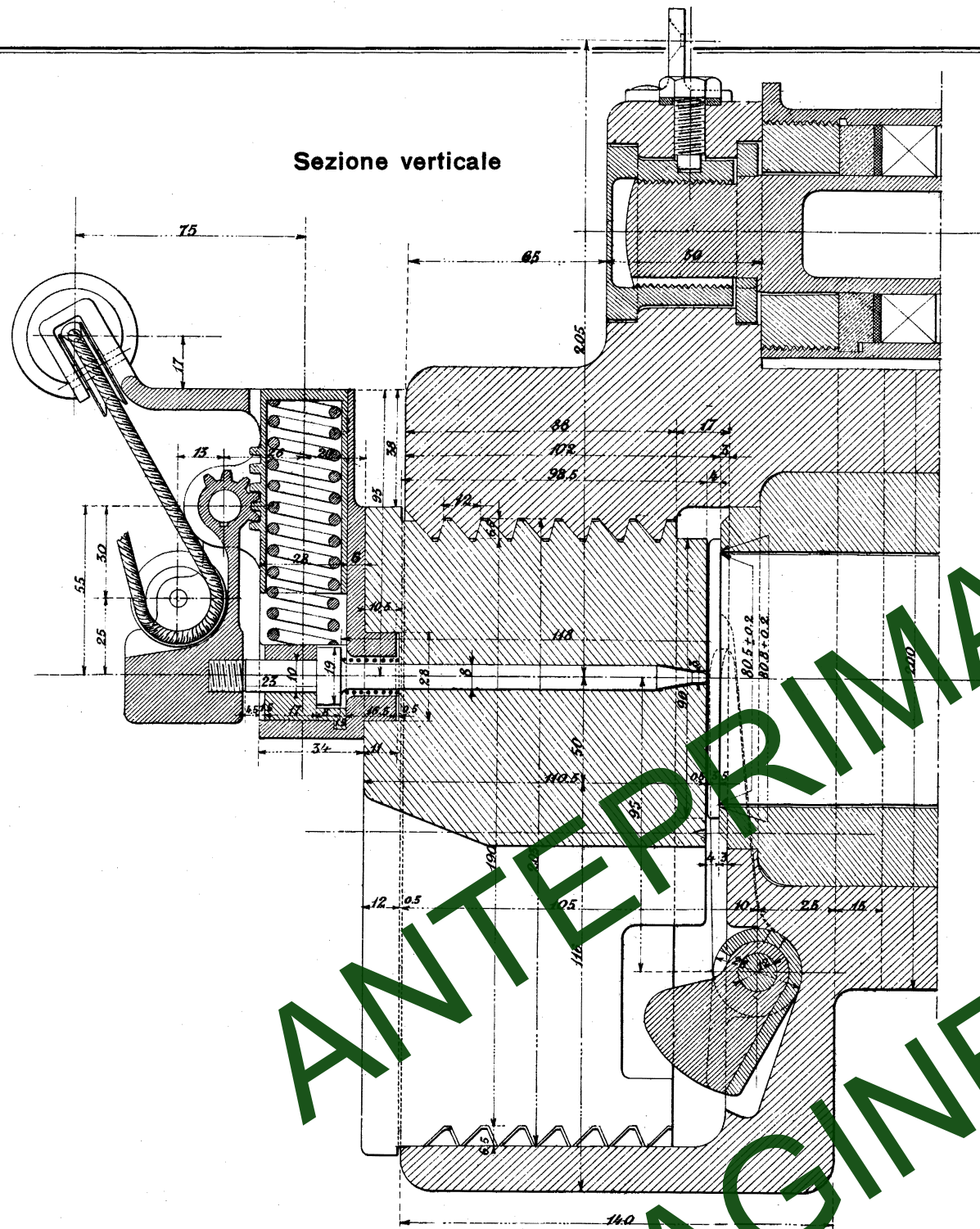

Visto posteriormente

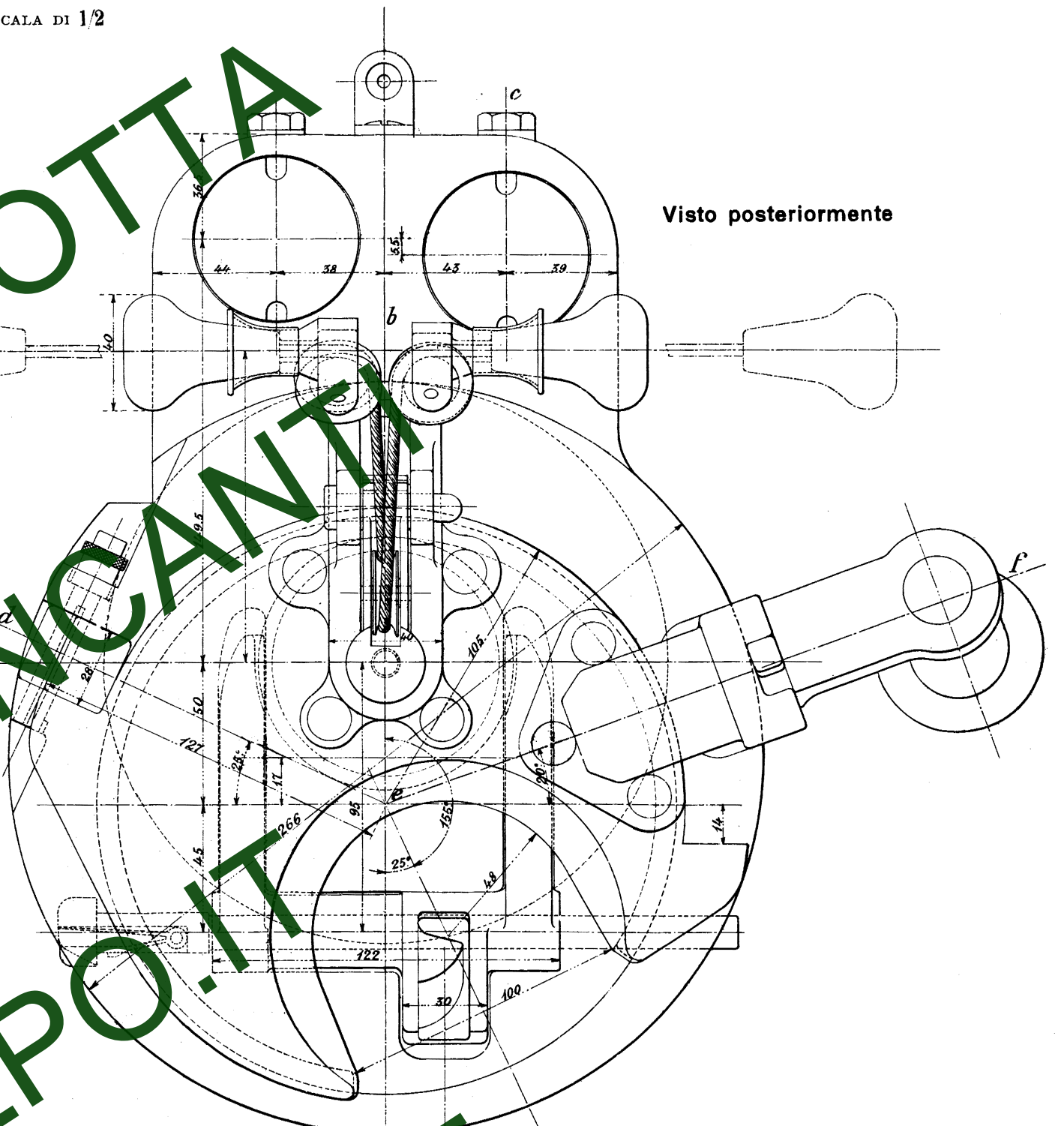

Sezione orizzontale

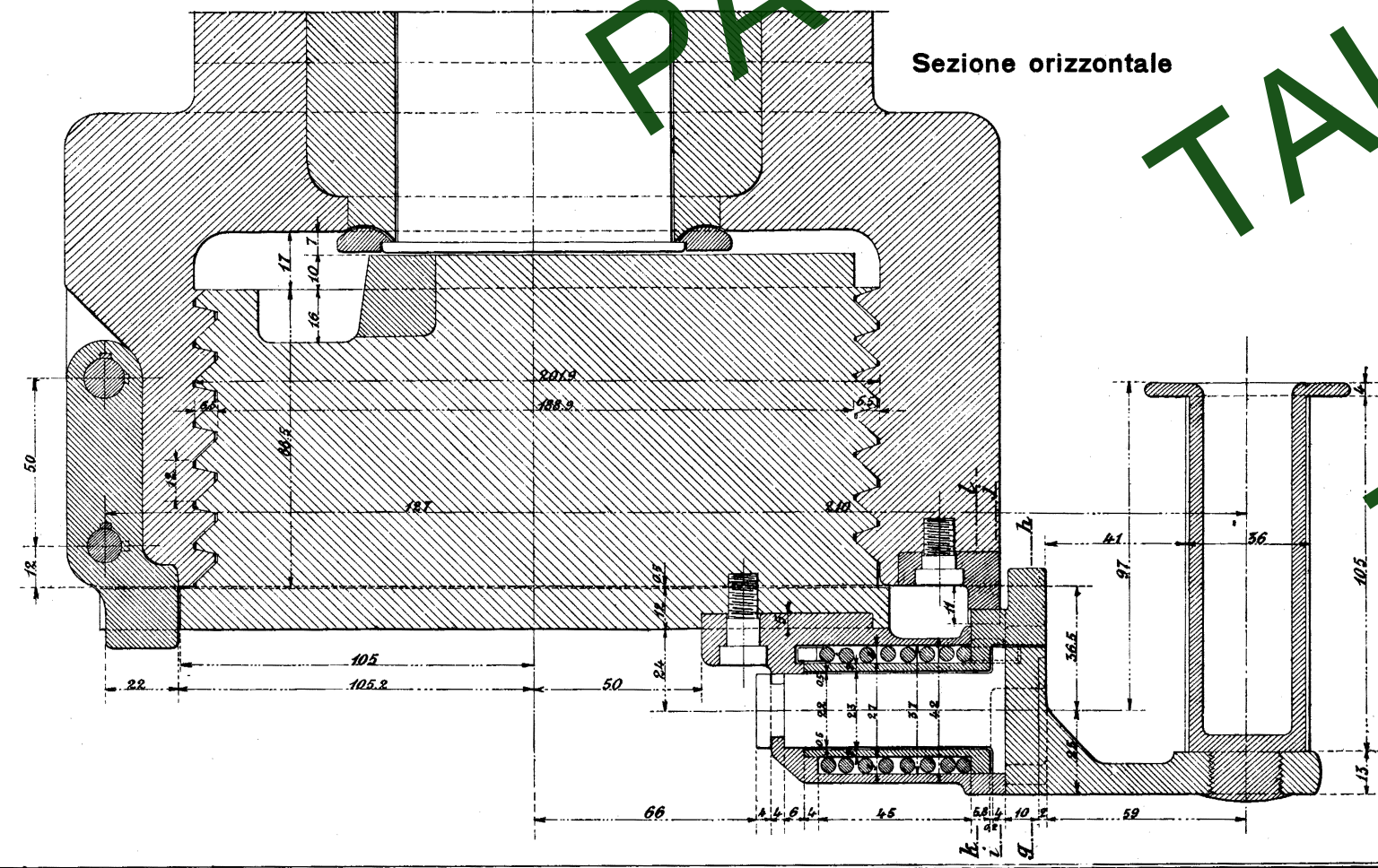

Congegno di sicurezza dell'impugnatura di maneggio

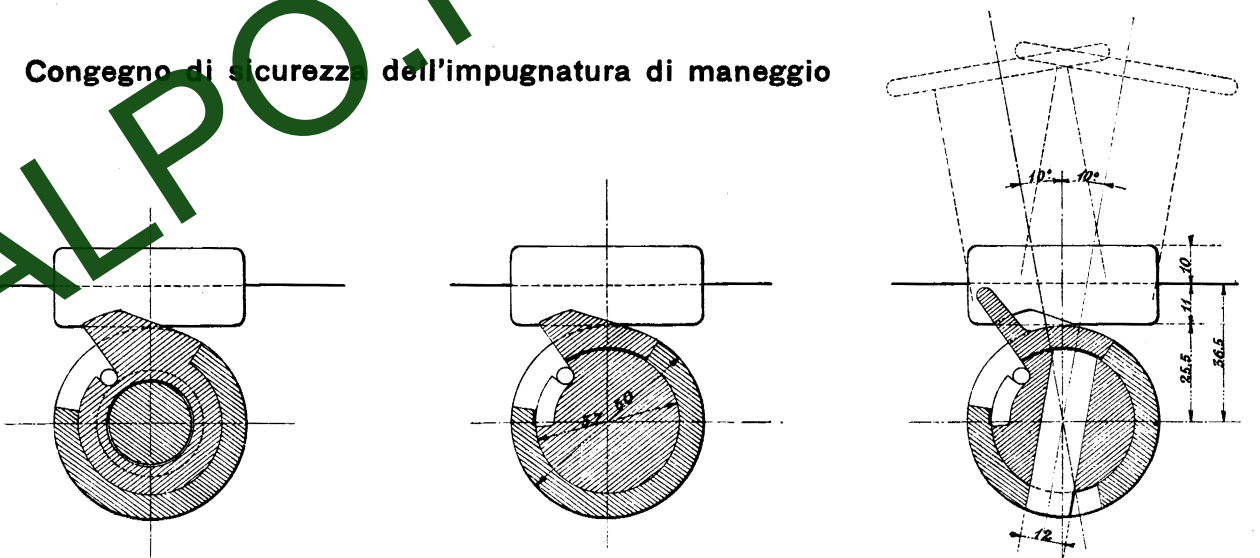

ANTEPRIMA RIDOTTA  
PAGINE MANCANTI  
TALPO.IT



# INNESCHI ESTERNI

SCALA 2/1

a bocchino anteriore

Mod. 79/99

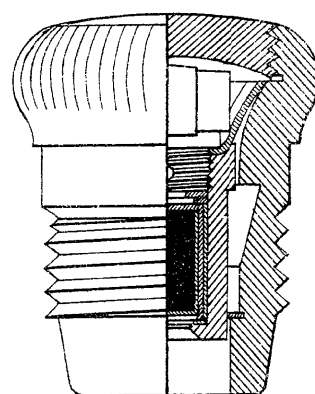

79  
99

Mod. 89/99

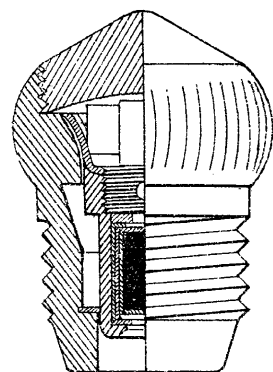

89  
99

Mod. 906

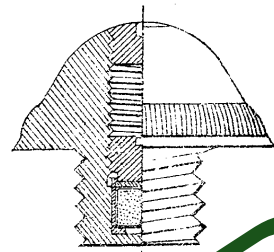

910

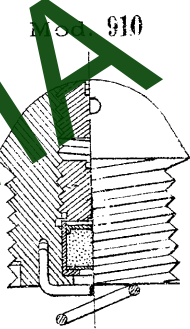

Mod. 79

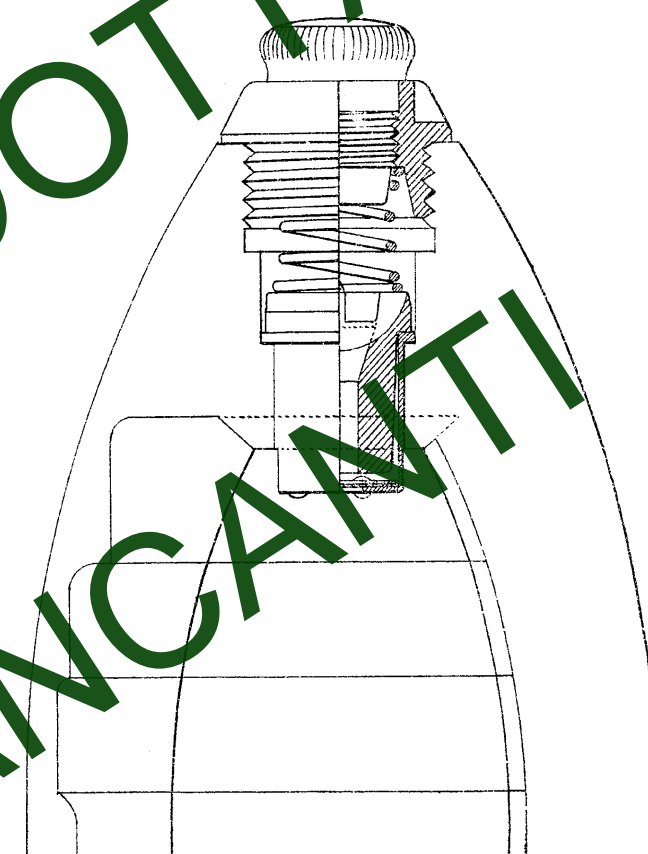

Mod. 85/903

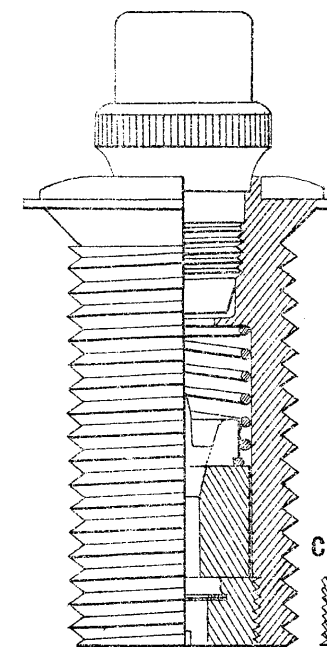

Mod. 89 904

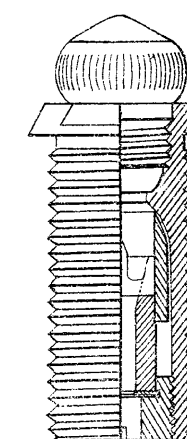

Codetta ritardataria

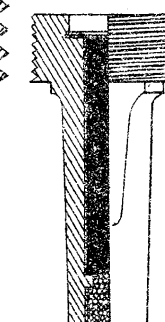

Mod. 85/99

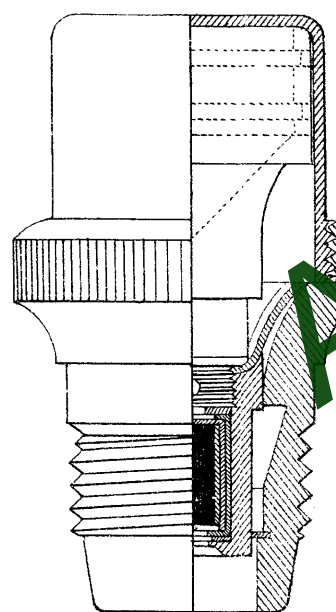

85  
99

Mod. 910

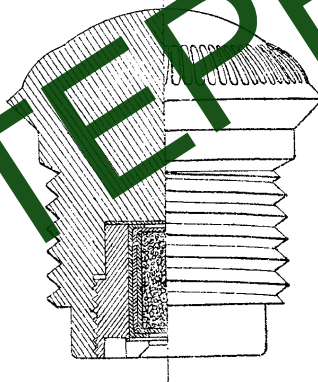

## SPOLETTE A PERCUSSIONE PER PROIETTI CARICHI DI POLVERE

a bocchino posteriore

Mod. 911 per r. 152 B e C

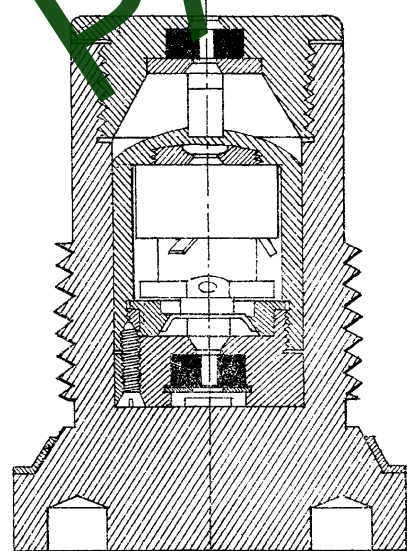

Per palle

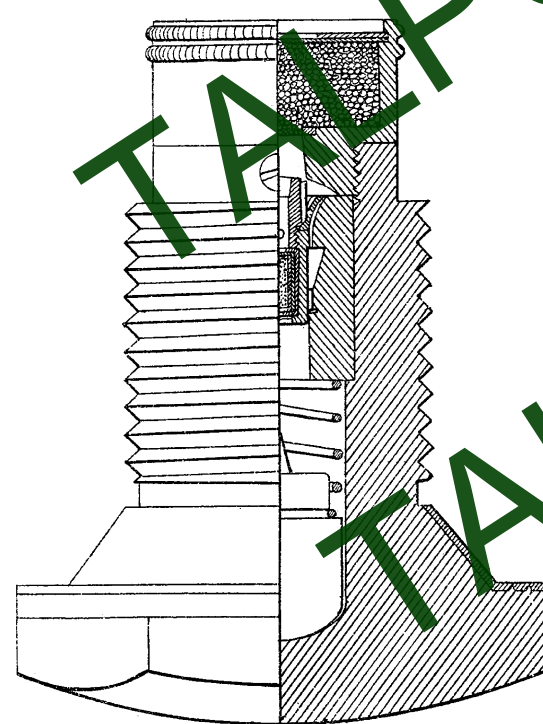

Per gr. da 280, cariche di polvere

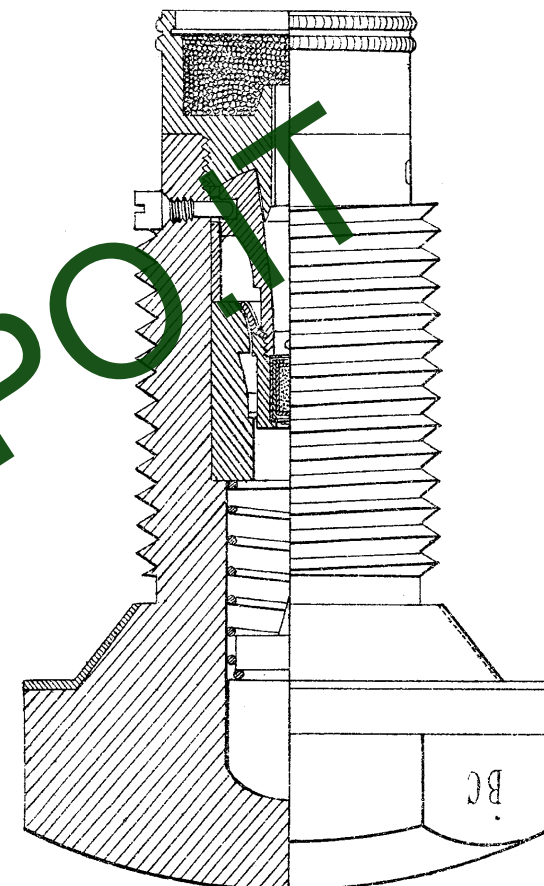

A 97/913 per gr. ghisa  
indurita da 152 B e C

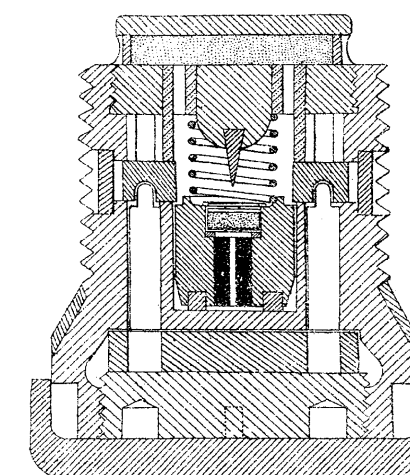

SCALA 1/1

ANTEPRIMA RIDOTTA  
PAGINE MANCANTI  
TALPO.IT



SPOLETTE A PERCUSSIONE PER PROIETTI CAPICHI  
DI POTENTE ESPLOSIVO A BOCCHINO ANTERIORE

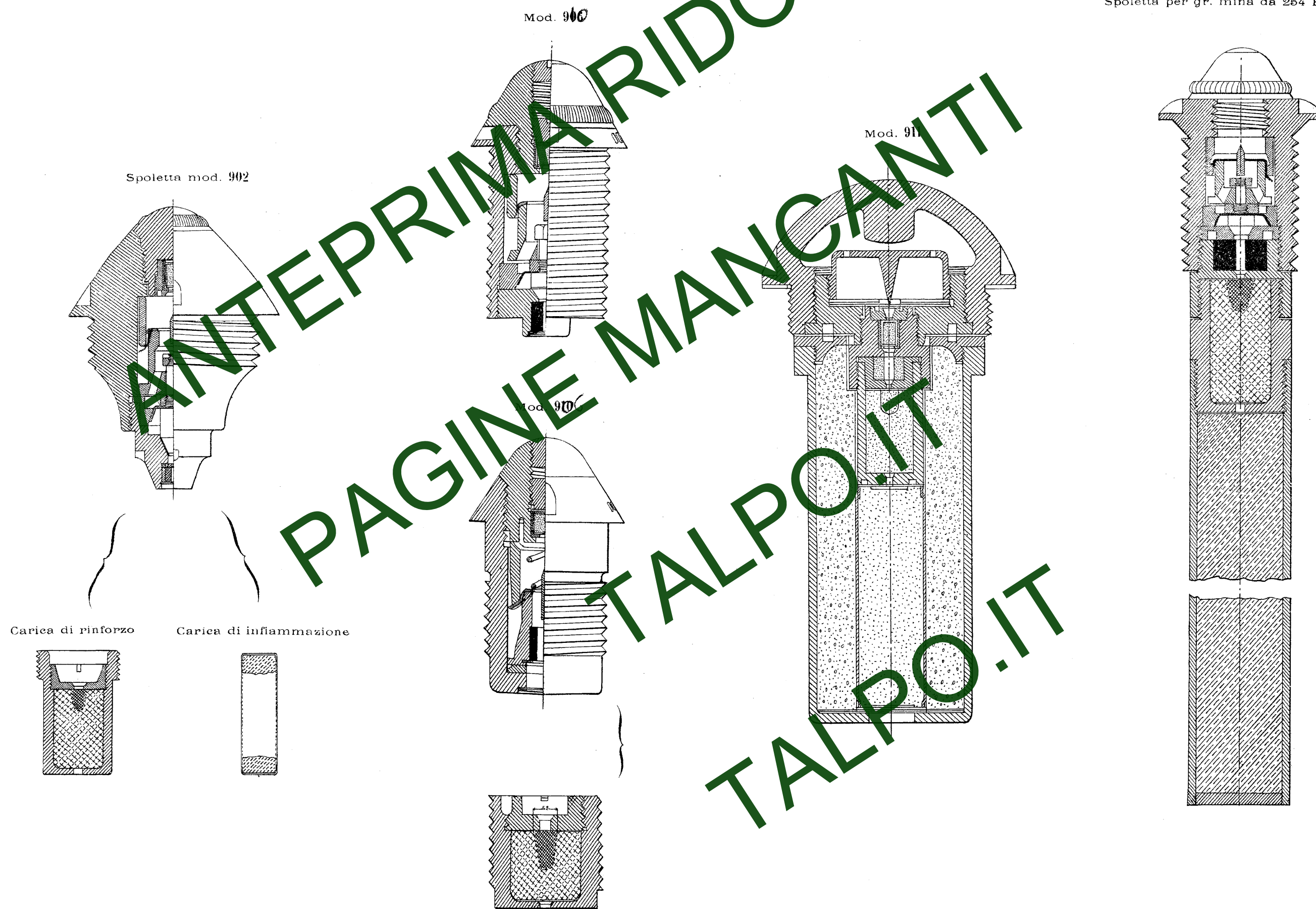



SPOLETTE A DOPPIO EFFETTO

SPOLETTE A TEMPO

Mod. 76

(a millimetri)

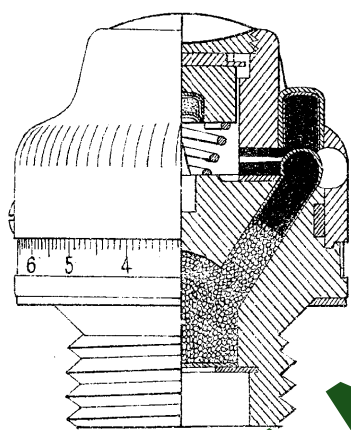

Per mortai da 87

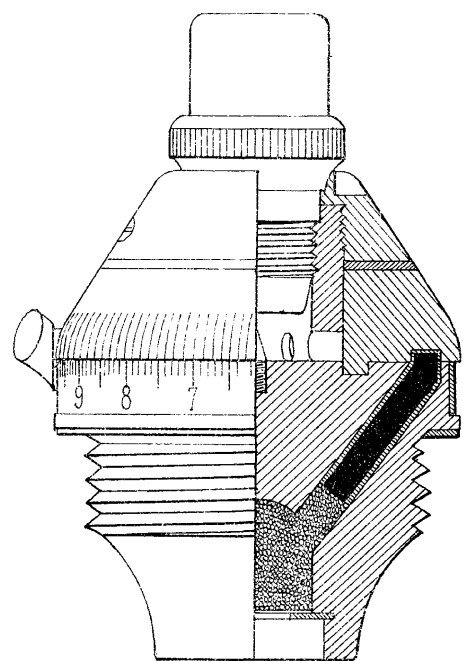

Mod. 86

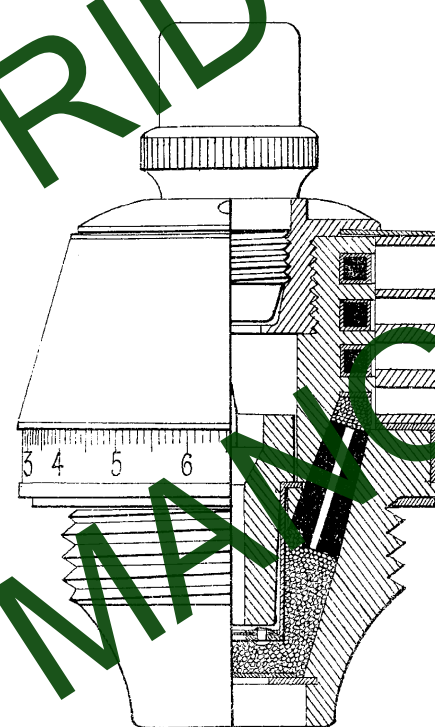
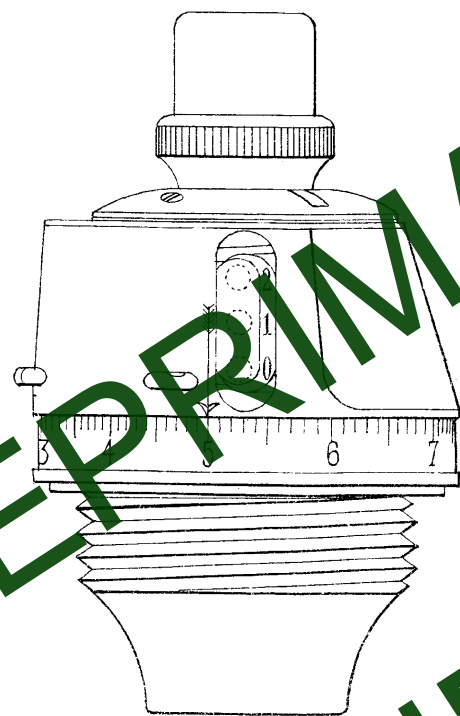

Mod. 87

(da 87)

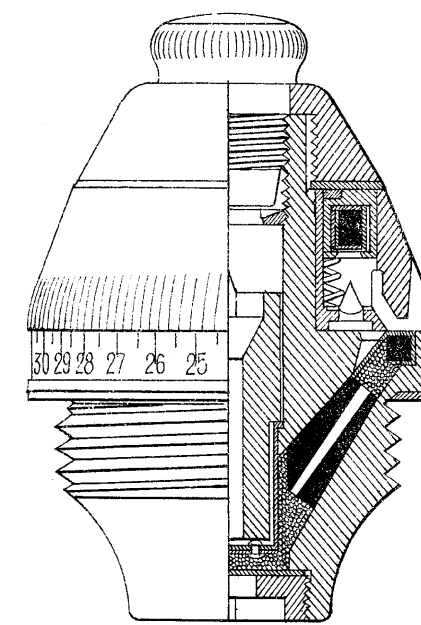
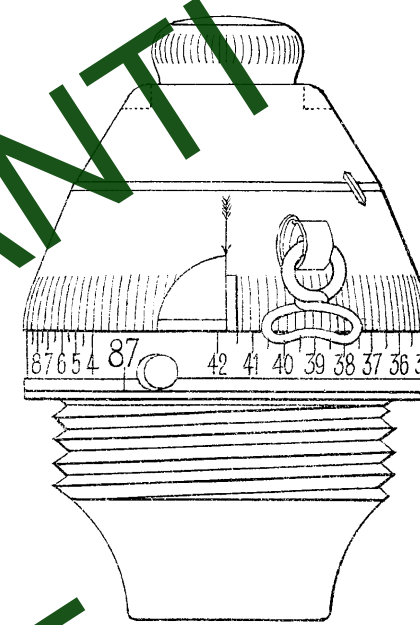

Mod. 90

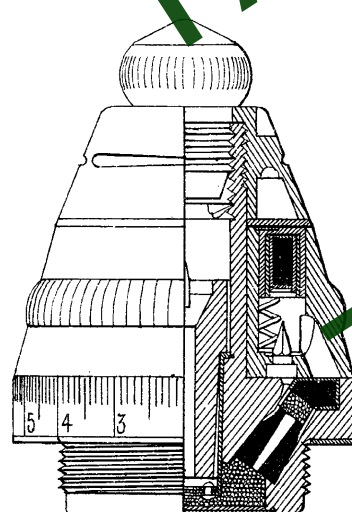
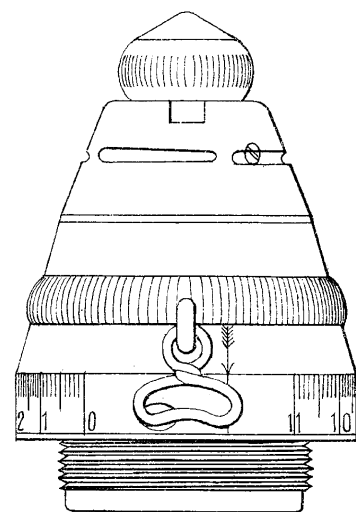

Mod. 99

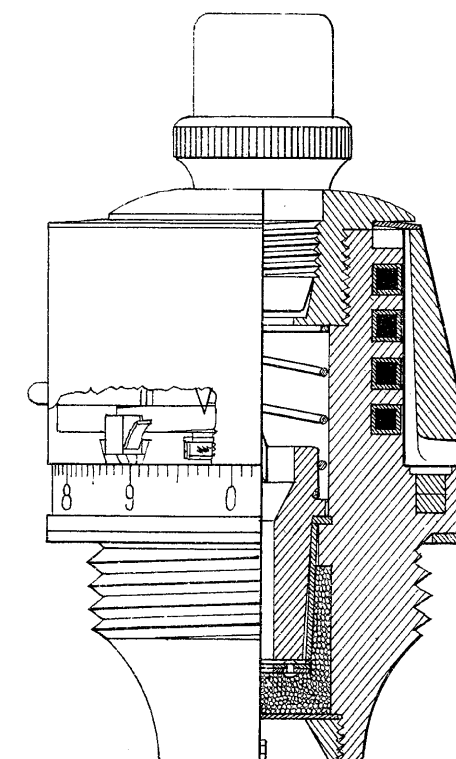
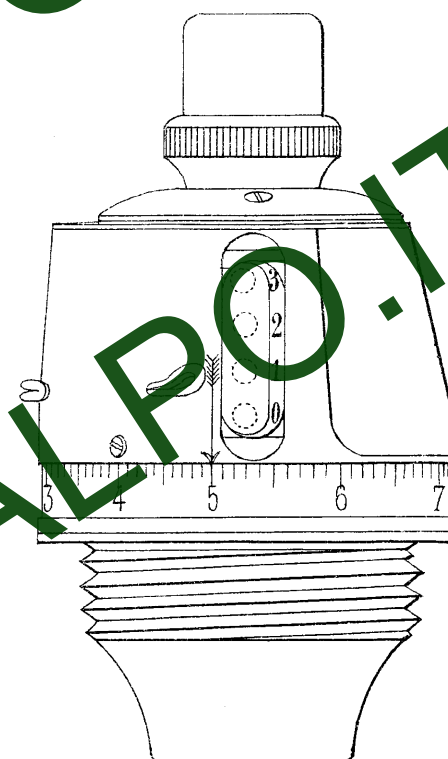

Scala di 1/1

ANTEPRIMA RIDOTTA  
PAGINE MANCANTI  
TALPO.IT



SPOLETTE A DOPPIO EFFETTO RECENT

Mod. 900

da 65

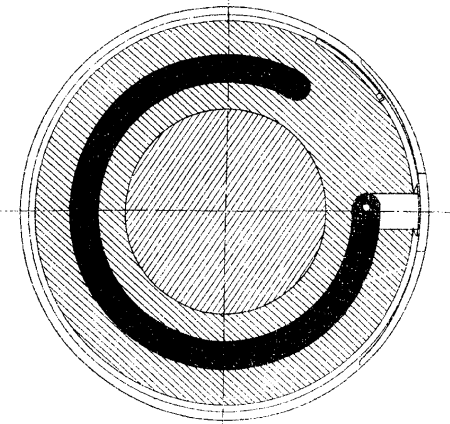
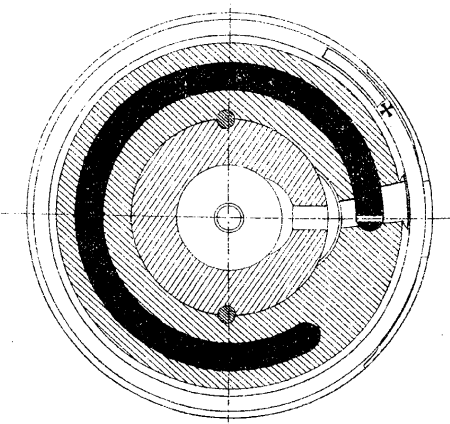
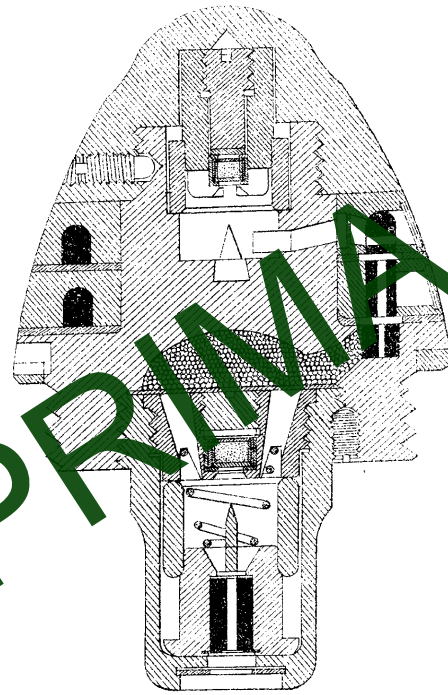
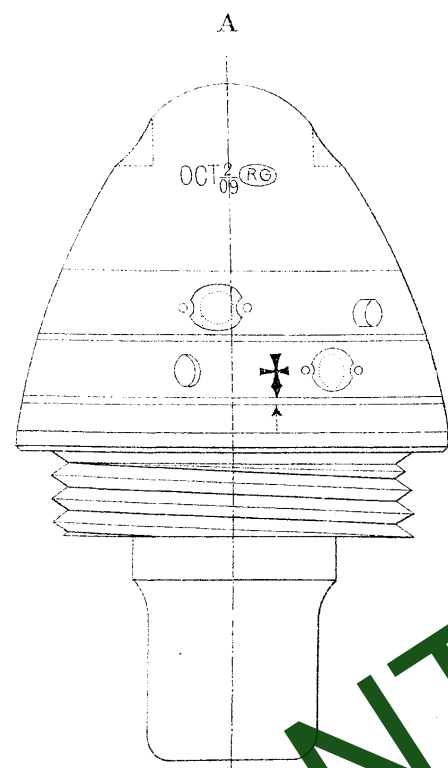

Mod. 906

per obice da 149

Campale pesante

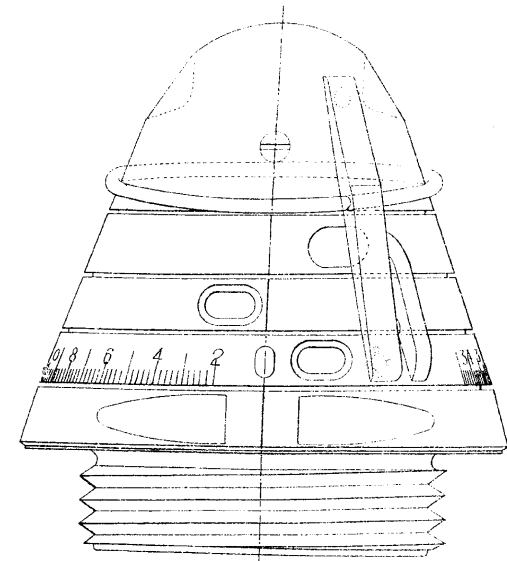
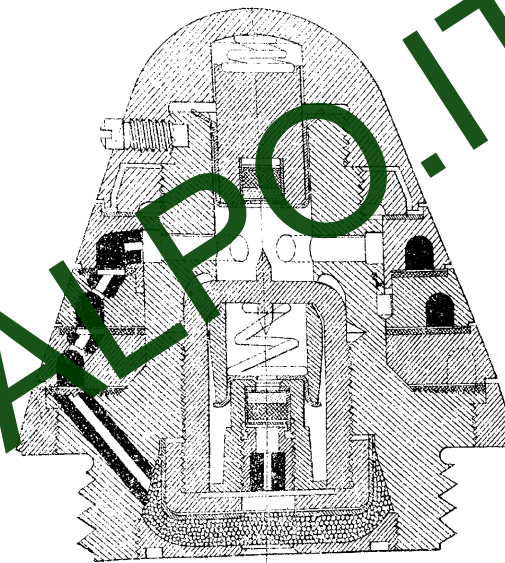
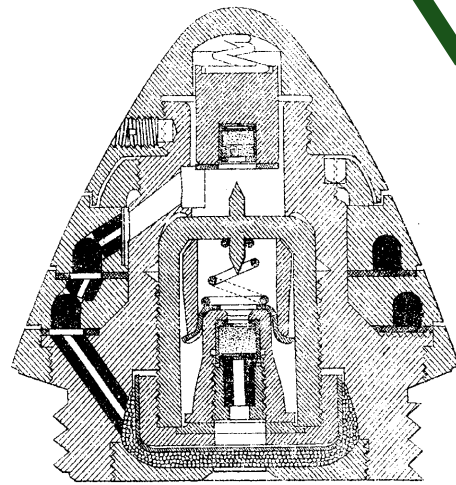
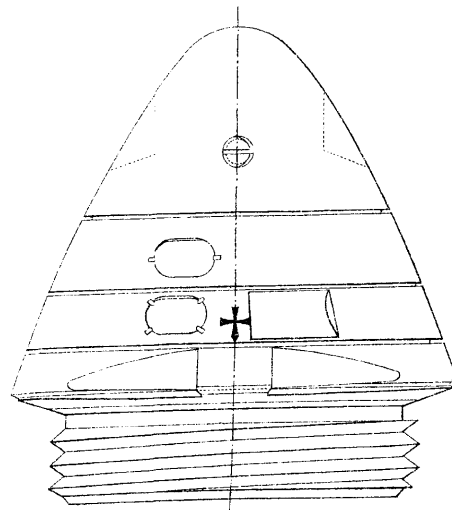

ANTEPRIMA RIDOTTA  
PAGINE MANCANTI  
TALPO.IT



GRANATA DA 75/906 MOD. 1910

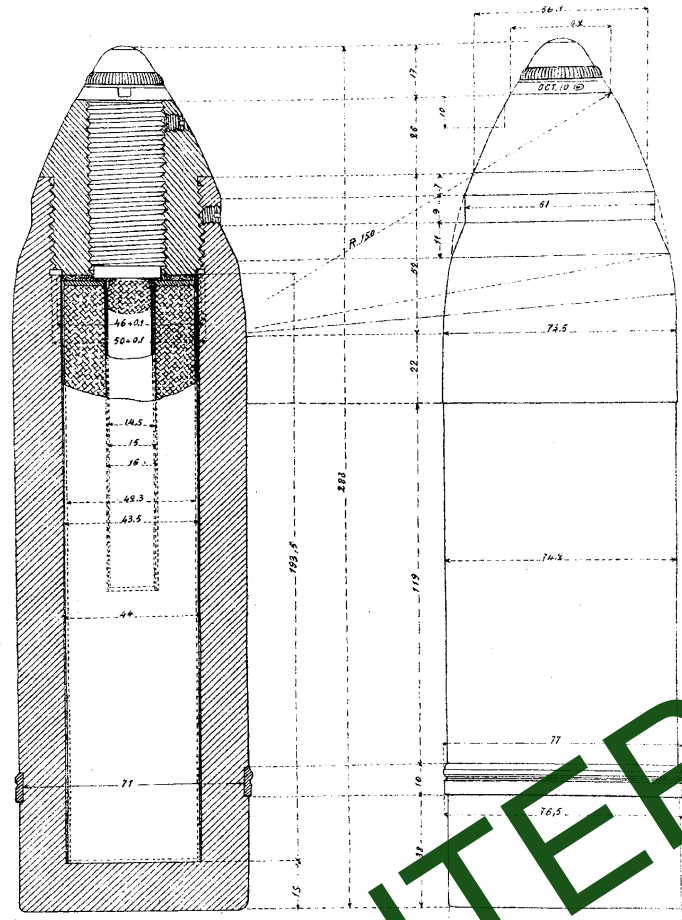

SPOLETTA A PERCUSSIONE MOD. 1910

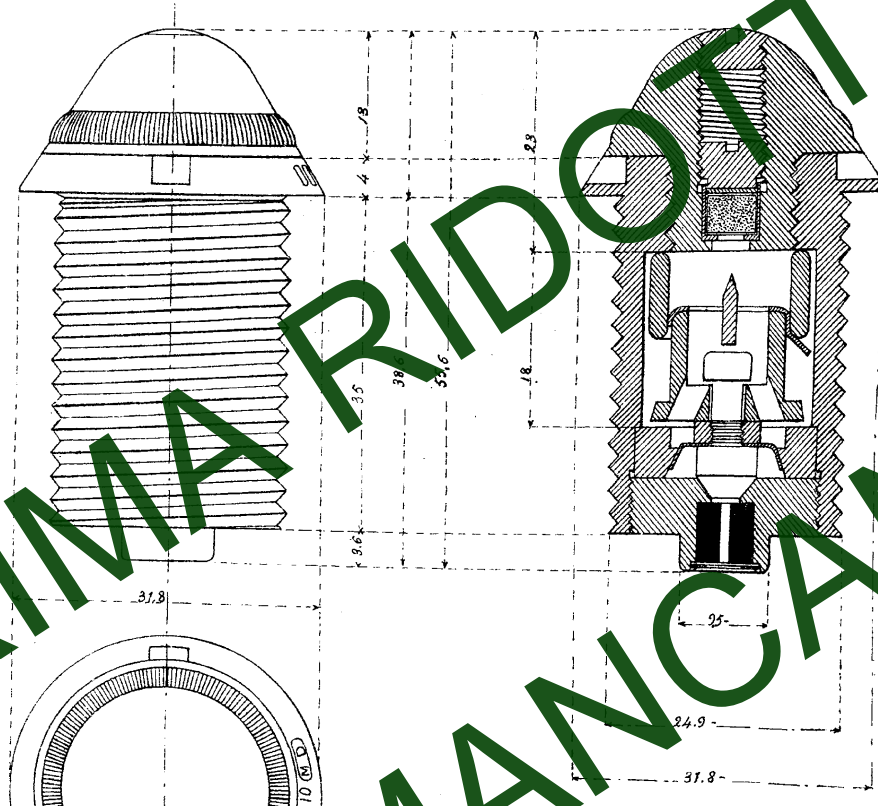

SPOLETTA A PERCUSSIONE MOD. 1906

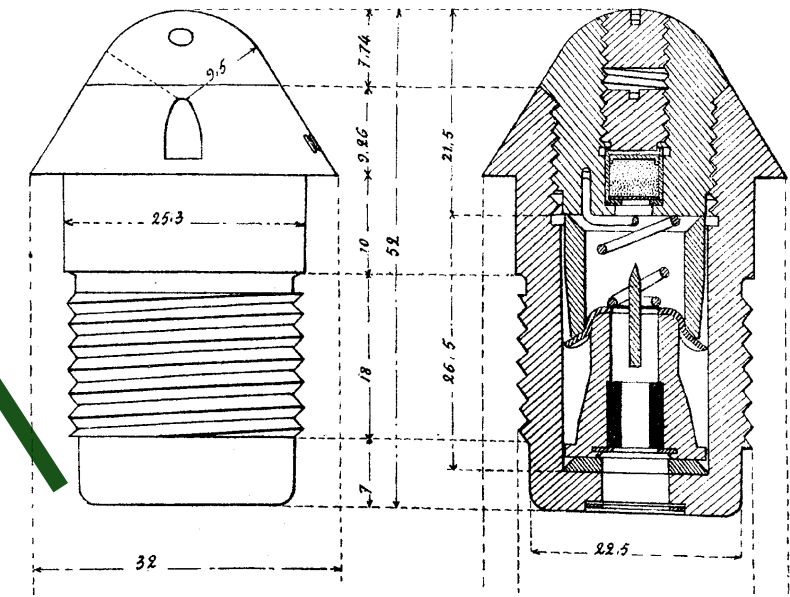

CARICA DI RINFORZO PER GRANATA  
Scala 1/1

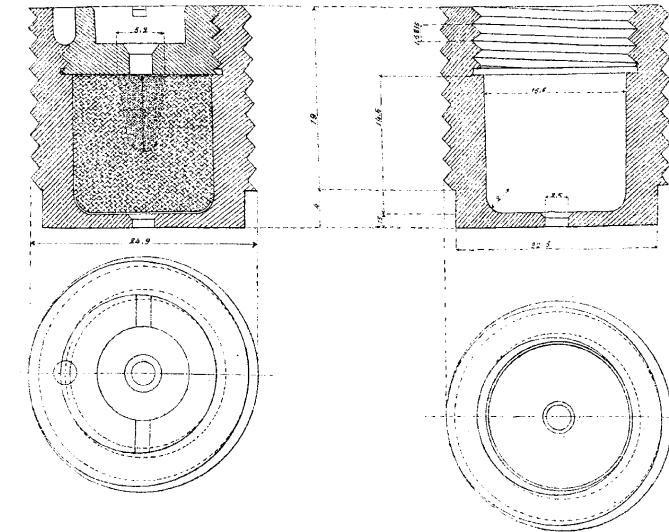

Carica  
d'inflammation  
per granata



SHR...  
Scala 1/3

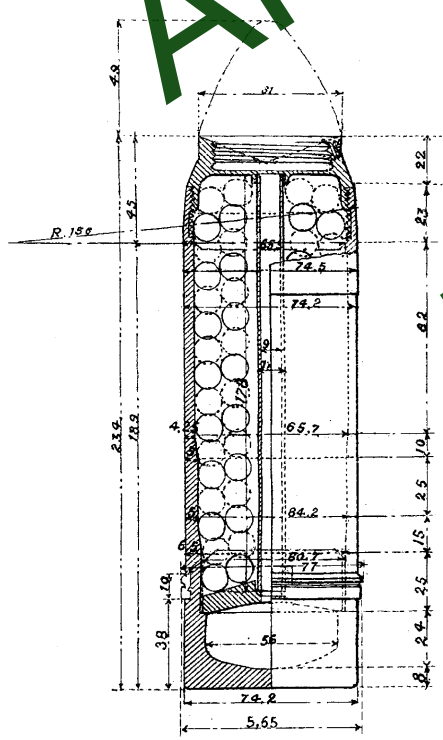

SPOLETTA A DOPPIO EFFETTO MOD. 1906

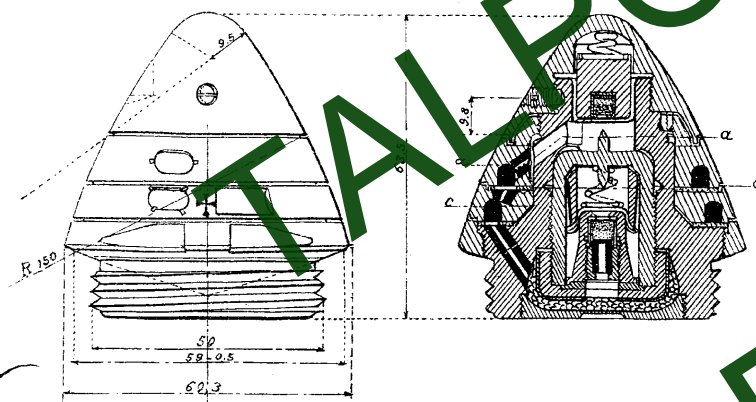

Sezione del congegno a tempo

TALPO.IT

PROIETTO ECONOMICO  
Scala 1/3

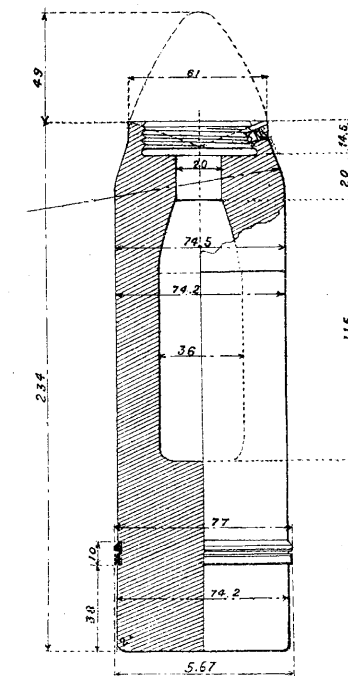

Sezione c c

Sezione a a

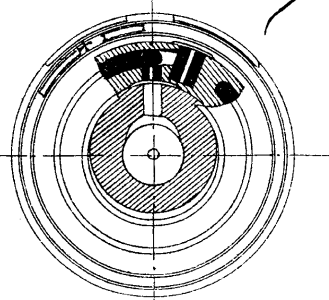
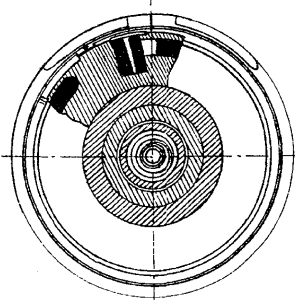



SHRAPNEL

da 210

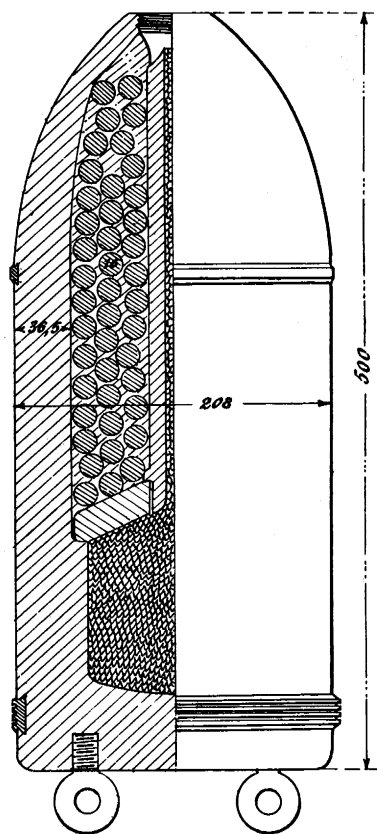

SCALA 1/5

DI GHISA

da 149

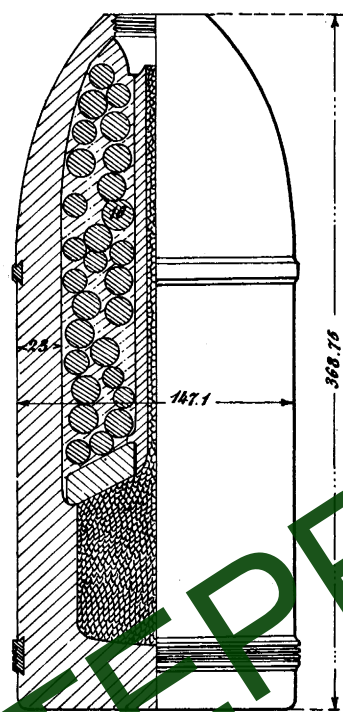

SCALA 1/4

da 120



SCALA 1/4

da 87 a

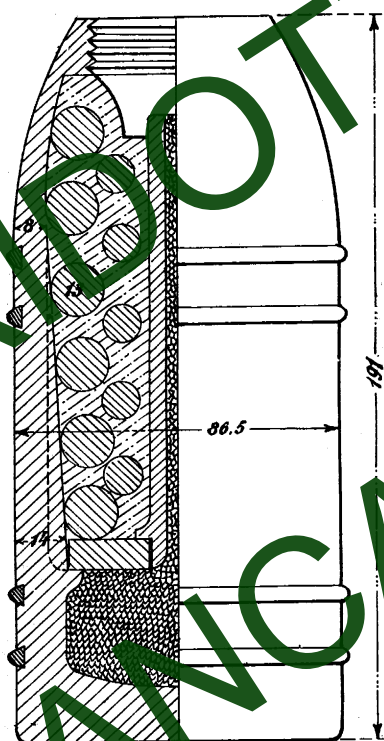

SCALA 1/2

da 152 A. B. C.

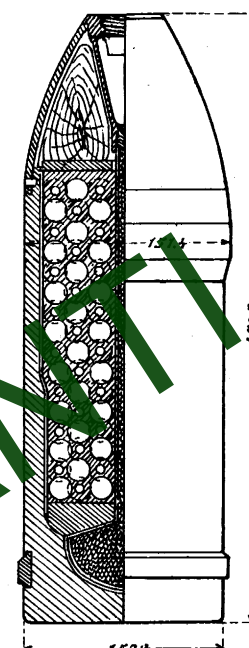

SCALA 1/6

DI ACCIAIO

da 152/50

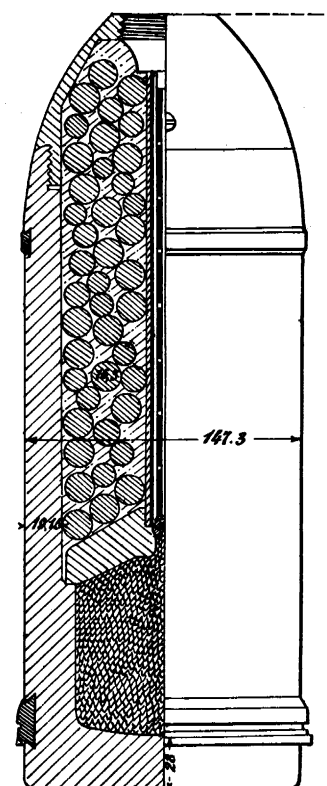

SCALA 1/4

da 149 S.

per obice da 149 A camp.

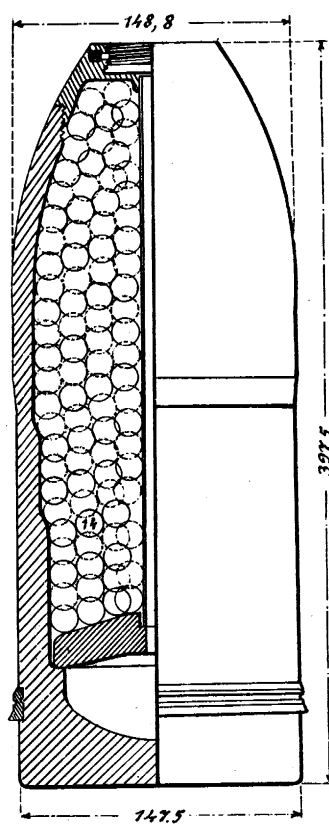

SCALA 1/4

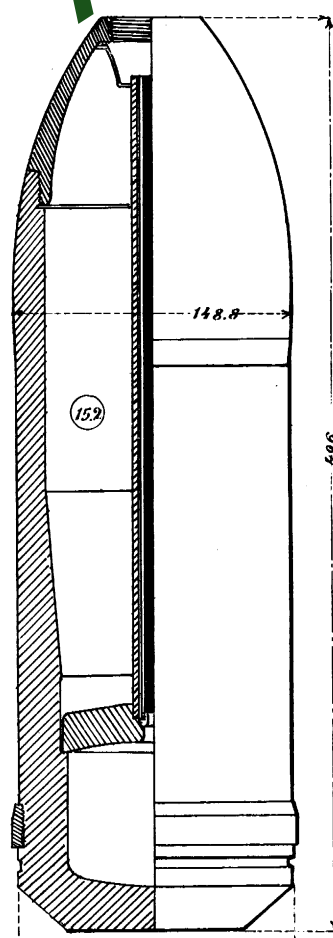

SCALA 1/4

da 120 A. L.

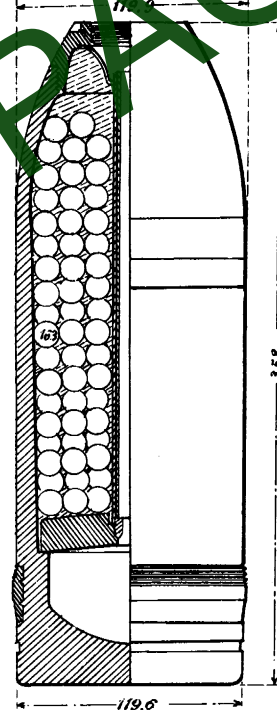

SCALA 1/4

da 75 A.

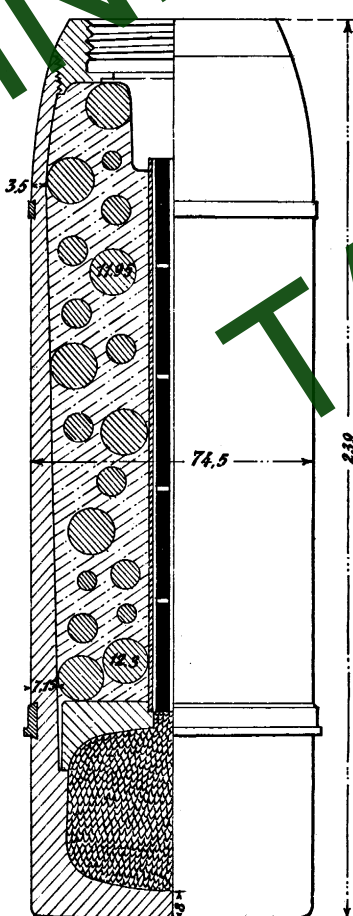

SCALA 1/2

da 70

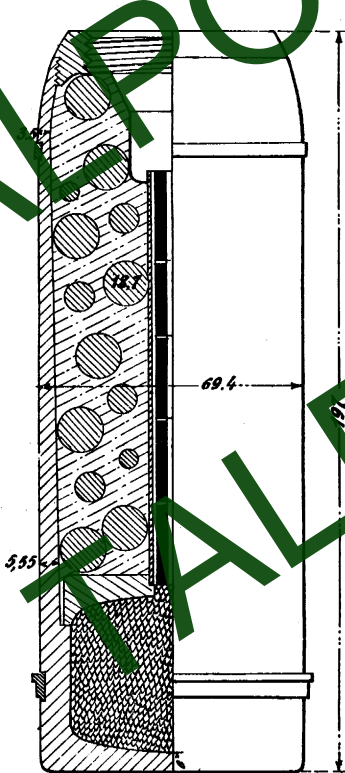

SCALA 1/2

da 75/906

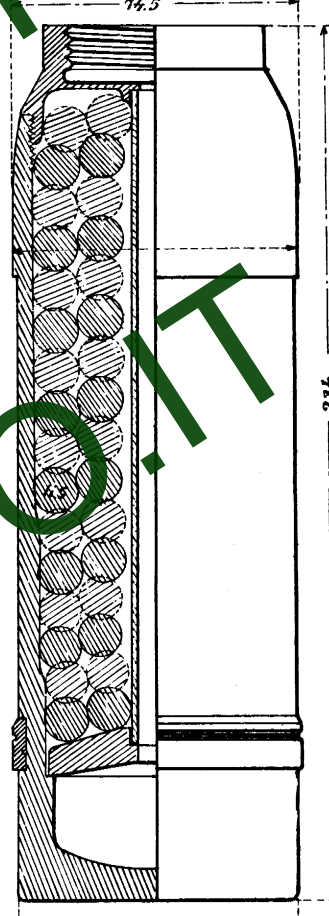

SCALA 1/2

da 65

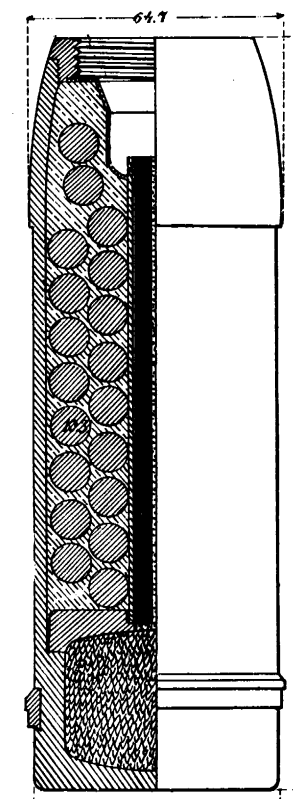

SCALA 1/2

da 57

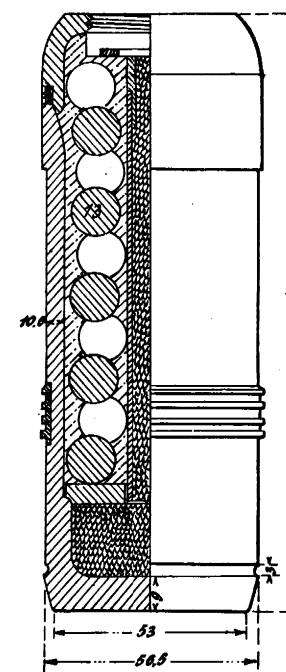

SCALA 1/2

ANTERPRIMA RIDOTTA  
PAGINE MANCANTE  
TALPO.IT



AFFUSTO PER CANNONE DA 65-FRENO A CULLA E SLITTA

SCALA 1/4

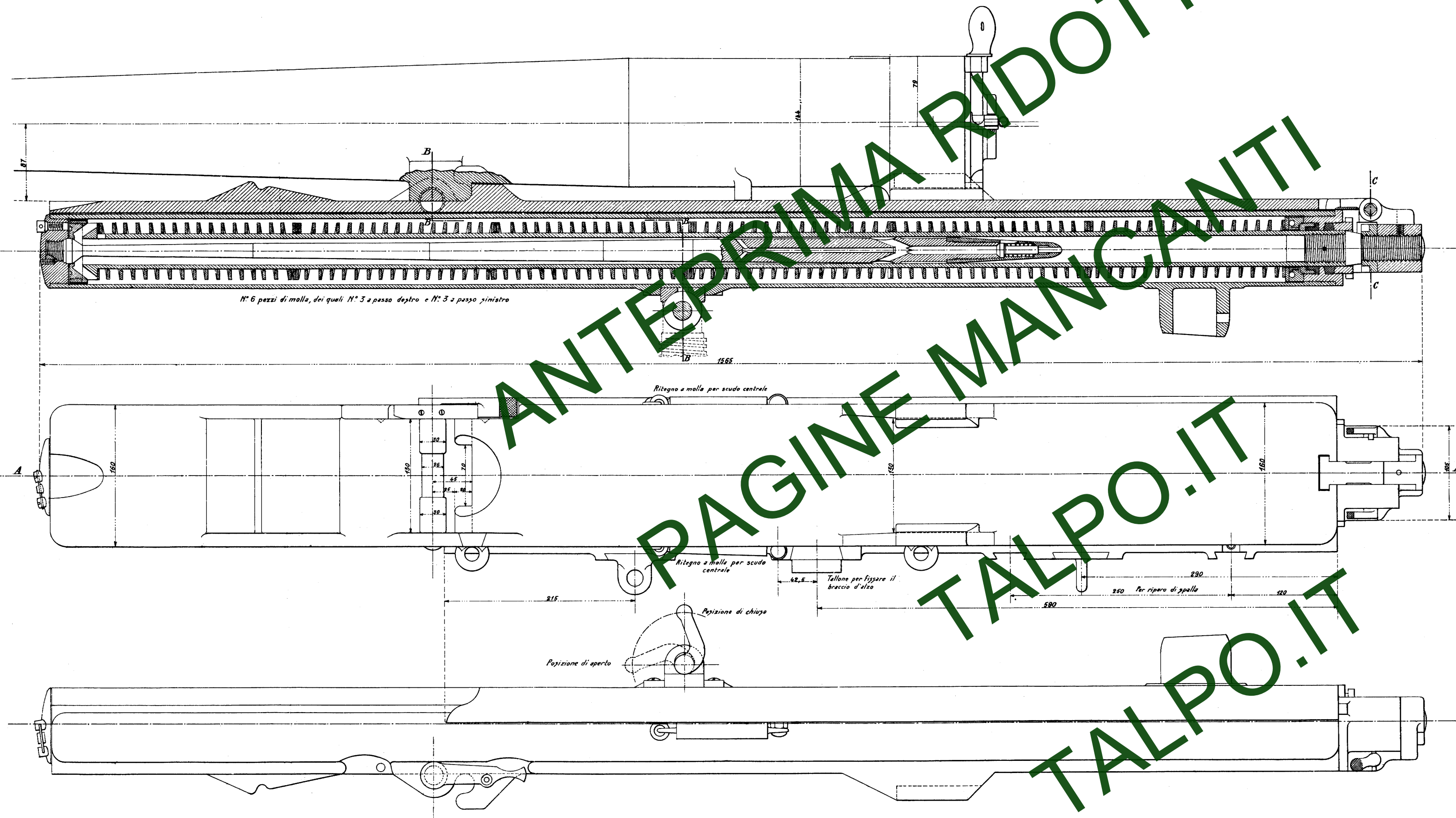

Proiezione della testata anteriore

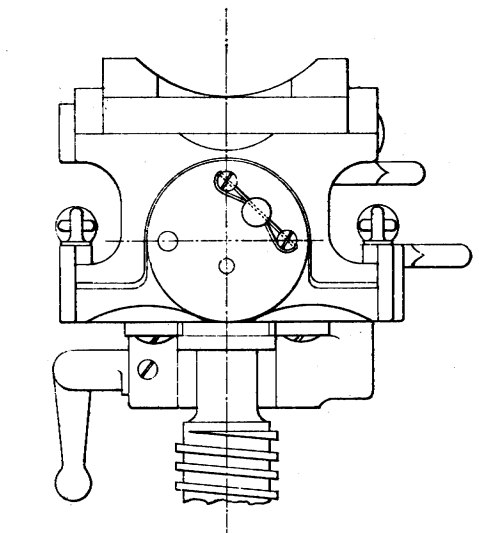

Sezione verticale sulla linea B B

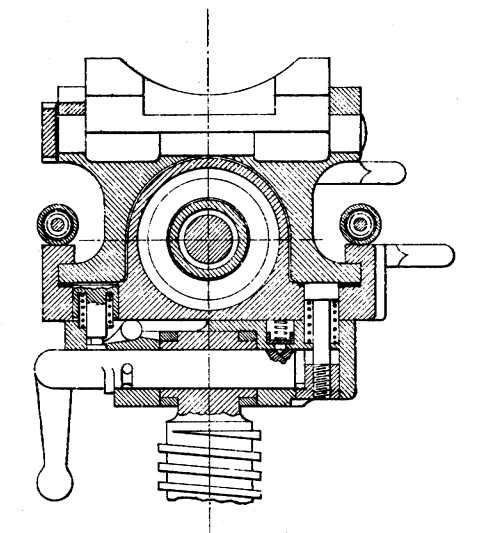

Sezione verticale sulla linea C C

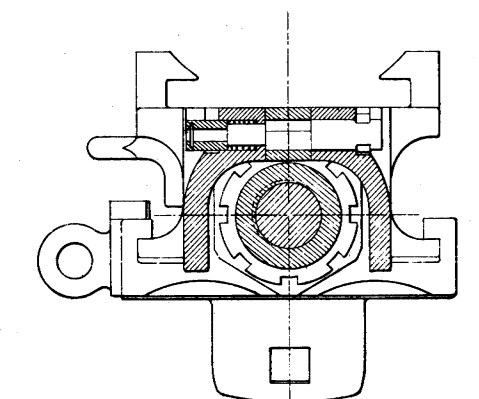

Proiezione della testata posteriore

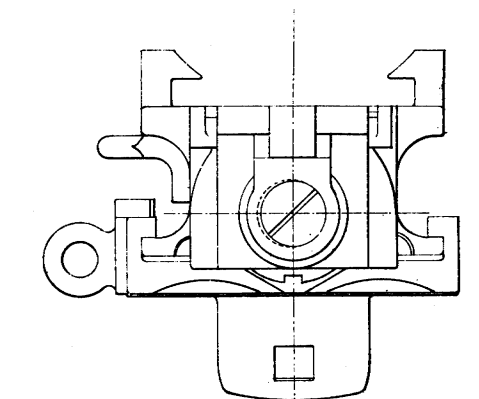

ANTEPRIMA RIDOTTA  
PAGINE MANCANTI  
TALPO.IT  
TALPO.IT



AFFUSTO PER CANNONE DA 65-FRENO A CULLA E SLITTA

Scala 1/4

